

404623-1

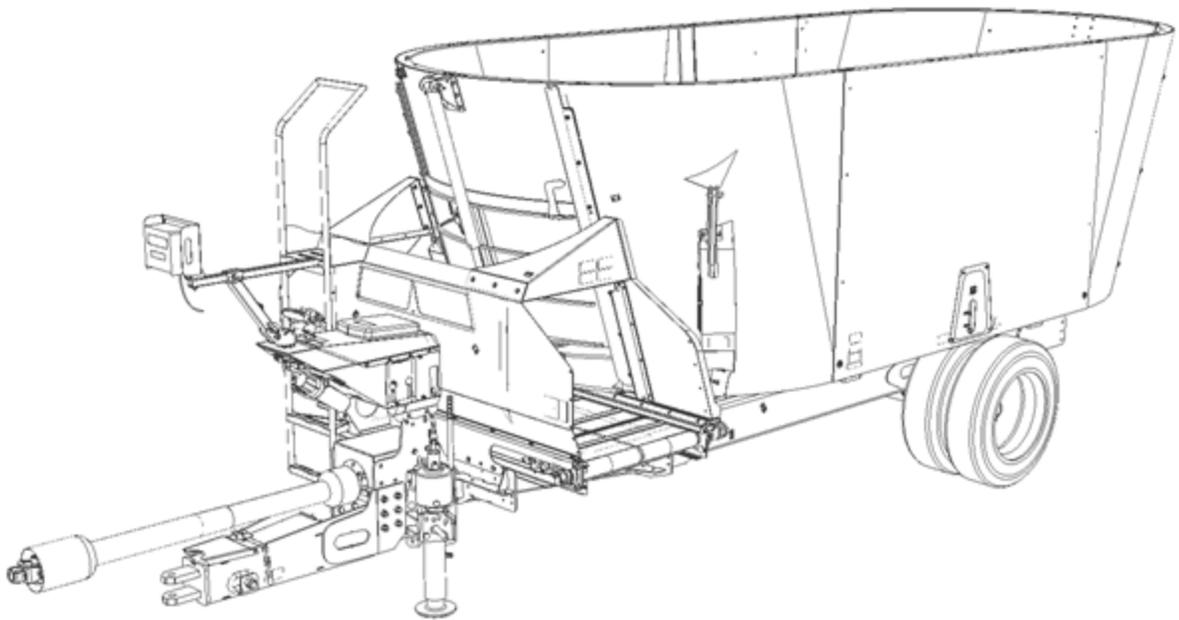

Mobile Mixer
SMARTMIX



User Guide

TRANSLATION OF THE ORIGINAL INSTRUCTIONS – 2022

Table of contents

How to reach us	5
Starting guidelines	7
Anderson limited warranty	9
About this manual	11
1 Introduction	13
1.1 Overview	13
1.2 Technical specifications	15
1.3 Optional parts	39
1.4 Machine identification	40
1.5 Safety and operating pictograms	41
2 Safety precautions	47
2.1 Basic safety guidelines	47
2.2 Safety tips for transport	50
2.3 Safety tips for hitching	52
2.4 Safety tips for maintenance and repairs	53
2.5 Safety tips for the PTO and drive shaft	55
2.6 Waste recovery	56
3 Getting started	57
3.1 Hitching to the tractor	57
3.2 Connecting the hydraulic and electrical systems	59
3.3 Connecting the drive shaft	61
3.4 Unhitching	64
3.5 Testing the rotating parts	65
4 Adjustments	69
4.1 Adjusting the hitch position	69
4.2 Adjusting the jack height	70
4.3 Adjusting the cut size	72
4.4 Adjusting the hatch openings	74
4.5 Adjusting the horizontal conveyor offset	75
4.6 Adjusting the conveyor speed	78



ANDERSON

4.7	Adjusting the articulated support for the DG500 scale system	79
4.8	Adjusting the angle of the inclined conveyor (option)	80
4.9	Adjusting the auger knives	81
4.10	Adjusting the hay retention ring	81
5	Operation	83
5.1	Controls	83
5.2	Loading and mixing	84
5.3	Weighing	86
5.4	Distribution	86
5.5	Cleaning the magnetic extractor	86
5.6	Using the tridem axle	87
6	Troubleshooting	89
6.1	Common problems	89
6.2	Common problems with the control system	93
6.3	Replacing the shear bolts	94
7	Maintenance	103
7.1	Maintenance schedule	104
7.2	Greasing	108
7.3	Checking the tires	114
7.4	Checking the planetary oil level and changing the oil	115
7.5	Checking the gearbox oil level and changing the oil	118
7.6	Performing maintenance on the planetary oil tank cap	120
7.7	Sharpening or replacing the knives	120
7.8	Adjusting or replacing the auger scrapers	121
7.9	Checking and adjusting the conveyor tension	123
7.10	Checking and adjusting the scrapers	126
7.11	Maintaining the jacks	127
7.12	Tightening torque	128
7.13	Cleaning	130
7.14	Storage	131
	Appendix A — SMARTMIX maintenance summary tables	132



How to reach us

When contacting us, please have the following information ready:

- The product model and serial number;
- Your name, address and phone number;
- The purchase date and invoice number;
- The dealer's name, address and phone number and the sales representative's name;
- A detailed description of your problem.

Please always call your representative first. If your representative is absent or helping another customer, our support team can provide immediate assistance. The Anderson service department works in partnership with your dealer. Together, we will ensure any problems you encounter are resolved quickly and efficiently.

You can reach our service department at:

Address: ANDERSON GROUP

5125 De la Plaisance St.
Chesterville, QC G0P 1J0
CANADA

Phone: 1-819-382-2952

Fax: 1-819-382-2218

Email: support@grpanderson.com

Website: grpanderson.com

Starting guidelines

Before starting your Anderson equipment, we strongly recommend that you:

- Carefully read and understand the contents of this guide
- Follow all the safety guidelines
- Follow the start-up procedures

NOTE: This manual contains important information about equipment maintenance and use. Please give it to the new owner when selling or transferring the machine.

Anderson limited warranty

- The one-year warranty begins on the date that the new equipment is sold to the customer.
- If during the year following the purchase of new equipment, your Anderson equipment fails to function properly due to defective design, materials, manufacturing or assembly, our company will repair your equipment free of charge.
- Keep your original invoice or a photocopy. Please refer to your invoice when ordering parts or inquiring about your equipment's operating procedures or your warranty.
- An authorized Anderson dealer must replace and/or repair equipment parts. This only applies to parts and labour. All work must be preauthorized by the Anderson customer service department.
- The customer will be responsible for transporting the equipment to/from the authorized dealer.
- The dealer will describe the terms of this warranty to the customer before the retail sale and will record the date of purchase, serial number and equipment description.
- To have equipment repaired under warranty, the customer must advise the dealer of the problem as soon as possible and request that the repairs be made according to the terms of the applicable warranty.
- Given that we are always seeking to improve our products, our company reserves the right to modify our equipments, their characteristics and their parts at any time without prior notice or obligation.
- In no event will Anderson be liable for any incidental or consequential damages or injuries, including but not limited to loss of profits, rental of substitute equipment, or other commercial or personal loss or damages arising as a result of a fundamental breach or breach of a fundamental term.

Notwithstanding the foregoing:

Warranty policies, procedures and provisions summary

Purpose of warranty

The fundamental responsibility of the warranty is to correct defects in material and workmanship of the products sold by Groupe Anderson (hereafter called "Anderson" or "Anderson Group"). This outline is intended to help you understand Anderson's warranty policies and ensure that you receive the best service possible for your Anderson equipment.

- The warranty is limited to 1 year (12 months). This specified period begins on the date the new equipment is sold to the customer.



ANDERSON

- The warranty is non-transferable in the event of resale unless the resale is through an authorized Anderson dealer.

Warranty exemptions

- Your warranty may be voided if Anderson determines that the equipment has been subjected to bad treatment or negligence, inappropriate use, insufficient maintenance, improper protection during storage or damage due to vandalism, bad weather, natural elements, collision or an accident.
- The warranty is void if your equipment has been modified in any way without Anderson's express authorization.
- The warranty does not cover towing expenses or service calls.
- No warranty is extended to regular service items such as fluids, paint and tires.
- Certain parts, such as the Honda engine and battery, are covered under warranties from their respective manufacturers. Details on these warranties can be obtained from your dealer.
- Warranty does not cover damage caused by harsh weather conditions or unstable ground conditions. Such as frozen parts on the equipment or performance issues on inadequate terrain.
- No warranty is issued for performance issues, such as downtime and capacity issues.

No dealer warranty

- Except for conditions or warranties that may not be excluded by law, the selling dealer makes no warranty of its own on any item warranted by Anderson unless it delivers to the purchaser a separate written warranty document specifically warranting the item. The selling dealer has no authority to make any representation or promise on behalf of Anderson or to modify the terms or limitations of this warranty in any way.

Anderson's responsibilities

- In the event that parts must be shipped from Anderson, freight will be paid by Anderson and will be shipped by the most economical means to arrive in the shortest possible time. Air, Next Day Air, Priority and other special shipment methods requested by the dealer will be at the customer's expense.

About this manual

This technical manual will teach you how to set up, maintain and safely operate your mixer.

This guide covers all SMARTMIX mixer models. Ensure that you consult the sections that apply to your machine.

Disclaimer

The illustrations and information in this manual are accurate as of printing. Anderson Group reserves the right to modify its machines without prior notice.

Conventions



“Danger!” messages identify information that should be read to prevent serious or fatal injuries to people and animals.



“Warning!” messages identify information that should be read to prevent minor injuries to people and animals or damage to the machine.

NOTE: Notes provide additional information about the section content.

1 Introduction

Congratulations! You have just purchased an Anderson SMARTMIX mixer, which is a quality piece of machinery specially designed for feeding herds.

The mixer:

- Stores silage, supplements and all types of bales;
- Mixes, and if necessary, cuts these different products;
- Transports the loaded products to the distribution area;
- Distributes the loaded products.

1.1 Overview

The following figures show the main components of SMARTMIX mixers.

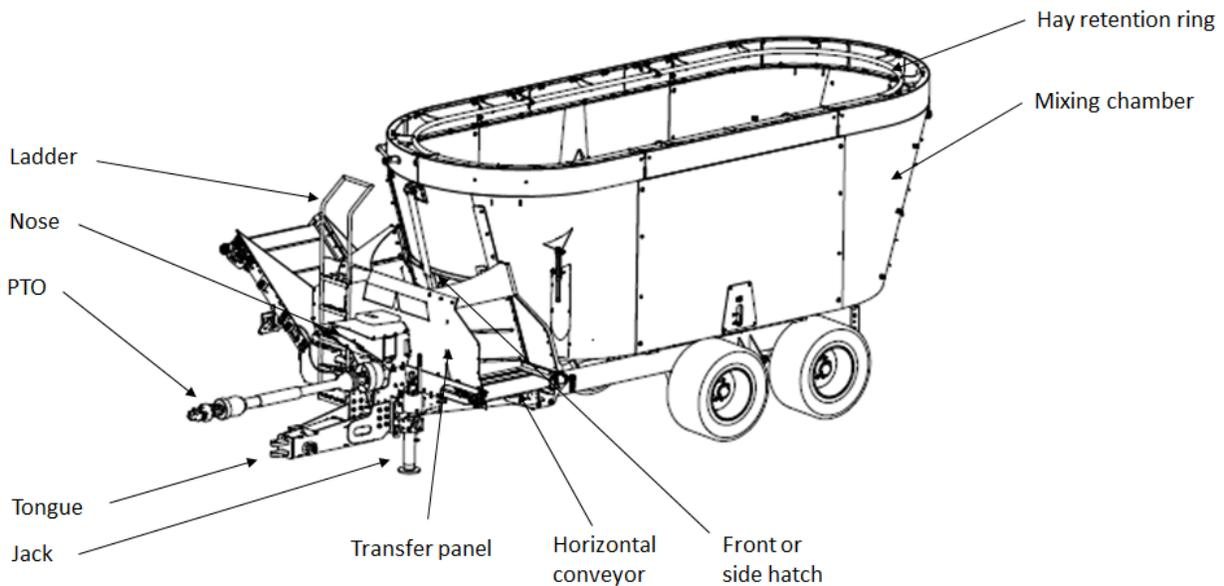

Figure 1 — Main Components of the SMARTMIX Mixer

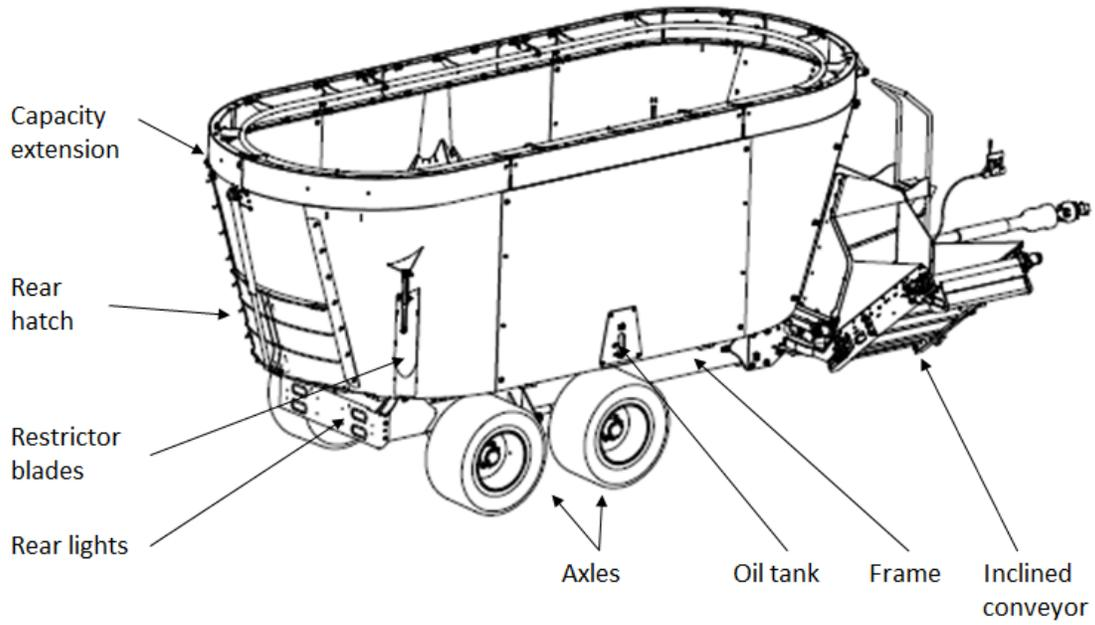

Figure 2 — Main Components of the SMARTMIX Mixer (continued)

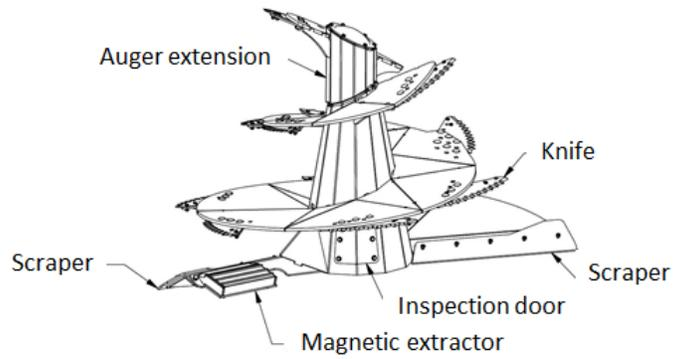

Figure 3 — SMARTMIX Auger

1.2 Technical specifications

NOTE: SMARTMIX ST models are equipped with a side hatch, and SMARTMIX FD models are equipped with a front horizontal conveyor.



ANDERSON

1.2.1 SMARTMIX ST

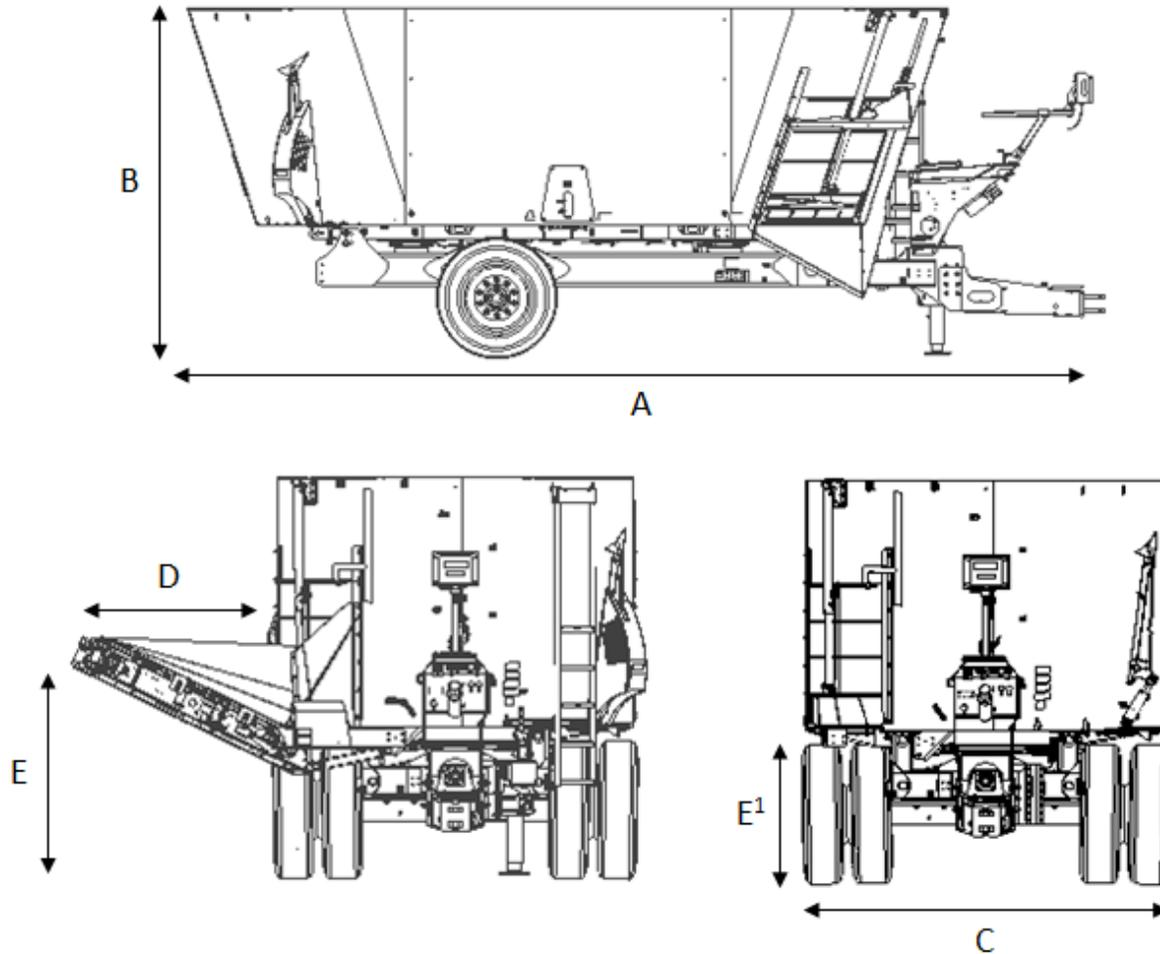

Figure 4 — Dimensions: SMARTMIX ST

Table 1 — Dimensions: SMARTMIX ST

		A280ST	A380ST	A450ST	A520ST	A700ST	A920ST
Length (A)		4.46 m (176 in.)	4.79 m (189 in.)	4.84 m (190 in.)	6.15 m (242 in.)	7.32 m (288 in.)	7.44 m (293 in.)
Height (B)	No capacity extension	2.49 m (98 in.)	2.69 m (106 in.)	2.84 m (112 in.)	2.59 m (102 in.)	2.79 m (110 in.)	3.1 m (122 in.)
	15 cm (6 in.) capacity extension	2.64 m (104 in.)	2.84 m (112 in.)	3 m (118 in.)	2.74 m (108 in.)	2.95 m (116 in.)	3.25 m (128 in.)
	30 cm (12 in.) capacity extension	2.79 m (110 in.)	3 m (118 in.)	3.15 m (124 in.)	2.9 m (114 in.)	3.07 m (121 in.)	3.4 m (134 in.)
	45 cm (18 in.) capacity extension	2.95 m (116 in.)	3.15 m (124 in.)	3.3 m (130 in.)	3.05 m (120 in.)	3.25 m (128 in.)	3.56 m (140 in.)
Hay retention ring (additional height)		0 cm/9 cm (0 in./3.5 in.)					
Width (C) Note: Regulations prohibit equipment that is more than 260 cm (102 in.) wide from travelling on the road.	Without inclined conveyor	2.29 m (90 in.)	2.57 m (101 in.)	2.84 m (112 in.)	2.57 m (101 in.)	2.57 m (101 in.)	2.87 m (113 in.)
	With inclined conveyor	2.69 m (106 in.)	2.97 m (117 in.)	3.18 m (125 in.)	2.92 m (115 in.)	2.97 m (117 in.)	3.2 m (126 in.)
Operating angle of the inclined conveyor (in degrees)		26 @ 39	26 @ 39	23 @ 39	23 @ 39	26 @ 39	23 @ 39



ANDERSON

		A280ST	A380ST	A450ST	A520ST	A700ST	A920ST
Overall width at wheels		2.18 m (86 in.)	2.18 m (86 in.)	2.18 m (86 in.)	2.51 m (99 in.)	2.54 m (100 in.)	2.54 m (100 in.)
Distance from distribution point (D)	0.9 m (3 ft.) inclined conveyor min. angle	0.73 m (29 in.)	0.58 m (23 in.)	0.41 m (16 in.)	0.57 m (22 in.)	0.58 m (23 in.)	0.41 m (16 in.)
	1.2 m (4 ft.) inclined conveyor min. angle	0.95 m (38 in.)	0.8 m (32 in.)	0.64 m (25 in.)	0.8 m (31 in.)	0.8 m (32 in.)	0.64 m (25 in.)
	1.5 m (5 ft.) inclined conveyor min. angle	1.32 m (52 in.)	1.17 m (46 in.)	1.01 m (40 in.)	1.17 m (46 in.)	1.17 m (46 in.)	1.01 m (40 in.)
	1.8 m (6 ft.) inclined conveyor min. angle	1.54 m (61 in.)	1.39 m (55 in.)	1.24 m (49 in.)	1.4 m (55 in.)	1.39 m (55 in.)	1.24 m (49 in.)
	2.1 m (7 ft.) inclined conveyor min. angle	1.91 m (75 in.)	1.75 m (69 in.)	1.62 m (64 in.)	1.78 m (70 in.)	1.75 m (69 in.)	1.62 m (64 in.)
	2.4 m (8 ft.) inclined conveyor min. angle	2.14 m (84 in.)	1.98 m (78 in.)	1.84 m (73 in.)	2.01 m (79 in.)	1.98 m (78 in.)	1.84 m (73 in.)
	0.9 m (3 ft.) inclined conveyor max. angle	0.66 m (26 in.)	0.51 m (20 in.)	0.33 m (13 in.)	0.51 m (20 in.)	0.51 m (20 in.)	0.33 m (13 in.)

		A280ST	A380ST	A450ST	A520ST	A700ST	A920ST
	1.2 m (4 ft.) inclined conveyor max. angle	0.85 m (33 in.)	0.7 m (28 in.)	0.52 m (21 in.)	0.7 m (28 in.)	0.7 m (28 in.)	0.52 m (21 in.)
	1.5 m (5 ft.) inclined conveyor max. angle	1.16 m (46 in.)	1.02 m (40 in.)	0.84 m (33 in.)	1.02 m (40 in.)	1.01 m (40 in.)	0.84 m (33 in.)
	1.8 m (6 ft.) inclined conveyor max. angle	1.36 m (53 in.)	1.21 m (48 in.)	1.01 m (40 in.)	1.21 m (48 in.)	1.2 m (47 in.)	1.03 m (40 in.)
	2.1 m (7 ft.) inclined conveyor max. angle	1.67 m (66 in.)	1.52 m (60 in.)	1.34 m (53 in.)	1.52 m (60 in.)	1.52 m (60 in.)	1.34 m (53 in.)
	2.4 m (8 ft.) inclined conveyor max. angle	1.86 m (73 in.)	1.71 m (67 in.)	1.53 m (60 in.)	1.72 m (68 in.)	1.71 m (67 in.)	1.53 m (60 in.)
Distribution height (E)	Bottom of the ST mixing chamber (E ¹)/ FD conveyor (E ²) to the ground	0.77 m (30 in.)	0.91 m (36 in.)	0.91 m (36 in.)	0.85 m (34 in.)	1.12 m (44 in.)	1.08 m (42 in.)
	Optional 0.9 m (3 ft.) inclined conveyor min. angle (E ³)	0.9 m (36 in.)	1.05 m (41 in.)	1.02 m (40 in.)	0.96 m (38 in.)	1.25 m (49 in.)	1.18 m (47 in.)



ANDERSON

		A280ST	A380ST	A450ST	A520ST	A700ST	A920ST
	Optional 1.2 m (4 ft.) inclined conveyor min. angle (E ³)	1.01 m (40 in.)	1.15 m (45 in.)	1.11 m (44 in.)	1.06 m (42 in.)	1.36 m (54 in.)	1.28 m (50 in.)
	Optional 1.5 m (5 ft.) inclined conveyor min. angle (E ³)	1.19 m (47 in.)	1.33 m (52 in.)	1.27 m (50 in.)	1.21 m (48 in.)	1.54 m (61 in.)	1.44 m (57 in.)
	Optional 1.8 m (6 ft.) inclined conveyor min. angle (E ³)	1.3 m (51 in.)	1.44 m (57 in.)	1.37 m (54 in.)	1.31 m (52 in.)	1.65 m (65 in.)	1.54 m (61 in.)
	Optional 2.1 m (7 ft.) inclined conveyor min. angle (E ³)	1.48 m (58 in.)	1.62 m (64 in.)	1.53 m (60 in.)	1.47 m (58 in.)	1.83 m (72 in.)	1.7 m (67 in.)
	Optional 2.4 m (8 ft.) inclined conveyor min. angle (E ³)	1.59 m (63 in.)	1.73 m (68 in.)	1.63 m (64 in.)	1.57 m (62 in.)	1.94 m (76 in.)	1.79 m (71 in.)
	Optional 0.9 m (3 ft.) inclined conveyor max. angle(E ³)	1.04 m (41 in.)	1.18 m (46 in.)	1.18 m (46 in.)	1.13 m (44 in.)	1.38 m (54 in.)	1.34 m (53 in.)

	A280ST	A380ST	A450ST	A520ST	A700ST	A920ST
Optional 1.2 m (4 ft.) inclined conveyor max. angle(E ³)	1.2 m (47 in.)	1.33 m (52 in.)	1.33 m (53 in.)	1.29 m (51 in.)	1.54 m (61 in.)	1.5 m (59 in.)
Optional 1.5 m (5 ft.) inclined conveyor max. angle(E ³)	1.46 m (57 in.)	1.59 m (63 in.)	1.59 m (63 in.)	1.54 m (61 in.)	1.8 m (71 in.)	1.76 m (69 in.)
Optional 1.8 m (6 ft.) inclined conveyor max. angle(E ³)	1.61 m (64 in.)	1.75 m (69 in.)	1.75 m (69 in.)	1.7 m (67 in.)	1.96 m (77 in.)	1.92 m (76 in.)
Optional 2.1 m (7 ft.) inclined conveyor max. angle(E ³)	1.87 m (74 in.)	2.01 m (79 in.)	2.01 m (79 in.)	1.96 m (77 in.)	2.21 m (87 in.)	2.18 m (86 in.)
Optional 2.4 m (8 ft.) inclined conveyor max. angle(E ³)	2.03 m (80 in.)	2.17 m (85 in.)	2.17 m (85 in.)	2.12 m (84 in.)	2.37 m (93 in.)	2.33 m (92 in.)



ANDERSON

Table 2 — General Specifications: SMARTMIX ST

		A280ST	A380ST	A450ST	A520ST	A700ST	A920ST
Mixing chamber capacity	No capacity extension	7.9 m ³ (280 ft. ³)	10.8 m ³ (380 ft. ³)	12.8 m ³ (450 ft. ³)	14.7 m ³ (520 ft. ³)	19.8 m ³ (700 ft. ³)	26.1 m ³ (920 ft. ³)
	Optional 15 cm (6 in.) capacity extension	9 m ³ (316 ft. ³)	11.9 m ³ (420 ft. ³)	14.2 m ³ (500 ft. ³)	16.3 m ³ (574 ft. ³)	21.8 m ³ (770 ft. ³)	28.5 m ³ (1,004 ft. ³)
	Optional 30 cm (12 in.) capacity extension	10 m ³ (352 ft. ³)	13 m ³ (460 ft. ³)	15.6 m ³ (550 ft. ³)	17.8 m ³ (628 ft. ³)	23.8 m ³ (840 ft. ³)	30.8 m ³ (1,088 ft. ³)
	Optional 45 cm (18 in.) capacity extension	11 m ³ (388 ft. ³)	14.2 m ³ (500 ft. ³)	17 m ³ (600 ft. ³)	19.3 m ³ (682 ft. ³)	25.8 m ³ (910 ft. ³)	33.2 m ³ (1,172 ft. ³)
Number of mixing augers		1	1	1	2	2	2
PTO	Standard	540 rpm 1 3/8 in. Z6	540 rpm 1 3/8 in. Z6	540 rpm 1 3/8 in. Z6	540 rpm 1 3/8 in. Z6	1,000 rpm 1 3/8 in. Z21	1,000 rpm 1 3/8 in. Z21
	Optional	N/A	1,000 rpm 1 3/8 in. Z21	1,000 rpm 1 3/8 in. Z21	1,000 rpm 1 3/8 in. Z21	1,000 rpm 1 3/4 in. Z20 540 rpm 1 3/8 in. Z6	1,000 rpm 1 3/4 in. Z20
Two-speed gearbox		N/A	Optional	Optional	Optional	Optional	Optional

		A280ST	A380ST	A450ST	A520ST	A700ST	A920ST
Two-speed, three-speed and ratio gearboxes		N/A	D732, 1;1.5 540 rpm	D732, 1;1.5 540 rpm	C3A-R, 1;1.5 540 rpm C3A-R, 1.8;2.7 1,000 rpm	C3A-R, 1;1.5	C3A-R, 1;1.5
Minimum power take-off (PTO) power (hp)	Low speed	N/A	50	60	80	100	90
	High speed	60	75	85	120	150	150
Auger rotation speed	Low speed	N/A	27 rpm	27 rpm	27 rpm	27 rpm	22 rpm
	High speed	41 rpm	41 rpm	41 rpm	41 rpm	41 rpm	33 rpm
Standard planetary and transmission ratio		1,602@13.4	1,602@13.4	1,602@13.4	1,602@13.4	1,603@25.89	2,103@29.9
Optional planetary		N/A	N/A	N/A	N/A	2,103 @29.9	3,002 @30.24
Thickness of the bottom of the mixing chamber (AR235 grade)		5/8 in.	3/4 in.	3/4 in.	5/8 in.	3/4 in.	3/4 in.
Thickness of the sides of the mixing chamber (AR235 grade)		1/4 in.					
Thickness of the auger blades (AR235 grade)		5/8 in.					



ANDERSON

	A280ST	A380ST	A450ST	A520ST	A700ST	A920ST	
Number of knives	6	6	8	6	6	8	
Protection of transmission components	Shear bolt						
Required hydraulic flow	37–56 Lpm (10–15 US gpm)						
Required hydraulic pressure	160–200 bar (2,300–2,900 psi)						
Number of load cells	3	3	3	3	4	4	
Scale system	DG500 (standard)						
Empty weight on hitch — Basic configuration	1,070 kg (2,359 lb.)	634 kg (1,398 lb.)	657 kg (1,448 lb.)	366 kg (808 lb.)	981 kg (2,163 lb.)	971 kg (2,141 lb.)	
Total empty weight — Basic configuration	3,205 kg (7,067 lb.)	3,839 kg (8,465 lb.)	3,975 kg (8,765 lb.)	5,326 kg (11,744 lb.)	7,250 kg (15,987 lb.)	7,705 kg (16,987 lb.)	
Useful load capacity	3,683 kg (8,120 lb.)	4,998 kg (11,020 lb.)	5,918 kg (13,050 lb.)	6,839 kg (15,080 lb.)	9,206 kg (20,300 lb.)	12,100 kg (26,680 lb.)	
Gross weight (with load) — Basic configuration	6,888 kg (15,187 lb.)	8,837 kg (19,485 lb.)	9,893 kg (21,815 lb.)	12,165 kg (26,824 lb.)	16,457 kg (36,287 lb.)	19,807 kg (43,667 lb.)	
Maximum speed	40 km/h (25 mph)						
Axle	Standard	Single	Single	Single	Single	Single	Tandem
	Optional	N/A	N/A	N/A	N/A	Tandem	N/A
Tires	Standard	15.0/55-17 26 PLY	15.0/55-17 26 PLY	15.0/55-17 26 PLY	385/65R22.5- 20	275/70R22.5 (DOUBLE)	445/45R19.5
	Optional	N/A	N/A	N/A	N/A	445/45R19.5	N/A

	A280ST	A380ST	A450ST	A520ST	A700ST	A920ST
Tire pressure	7.1 bar (103 psi)	7.1 bar (103 psi)	7.1 bar (103 psi)	9 bar (130 psi)	9 bar (130 psi)	9 bar (130 psi)



ANDERSON

1.2.2 SMARTMIX FD

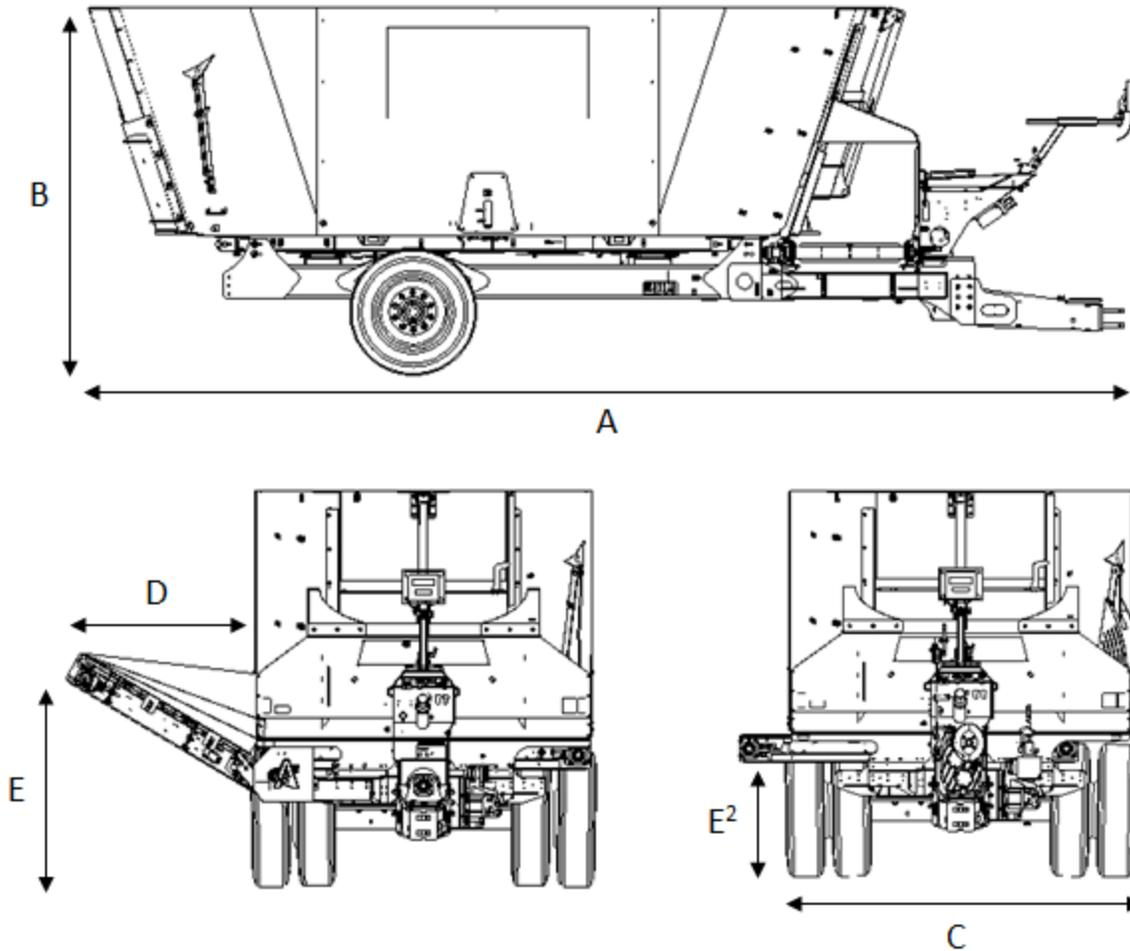

Figure 5 — Dimensions: SMARTMIX FD

Table 3 — Dimensions: SMARTMIX FD

		A380FD	A450FD	A520FD	A700FD	A920FD	A950FD	A1230FD
Length (A)		5.51 m (217 in.)	5.57 m (219 in.)	6.86 m (270 in.)	7.86 m (309 in.)	7.98 m (314 in.)	9.77 m (385 in.)	10.91 m (430 in.)
Height (B)	No capacity extension	2.69 m (106 in.)	2.84 m (112 in.)	2.59 m (102 in.)	2.79 m (110 in.)	3.1 m (122 in.)	2.97 m (117 in.)	2.97 m (117 in.)
	Optional 15 cm (6 in.) capacity extension	2.84 m (112 in.)	3 m (118 in.)	2.74 m (108 in.)	2.95 m (116 in.)	3.25 m (128 in.)	3.12 m (123 in.)	3.12 m (123 in.)
	Optional 30 cm (12 in.) capacity extension	3 m (118 in.)	3.15 m (124 in.)	2.9 m (114 in.)	3.07 m (121 in.)	3.4 m (134 in.)	3.28 m (129 in.)	3.28 m (129 in.)
	Optional 45 cm (18 in.) capacity extension	3.15 m (124 in.)	3.3 m (130 in.)	3.05 m (120 in.)	3.25 m (128 in.)	3.56 m (140 in.)	3.43 m (135 in.)	3.43 m (135 in.)
Hay retention ring (additional height)		0 cm/9 cm (0 in./3.5 in.)						



ANDERSON

		A380FD	A450FD	A520FD	A700FD	A920FD	A950FD	A1230FD
Width (C) Note: Regulations prohibit equipment that is more than 260 cm (102 in.) wide from travelling on the road.	Without inclined conveyor	2.57 m (101 in.)	2.84 m (112 in.)	2.57 m (101 in.)	2.57 m (101 in.)	2.87 m (113 in.)	2.57 m (101 in.)	2.84 m (112 in.)
	With inclined conveyor	2.97 m (117 in.)	3.15 m (124 in.)	2.97 m (117 in.)	2.97 m (117 in.)	3.18 m (125 in.)	2.97 m (117 in.)	3.15 m (124 in.)
Operating angle of the inclined conveyor (in degrees)		26 @ 39						
Overall width at wheels		2.18 m (86 in.)	2.18 m (86 in.)	2.51 m (99 in.)	2.54 m (100 in.)	2.54 m (100 in.)	2.57 m (101 in.)	2.57 m (101 in.)
Distance from distribution point (D)	0.9 m (3 ft.) inclined conveyor min. angle	0.7 m (28 in.)	0.52 m (21 in.)	0.7 m (28 in.)	0.7 m (28 in.)	0.52 m (21 in.)	0.7 m (28 in.)	0.52 m (21 in.)
	1.2 m (4 ft.) inclined conveyor min. angle	0.93 m (36 in.)	0.75 m (29 in.)	0.93 m (36 in.)	0.93 m (36 in.)	0.75 m (29 in.)	0.93 m (36 in.)	0.75 m (29 in.)

	A380FD	A450FD	A520FD	A700FD	A920FD	A950FD	A1230FD
1.5 m (5 ft.) inclined conveyor min. angle	1.29 m (51 in.)	1.12 m (44 in.)	1.29 m (51 in.)	1.29 m (51 in.)	1.12 m (44 in.)	1.29 m (51 in.)	1.12 m (44 in.)
1.8 m (6 ft.) inclined conveyor min. angle	1.52 m (60 in.)	1.34 m (53 in.)	1.52 m (60 in.)	1.52 m (60 in.)	1.34 m (53 in.)	1.52 m (60 in.)	1.34 m (53 in.)
2.1 m (7 ft.) inclined conveyor min. angle	1.89 m (74 in.)	1.71 m (67 in.)	1.89 m (74 in.)	1.89 m (74 in.)	1.71 m (67 in.)	1.89 m (74 in.)	1.71 m (67 in.)
2.4 m (8 ft.) inclined conveyor min. angle	2.11 m (83 in.)	1.93 m (76 in.)	2.11 m (83 in.)	2.11 m (83 in.)	1.93 m (76 in.)	2.11 m (83 in.)	1.93 m (76 in.)
0.9 m (3 ft.) inclined conveyor max. angle	0.63 m (25 in.)	0.45 m (18 in.)	0.63 m (25 in.)	0.63 m (25 in.)	0.45 m (18 in.)	0.63 m (25 in.)	0.45 m (18 in.)
1.2 m (4 ft.) inclined conveyor max. angle	0.82 m (32 in.)	0.64 m (25 in.)	0.82 m (32 in.)	0.82 m (32 in.)	0.64 m (25 in.)	0.82 m (32 in.)	0.64 m (25 in.)



ANDERSON

		A380FD	A450FD	A520FD	A700FD	A920FD	A950FD	A1230FD
Distribution height (E)	1.5 m (5 ft.) inclined conveyor max. angle	1.13 m (45 in.)	0.95 m (38 in.)	1.13 m (45 in.)	1.13 m (45 in.)	0.95 m (38 in.)	1.13 m (45 in.)	0.95 m (38 in.)
	1.8 m (6 ft.) inclined conveyor max. angle	1.32 m (52 in.)	1.15 m (45 in.)	1.32 m (52 in.)	1.32 m (52 in.)	1.15 m (45 in.)	1.32 m (52 in.)	1.15 m (45 in.)
	2.1 m (7 ft.) inclined conveyor max. angle	1.64 m (64 in.)	1.46 m (57 in.)	1.64 m (64 in.)	1.64 m (64 in.)	1.46 m (57 in.)	1.64 m (64 in.)	1.46 m (57 in.)
	2.4 m (8 ft.) inclined conveyor max. angle	1.83 m (72 in.)	1.65 m (65 in.)	1.83 m (72 in.)	1.83 m (72 in.)	1.65 m (65 in.)	1.83 m (72 in.)	1.65 m (65 in.)
	Bottom of the ST mixing chamber (E ¹)/ FD conveyor (E ²) to the ground	0.66 m (26 in.)	0.66 m (26 in.)	0.61 m (24 in.)	0.86 m (34 in.)	0.82 m (32 in.)	0.88 m (35 in.)	0.88 m (35 in.)

		A380FD	A450FD	A520FD	A700FD	A920FD	A950FD	A1230FD
	Optional 0.9 m (3 ft.) inclined conveyor min. angle (E ³)	0.93 m (37 in.)	0.93 m (37 in.)	0.88 m (35 in.)	1.14 m (45 in.)	1.08 m (43 in.)	1.16 m (46 in.)	1.16 m (46 in.)
	Optional 1.2 m (4 ft.) inclined conveyor min. angle (E ³)	1.04 m (41 in.)	1.04 m (41 in.)	0.99 m (39 in.)	1.24 m (49 in.)	1.19 m (47 in.)	1.26 m (50 in.)	1.26 m (50 in.)
	Optional 1.5 m (5 ft.) inclined conveyor min. angle (E ³)	1.22 m (48 in.)	1.22 m (48 in.)	1.17 m (46 in.)	1.42 m (56 in.)	1.37 m (54 in.)	1.44 m (57 in.)	1.44 m (57 in.)
	Optional 1.8 m (6 ft.) inclined conveyor min. angle (E ³)	1.33 m (52 in.)	1.33 m (52 in.)	1.27 m (50 in.)	1.53 m (60 in.)	1.48 m (58 in.)	1.55 m (61 in.)	1.55 m (61 in.)



ANDERSON

	A380FD	A450FD	A520FD	A700FD	A920FD	A950FD	A1230FD
Optional 2.1 m (7 ft.) inclined conveyor min. angle (E ³)	1.5 m (59 in.)	1.5 m (59 in.)	1.45 m (57 in.)	1.71 m (67 in.)	1.65 m (65 in.)	1.73 m (68 in.)	1.73 m (68 in.)
Optional 2.4 m (8 ft.) inclined conveyor min. angle (E ³)	1.61 m (63 in.)	1.61 m (63 in.)	1.56 m (61 in.)	1.81 m (71 in.)	1.76 m (69 in.)	1.83 m (72 in.)	1.83 m (72 in.)
Optional 0.9 m (3 ft.) inclined conveyor max. angle (E ³)	1.07 m (42 in.)	1.07 m (42 in.)	1.02 m (40 in.)	1.27 m (50 in.)	1.22 m (48 in.)	1.29 m (51 in.)	1.29 m (51 in.)
Optional 1.2 m (4 ft.) inclined conveyor max. angle (E ³)	1.23 m (48 in.)	1.23 m (48 in.)	1.18 m (46 in.)	1.43 m (56 in.)	1.38 m (54 in.)	1.45 m (57 in.)	1.45 m (57 in.)

	A380FD	A450FD	A520FD	A700FD	A920FD	A950FD	A1230FD
Optional 1.5 m (5 ft.) inclined conveyor max. angle (E ³)	1.49 m (59 in.)	1.49 m (59 in.)	1.44 m (57 in.)	1.69 m (67 in.)	1.64 m (65 in.)	1.72 m (68 in.)	1.72 m (68 in.)
Optional 1.8 m (6 ft.) inclined conveyor max. angle (E ³)	1.65 m (65 in.)	1.65 m (65 in.)	1.6 m (63 in.)	1.85 m (73 in.)	1.8 m (71 in.)	1.88 m (74 in.)	1.88 m (74 in.)
Optional 2.1 m (7 ft.) inclined conveyor max. angle (E ³)	1.91 m (75 in.)	1.91 m (75 in.)	1.86 m (73 in.)	2.12 m (83 in.)	2.06 m (81 in.)	2.14 m (84 in.)	2.14 m (84 in.)
Optional 2.4 m (8 ft.) inclined conveyor max. angle (E ³)	2.07 m (82 in.)	2.07 m (82 in.)	2.02 m (80 in.)	2.28 m (90 in.)	2.22 m (88 in.)	2.3 m (90 in.)	2.3 m (90 in.)



ANDERSON

Table 4 — General Specifications: SMARTMIX FD

		A380FD	A450FD	A520FD	A700FD	A920FD	A950FD	A1230FD
Capacity	No capacity extension	10.8 m ³ (380 ft. ³)	12.8 m ³ (450 ft. ³)	14.7 m ³ (520 ft. ³)	19.8 m ³ (700 ft. ³)	26.1 m ³ (920 ft. ³)	26.1 m ³ (920 ft. ³)	34.9 m ³ (1,230 ft. ³)
	Optional 15 cm (6 in.) capacity extension	11.9 m ³ (420 ft. ³)	14.2 m ³ (500 ft. ³)	16.3 m ³ (574 ft. ³)	21.8 m ³ (770 ft. ³)	28.5 m ³ (1,004 ft. ³)	28.8 m ³ (1,017 ft. ³)	38.1 m ³ (1,344 ft. ³)
	Optional 30 cm (12 in.) capacity extension	13.3 m ³ (460 ft. ³)	15.6 m ³ (550 ft. ³)	17.8 m ³ (628 ft. ³)	23.8 m ³ (840 ft. ³)	30.8 m ³ (1,088 ft. ³)	31.6 m ³ (1,114 ft. ³)	41.3 m ³ (1,458 ft. ³)
	Optional 45 cm (18 in.) capacity extension	14.2 m ³ (500 ft. ³)	17 m ³ (600 ft. ³)	19.3 m ³ (682 ft. ³)	25.8 m ³ (910 ft. ³)	33.2 m ³ (1,172 ft. ³)	34.3 m ³ (1,211 ft. ³)	44.5 m ³ (1,572 ft. ³)
Number of mixing augers		1	1	2	2	2	3	3

		A380FD	A450FD	A520FD	A700FD	A920FD	A950FD	A1230FD
PTO	Standard	540 rpm 1 3/8 in. Z6	540 rpm 1 3/8 in. Z6	540 rpm 1 3/8 in. Z6	1,000 rpm 1 3/8 in. Z21	1,000 rpm 1 3/8 in. Z21	1,000 rpm 1 3/8 in. Z21	1,000 rpm 1 3/4 in. Z20
	Optional	1,000 rpm 1 3/8 in. Z21	1,000 rpm 1 3/8 in. Z21	1,000 rpm 1 3/8 in. Z21	1,000 rpm 1 3/4 in. Z20 540 rpm 1 3/8 in. Z6	1,000 rpm 1 3/4 in. Z20	1,000 rpm 1 3/4 in. Z20	1,000 rpm 1 3/8 in. Z21
Two-speed gearbox		Optional	Optional	Optional	Optional	Optional	Standard	Optional
Two-speed, three-speed and ratio gearboxes		D732, 1;1.5 540 rpm	D732, 1;1.5 540 rpm	C3A-R, 1;1.5 540 rpm C3A-R, 1.8;2.7 1,000 rpm	C3A-R, 1;1.5	C3A-R, 1;1.5	A613R, 1.8;2.7 @ 2 speeds	A613R, 1;1.8 A614R, 1;1.8;3.2 @ 3 speeds
Minimum power take-off (PTO) power (hp)	Low speed	50	60	80	100	90	120	145
	High speed	75	85	120	150	150	180	210
Auger rotation speed	Low speed	27 rpm	27 rpm	27 rpm	27 rpm	22 rpm	27 rpm	18 rpm/ 10 rpm
	High speed	41 rpm	41 rpm	41 rpm	41 rpm	33 rpm	41 rpm	33 rpm
Standard planetary and ratio		1,602@13.4	1,602@13.4	1,602@13.4	1,603@25.89	2,103@29.9	2,102@13.54	3,002@30.24



ANDERSON

	A380FD	A450FD	A520FD	A700FD	A920FD	A950FD	A1230FD
Optional planetary	N/A	N/A	N/A	2,103 @29.9	3,002 @30.24	N/A	N/A
Thickness of the bottom of the mixing chamber (AR235 grade)	¾ in.	¾ in.	⅝ in.	¾ in.	¾ in.	¾ in.	¾ in.
Thickness of the sides of the mixing chamber (AR235 grade)	¼ in.	¼ in.	¼ in.	¼ in.	¼ in.	¼ in.	¼ in.
Thickness of the auger blades (AR235 grade)	⅝ in.	⅝ in.	⅝ in.	⅝ in.	⅝ in.	⅝ in.	⅝ in.
Number of knives	6/10	8/12	6/10	6/10	8/12	6/10	8/12
Protection of transmission components	Shear bolt	Shear bolt	Shear bolt	Shear bolt	Shear bolt	Shear bolt	Automatic disconnect clutch
Required hydraulic flow	37–56 Lpm (10–15 US gpm)						
Required hydraulic pressure	160–200 bar (2,300–2,900 psi)						
Number of load cells	3	3	3	4	4	6	6
Scale system	DG500 (standard)						
Empty weight on hitch — Basic configuration	836 kg (1,844 lb.)	862 kg (1,901 lb.)	671 kg (1,478 lb.)	1,341 kg (2,957 lb.)	1,354 kg (2,986 lb.)	Not available	1,586 kg (3,498 lb.)

		A380FD	A450FD	A520FD	A700FD	A920FD	A950FD	A1230FD
Total empty weight — Basic configuration		4,402 kg (9,707 lb.)	4,538 kg (10,007 lb.)	5,941 kg (13,100 lb.)	7,763 kg (17,117 lb.)	8,218 kg (18,117 lb.)	10,639 kg (23,460 lb.)	13,148 kg (28,991 lb.)
Useful load capacity		4,998 kg (11,020 lb.)	5,918 kg (13,050 lb.)	6,839 kg (15,080 lb.)	9,206 kg (20,300 lb.)	12,100 kg (26,680 lb.)	12,100 kg (26,680 lb.)	16,177 kg (35,670 lb.)
Gross weight (with load) — Basic configuration		9,400 kg (20,727 lb.)	10,457 kg (23,057 lb.)	12,780 kg (28,180 lb.)	16,969 kg (37,417 lb.)	20,320 kg (44,797 lb.)	22,739 kg (50,140 lb.)	29,325 kg (64,661 lb.)
Maximum speed		40 km/h (25 mph)						
Axle	Standard	Single	Single	Single	Single	Tandem	Tridem/ self-steering	Tandem
	Optional	N/A	N/A	N/A	Tandem	N/A	N/A	Tridem/ self-steering
Tires	Standard	15.0/55-17 26 PLY	15.0/55-17 26 PLY	385/65R22.5- 20	275/70R22.5 (DOUBLE)	445/45R19.5	445/45R19.5	275/70R22.5 (DOUBLE)
	Optional	N/A	N/A	N/A	445/45R19.5	N/A	N/A	445/45R19.5
Tire pressure		7.1 bar (103 psi)	7.1 bar (103 psi)	9 bar (130 psi)	9 bar (130 psi)	9 bar (130 psi)	9 bar (130 psi)	9 bar (130 psi)



Important!

It is prohibited to use the machine with a flow in excess of:

- **90 Lpm for direct drive machines without a conveyor**
- **55 Lpm for direct drive machines with a conveyor**

The flow rate of tractors that exceed these guidelines must be reduced. Exceeding the recommended flow rate can overheat the hydraulic system and result in damage that is not covered under the warranty.



1.3 Optional parts

The following table shows the optional parts available for your mixer.

Optional parts	A280	A380	A450	A520	A700	A920	A950	A1230
Rear hatch	X	X	X	X	X	X	X	X
Magnetic extractor	X	X	X	X	X	X	X	X
0.9 m (3 ft.) inclined conveyor	X	X	X	X	X	X	X	X
1.2 m (4 ft.) inclined conveyor	X	X	X	X	X	X	X	X
1.5 m (5 ft.) inclined conveyor	X	X	X	X	X	X	X	X
1.8 m (6 ft.) inclined conveyor	X	X	X	X	X	X	X	X
2.1 m (7 ft.) inclined conveyor	X	X	X	X	X	X	X	X
2.4 m (8 ft.) inclined conveyor	X	X	X	X	X	X	X	X
15 cm (6 in.) capacity extension	X	X	X	X	X	X	X	X
30 cm (12 in.) capacity extension	X	X	X	X	X	X	X	X
45 cm (18 in.) capacity extension	X	X	X	X	X	X	X	X
Hay retention ring	X	X	X	X	X	X	X	X
Direct drive, 540 rpm	STD	STD	STD	STD	X			
Two-speed gearbox, 540 rpm		X	X	X	X			
Direct drive, 1,000 rpm		X	X	X	STD	STD	STD	STD
Two-speed gearbox, 1,000 rpm				X	X	X	X	X



ANDERSON

Optional parts	A280	A380	A450	A520	A700	A920	A950	A1230
3.75 m (14.75 in.) offset for the horizontal conveyor ¹		X	X	X	X	X	X	X
Hydraulic restrictor blades	X	X	X	X	X	X	X	X
Cutting knives	X	X	X	X	X	X	X	X
Auger extension	X	X	X	X	X	X	X	
Rear lights	X	X	X	X	X	X	X	X
Single axles	STD	STD	STD	STD	STD			
Walking beam tandem axles					X	STD		STD
Tridem axles with tag axles							STD	X
Selector valve for one or two additional outlets	X	X	X	X	X	X	X	X
Weight distributor	X	X	X	X	X	X	X	X
Dina TEL 3 Bluetooth modem	X	X	X	X	X	X	X	X

STD: Standard on the model

¹ Option not compatible with the inclined conveyor and ST models with a side hatch.

1.4 Machine identification

A 5 cm x 10 cm (2 in. x 4 in.) nameplate is located on the right side of the mixer. It displays the following information about your equipment:

- Model
- Serial number
- Empty weight
- Gross weight (GVWR)
- Manufacturing year

NOTE: You must always have this information on hand when ordering replacement parts or requesting assistance from our customer service department.

You can record the identifying information for your equipment in Figure 6.

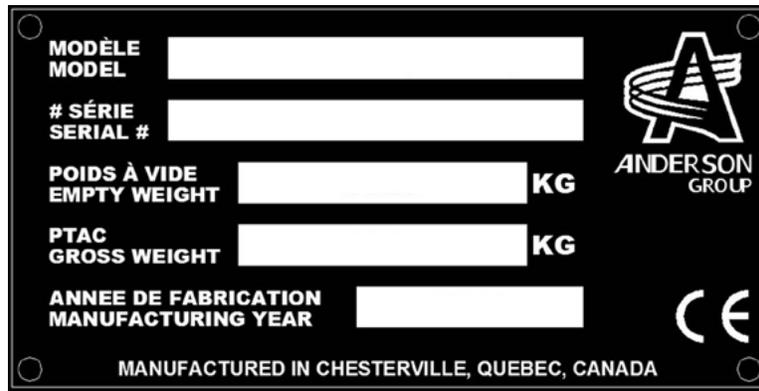

Figure 6 — Nameplate



1.5 Safety and operating pictograms

SMARTMIX mixers have numerous labels that detail the main safety and operating guidelines. Ensure that you see and understand them.

Table 5 — Safety and Operating Pictograms

Pictogram	Meaning
	<p>Warning! Carefully read and understand the contents of the user guide before using the machine.</p>

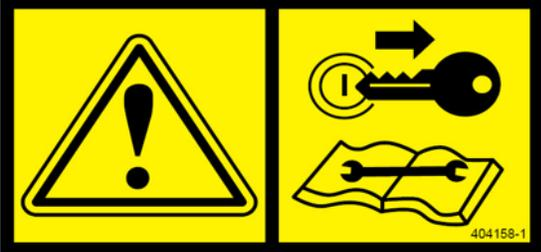
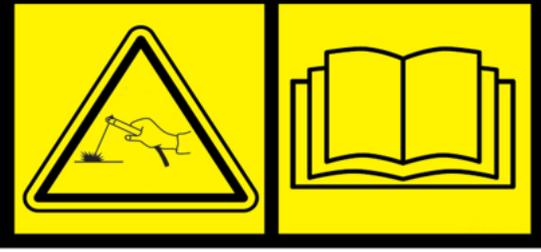

ANDERSON

Pictogram	Meaning
	<p>Warning! Before doing any maintenance or repairs, turn off the engine, remove the key, and see "Maintenance" on page 103.</p>
	<p>Risk of burns or pressurized hydraulic oil penetrating the skin.</p> <p>Consult the operator's manual.</p>
	<p>Warning! Do not do any welding directly on the equipment. This could damage the load cells.</p> <p>If necessary, ensure that the load cells are not between the part to be welded and the grounding device. Consult "Maintenance" on page 103.</p>
	<p>Warning! Risk of fingers and hands being severed.</p> <p>Keep your hands clear of the moving mixing augers.</p>

Pictogram	Meaning
 	<p>Warning! Risk of hands being crushed.</p>
	<p>Warning! Risk of getting caught in the conveyor belt. Keep clear of the conveyor when it is running.</p>
	<p>Warning! Strong magnetic field. Individuals with pacemakers must keep clear.</p>

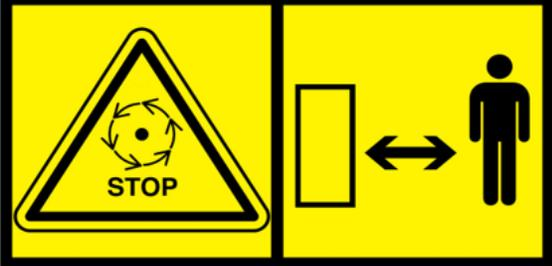

ANDERSON

Pictogram	Meaning
	<p>Warning! Rotating parts. Keep clear of the equipment.</p>
	<p>Warning! Falling bales. During work, keep clear of the machine.</p>
	<p>Warning! Consult the manual before entering the machine.</p>
	<p>Warning! Crush hazard. Ensure that the safety valve lever has been rotated 90 degrees before entering the mixing chamber.</p>

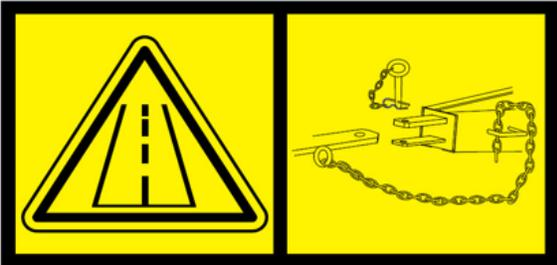
Pictogram	Meaning
	<p>Warning! Do not go underneath the inclined conveyor. It could fall.</p>
	<p>Warning! Always attach the safety chain before driving on public roads.</p>
	<p>Maximum authorized rotation speed at the equipment intake.</p>
	<p>Greasing point. Consult "Maintenance" on page 103.</p>

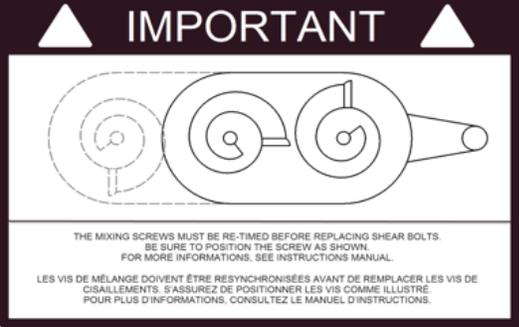
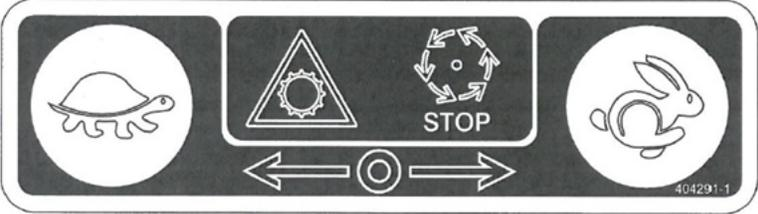

ANDERSON

Pictogram	Meaning
	<p>Oil tank. Consult "Maintenance" on page 103.</p>
	<p>Warning! Check that the wheels are tight. Consult "Maintenance" on page 103.</p>
	<p>Recommended auger position. Consult "Getting started" on page 57.</p>
	<p>Low or high speed. Warning! Stop the drive shaft before changing speeds. Consult "Getting started" on page 57.</p>

2 Safety precautions

Your Anderson machine was designed to minimize risk to the operator. Nevertheless, it must only be used for its intended purpose. Misuse of the machine may result in injury to the operator.

The machine has a hydraulic system and moving mechanical parts. All these components can cause serious or even fatal injury to people and animals. It is strongly recommended that you carefully read and follow the guidelines below.

2.1 Basic safety guidelines

2.1.1 General

- Follow the safety tips and instructions in all sections of this guide.
- Always follow the safety guidelines shown in the pictograms on your equipment.
- Remember that vigilance and caution are the best tools for staying safe.
- Maintain your equipment properly. Proper maintenance will make your equipment safer, more effective and longer lasting.
- Always leave safety devices in place. If they are removed or damaged, do not use your equipment until they have been replaced or fixed.
- When the mixer is not hitched to a tractor, make sure to properly immobilize it by putting chocks on each side of its wheels. Anderson Group does not provide chocks with the equipment.
- Wear protective clothing. Avoid scarves, jewelry, long hairstyles and loose clothing (pants, shirts or coats) that can easily get stuck in the equipment's moving parts.
- Always follow all accident prevention, safety, occupational health, environmental protection and traffic rules and regulations.
- On public roads, follow the rules of the road and obey the 40 km/h (25 mph) speed limit.
- The equipment must be operated by a single trained individual. The owner must train any trainees or other temporary external help and inform them of the safety and operating rules.
- All people, animals and obstacles must be clear of the equipment before and during operation.
- The equipment must never be used to transport people, animals or objects other than those for which it was designed.
- Never attempt to remove material from the equipment before the equipment and tractor have come to a complete stop.
- Always turn off the tractor engine before working on the equipment (greasing, adjustments, maintenance). Disconnect all power sources (transmissions, hydraulic and electrical connections).
- Before working on the equipment, ensure that it cannot be started accidentally.
- Completely shut down the equipment if you detect any unusual noises or vibrations. Locate and eliminate the cause of the noise or vibration before proceeding. Call your dealer if necessary.



ANDERSON

- Before each use, check the screws, nuts and couplings and tighten them as needed.
- Before each use and after adjustments and maintenance, ensure that all safety devices are in place, locked and in good condition.
- Do not walk on any part of the equipment, except the areas intended for this purpose.
- Ensure that all remote controls (cables, hoses, etc.) are placed in the designated areas to prevent them from accidentally being triggered and causing an accident or damage.

NOTE: Terms such as right, left, front and rear are based on a person standing behind the equipment and looking toward the front of the equipment.

2.1.2 Operator qualifications

- The machine must only be used, maintained and repaired by people who are familiar with its features and know how to operate it safely.
- Familiarize yourself with the machine before operating it. A full understanding of all the tractor controls is particularly important.

2.1.3 Surroundings

- Adjust your speed and driving style to the terrain, roads and paths. Be vigilant and cautious!
- Always drive slowly and avoid sudden changes of direction, especially on rough or steep terrain and while turning.
- Avoid suddenly braking and accelerating when going up or down a slope.
- Ideally, use your machine in daylight. Otherwise, ensure that you have adequate artificial lighting.

2.1.4 Manufacturer and user responsibilities

	Failure to comply with the following rules can make your machine dangerous. The manufacturer shall not be held liable in the event of damage or injury.
---	--

- Follow all installation, operating, adjustment, maintenance and repair instructions in this manual.
- Use only the recommended replacement parts and accessories.
- Do not modify or have another person modify your machine and its accessories (mechanical, electrical, hydraulic) without the prior written consent of the manufacturer.

2.1.5 Warnings/pictograms

- The warnings and pictograms on the machine provide safety information and help prevent accidents.
- Ensure that the warnings and pictograms remain clean and clearly visible. In the event of



damage, ask your manufacturer (or dealer) for new labels.

- During repairs, ensure that the replacement parts bear the same labels as the original parts.

2.1.6 Toxic materials

- Keep a first aid kit handy.
- Avoid contact with skin, eyes and mouth when using products such as fuels, oils, solvents and cleaning products, most of which contain harmful substances. In the event of an incident, see a physician.
- Carefully follow safety label instructions on toxic substance containers.
- Pressurized hydraulic fluid can be released with sufficient force to penetrate the skin and cause serious injury. In the event of contact, see a physician immediately.

2.1.7 Fire

- To prevent fire, keep the machine and its accessories clean and free of grass, leaves or excess grease.
- Always have a working fire extinguisher handy.
- Check with your insurance provider that using your equipment in the intended locations does not pose any risk.

2.1.8 Overhead power lines

- Ensure that the machine and its accessories have sufficient clearance at all times.
- If the machine comes in contact with a power line, immediately stop the tractor and apply the handbrake. If you can exit the tractor without touching the electrical cables, jump out without touching the machine and the ground simultaneously. Ensure that nobody touches the machine until the power lines no longer carry a current. Ask for the power line to be disconnected.



ANDERSON

2.2 Safety tips for transport



Warning!

When driving on the road, adjust your speed to the load and terrain.

Follow the rules of the road, particularly the 40 km/h speed limit.

Ensure that your machine does not exceed the maximum width allowed by the regulations, which is 260 cm (102 in.).

- Make sure that the machine has rear lights.
- Check the tire pressure (see "Checking the tires" on page 114).
- Attach the safety chain between the mixer and the tractor using the provided anchor points.
- Check that the distribution hatch(es) are closed.
- Attach the retaining bars to the transfer panels by putting two plastic cable ties through the holes in the bars (Figure 7, A).

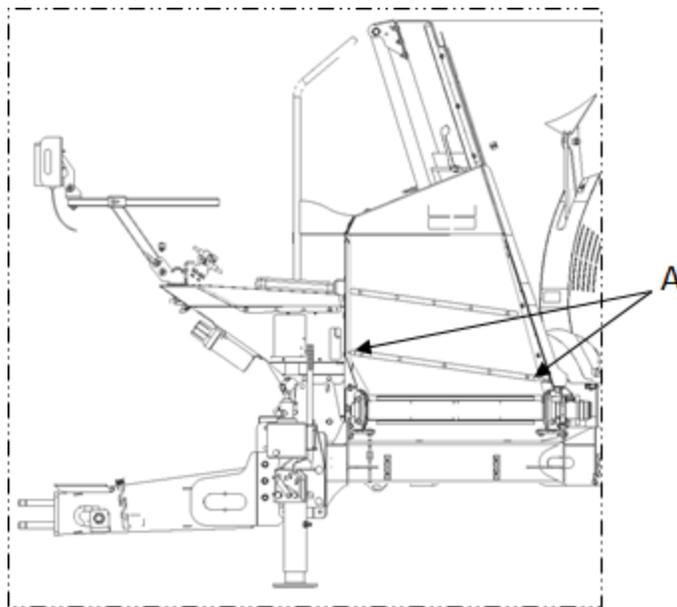

Figure 7 – Retaining Bars

- If your machine has a horizontal conveyor, check that it is centred.

- If your machine has an inclined conveyor, check that it is in transport position (Figure 8).

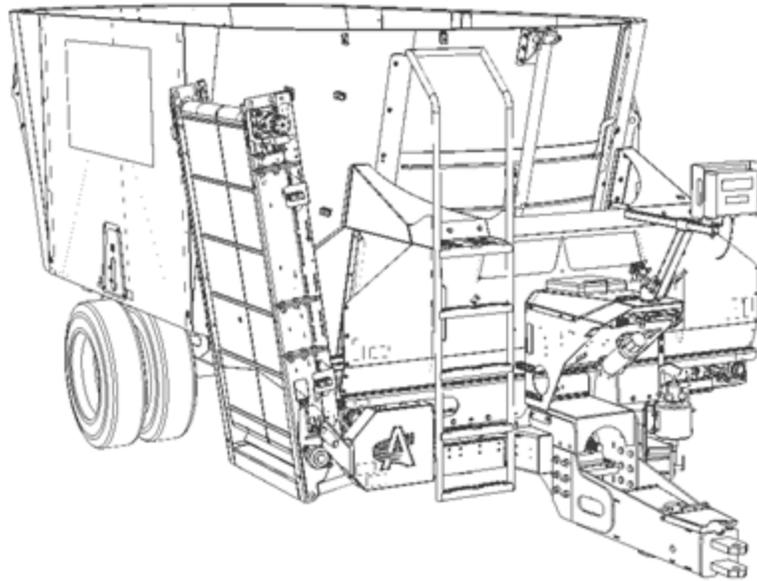

Figure 8 — Inclined Conveyor in Transport Position



If the conveyor is lowered while the machine is backing up, it reduces operator visibility and can cause collisions with people or obstacles behind the machine.



ANDERSON

2.3 Safety tips for hitching



Warning!

The hitching area involves pinching and crushing hazards.

Do not stand between the tractor and the machine during a tractor lifting procedure, regardless of whether it is controlled from inside the cab or outside the tractor.

- The equipment must be hitched to the tractor using only the intended hitch points.
- Ensure that the equipment is compatible with the tractor (minimum engine power, hitch type, tractor PTO specifications, etc.).
- Do not stand between the tractor and the equipment without first putting the gearshift in neutral, applying the parking brake on both the tractor and the equipment, and disengaging the PTO.
- When positioning the equipment, select the slowest possible speed on the tractor.
- Before hitching the equipment, ensure that the tractor lift controls are set so that the tractor cannot move during the process.
- Once the equipment is hitched, lock the coupling device. Check that the hitch is correctly locked and in good condition before moving.
- Ensure that hitching the equipment will not overload or improperly distribute weight on the tractor, which could compromise stability.
- Hitching the equipment changes the weight distribution. Do not exceed the maximum load per axle (see the tractor manufacturer's instructions).
- Do not exceed the maximum load permitted on the hitching points.
- If necessary, place ballast weights on the supports provided in accordance with the tractor manufacturer's instructions.
- When hitching the machine, install all the support and stability equipment to prevent instability.

2.4 Safety tips for maintenance and repairs

2.4.1 General



- Maintenance and repairs must be performed by qualified individuals.
- Always keep the equipment and its accessories in perfect condition.
- Keep the oil tanks clean.
- Follow the maintenance intervals.
- Before beginning work:
 - Turn off the engine and remove the key from the ignition;
 - Put the gearshift in neutral and engage the handbrake;
 - Disengage the PTO and uncouple the drive shaft from the PTO;
 - Disconnect the hydraulic supply hoses;
 - Wait for all moving parts to come to a complete stop;
 - Place the support and stabilizing devices (wedges, stand, etc.);
 - If the mixer is not hitched to a tractor, make sure to properly immobilize it by putting chocks on each side of its wheels. Anderson Group does not provide chocks with the equipment.
 - Let the gearboxes and hydraulic components cool, as well as any other parts of the machine that may be hot.

2.4.2 Welding

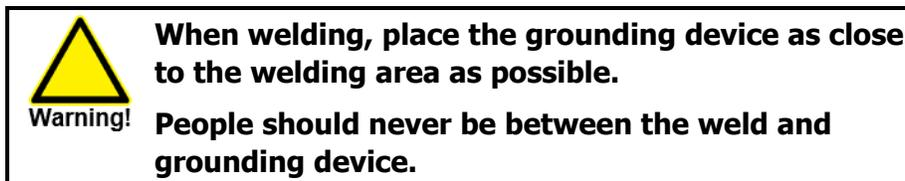

- For welding operations on the equipment or tractor, disconnect the battery or electrical power supply and protect the lines (especially rubber hoses) to prevent them from being damaged by sparks, which could cause a loss of oil, hydraulic fluid, etc.
- Move any combustible materials (hay, organic matter, gasoline, etc.) away from the area before welding.
- Eliminate any risk of fire.

2.4.3 Wiring

- Before starting work on the electrical system, disconnect the battery or electrical power supply.



ANDERSON

2.4.4 Hydraulics



A pressurized oil leak can penetrate the skin and cause serious injury. In the event of injury, see a physician immediately to prevent serious infection.

Do not use your hands to locate leaks in a hydraulic line.

- Turn off the engine and remove the key from the ignition before beginning work on the hydraulic system.
- Before working on the hydraulic system, ensure that it is not pressurized. Relieve the pressure before disconnecting the hydraulic lines.
- Before repressurizing the hydraulic lines, ensure that all the couplings are correctly tightened.
- Check the hydraulic lines regularly and replace them if they are damaged.
- The replacement lines must meet the manufacturer's technical requirements.

2.4.5 Tires

- Tire repairs must be carried out by qualified personnel equipped with the appropriate tools.
- If the air pressure is too high, the tires may explode. Use the recommended air pressure (see Table 18 — Tire Specifications in "Appendix A — SMARTMIX maintenance summary tables" on page 132).
- Ensure that the machine is immobilized, stable and protected against accidental movement before beginning work on the wheels. Use chocks and ensure that the lifting equipment has sufficient lifting capacity.

2.4.6 Repairs

- Replace worn parts with genuine parts.
- Eliminate any defects that may compromise safety.
- Immediately repair any leaks or damage to the equipment's hydraulic system.
- Do not use your fingers to search for a (pressurized) hydraulic oil leak. Instead, use an object, such as a piece of cardboard, to find the source of the leak.
- Immediately replace any damaged or defective guards or locks. Original guards affixed to the machine must not be removed or modified.
- The hoses must not come from piping used in another system.
- Immediately replace any damaged hoses.

2.4.7 Mixing chamber

Before beginning work:

- Turn off the engine and remove the key from the ignition.
- Put the gearshift in neutral and apply the handbrake.

- Disengage the PTO and uncouple the drive shaft from the PTO.
- Disconnect the hydraulic supply hoses.
- Make sure that the safety valve lever (see A) for the hydraulic hatches is in closed position (see 1) to prevent the hatches from closing accidentally.

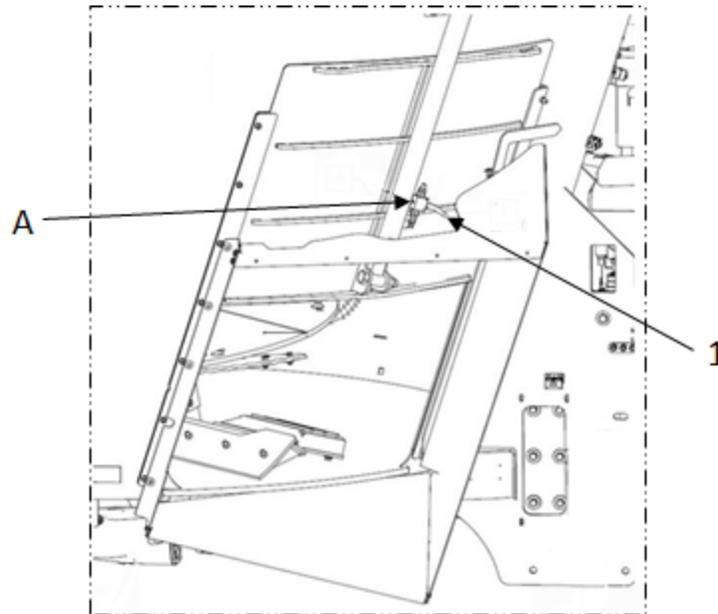

Figure 9 — Hydraulic Hatch Safety Valve

2.5 Safety tips for the PTO and drive shaft

2.5.1 Tractor PTO and machine drive shaft

- Before use, check that the speed and rotation direction of the tractor's PTO are compatible with the intended use of the machine.
- Check that the PTO guards are in place and in good condition. Immediately replace them if damaged.
- Never engage the tractor's PTO when the engine is off.
- Disengage the PTO when the angle limit of the drive shaft is likely to be reached, especially during turns, climbs and descents.
- After uncoupling it from the drive shaft, cover the tractor's PTO with its protective cap.
- Contact between the drive shaft and the tractor or machine may result in damage.

2.5.2 Drive shafts

- Only use the drive shaft supplied with the machine or recommended by the manufacturer.
- Ensure that the drive shaft tubes are properly covered when the machine is in both working and transport position.



ANDERSON

- Before coupling or uncoupling it from the drive shaft, disengage the PTO, turn off the engine and remove the key from the ignition.
- Before each use, ensure that the drive shaft is in good condition and is correctly mounted and locked.
- Check that the drive shaft guards are in place and in good condition. Immediately replace them if damaged.
- Carefully follow the safety instructions from the drive shaft manufacturer. For drive shaft maintenance, see its technical manual. The guards must be anchored to the machine and the tractor. If the shear bolt or guards are damaged, immediately replace them with genuine parts.

2.6 Waste recovery

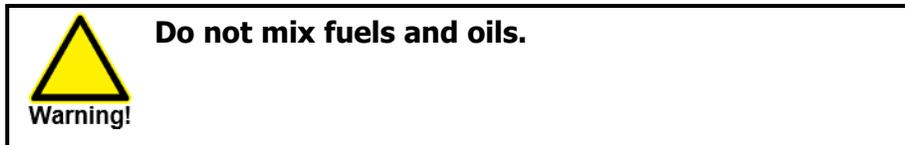

- Avoid spilling on the ground and do not empty used grease or substances such as hydraulic oil into the drain.
- Empty liquids into clean, leak-proof containers designated for this purpose. Avoid using food containers and beverage bottles.
- Return used fluids to a collection and reprocessing centre so that they are recycled or disposed of in accordance with legislation.
- Stockpiling, abandoning or dumping tires is prohibited, as is burning them outdoors. Return them to an approved distributor or collector.

3 Getting started

3.1 Hitching to the tractor

 Danger!	<p>Use extreme caution when hitching and unhitching the equipment.</p> <p>Before proceeding, securely immobilize the equipment with the devices provided.</p>
--	---

NOTE: The instructions in this manual for hitching the equipment to the tractor are provided solely for illustrative purposes.

NOTE: For better mixing, level the mixing chamber when the mixer is hitched to the tractor.

NOTE: Ensure that the tractor meets the required specifications before hitching the mixer (see "Connecting the hydraulic and electrical systems" on page 59).

To adjust the position of the mixer hitch, see "Adjusting the hitch position" on page 69.

To adjust the position of the mixer jack, see "Adjusting the jack height" on page 70.

To hitch the machine:

1. Place the tractor's drawbar so that the axis of the hitch pin hole is an appropriate distance from the end of the PTO shaft (see Table 6 and Figure 10).

Table 6 — Position of the Drawbar

PTO	Spline	Position (A)
Type 1	540 rpm – 1 3/8 in. (35 mm)	14.0 in. (356 mm)
Type 2	1,000 rpm – 1 3/8 in. (35 mm)	16.0 in. (400 mm)
Type 3	540 rpm – 1 3/4 in. (45 mm)	20.0 in. (500 mm)

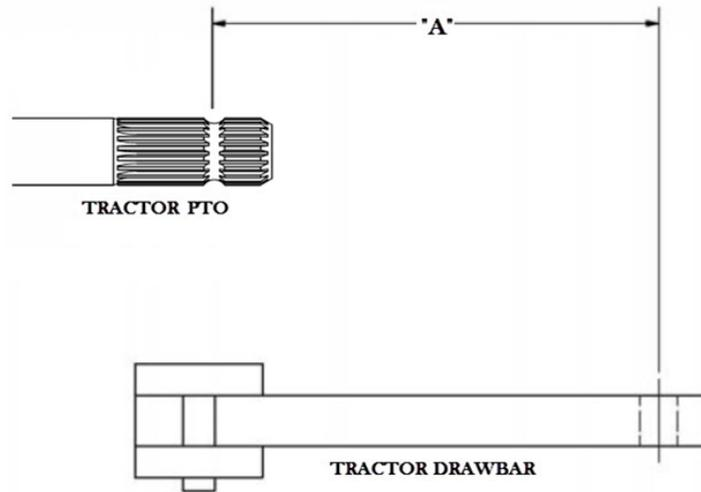

Figure 10 — Position of the Drawbar

2. Gently position the tractor in front of the mixer so that its drawbar faces the mixer's tongue.
3. Insert the locking pin and secure it with a pin.
4. Attach the safety chain between the mixer and the tractor using the provided anchor points.

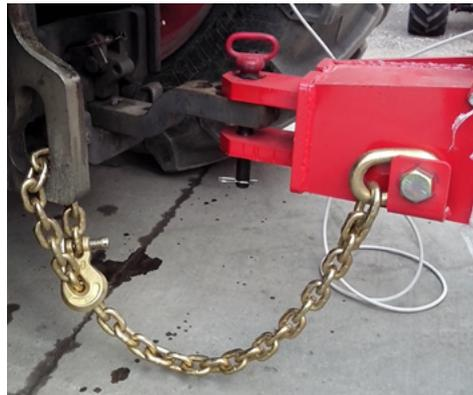

Figure 11 — Hitching to the Tractor

5. Remove the machine's jack stand and place it horizontally on its support.



3.2 Connecting the hydraulic and electrical systems

In order to use the SMARTMIX mixer, the tractor must have:

- At least one double-acting hydraulic distributor (one distributor corresponds to one 1/2 in. valve female inlet and outlet);
- One 12-V electrical power supply.

For optimal use, one of the valves should have a detent for continuous pumping.

The following tables indicate the number of hydraulic valves required for the selected options.

NOTE: If your tractor does not have enough hydraulic valves, the mixer can be operated with only one valve. Contact your dealer for more information.

NOTE: An additional hydraulic valve is required for the A950 and A1230 mixers to operate the tridem with tag axles.

Table 7 — Number of Double-Acting Hydraulic Valves Required for ST Models

Configuration	Number of additional valves required
Hydraulic restrictor blades	1
Inclined conveyor	2
Fixed horizontal conveyor	1
Horizontal conveyor with hydraulic offset	2



ANDERSON



Danger!

If the connections are reversed, the mixer functions will be reversed.

This could cause an accident!



Warning!

Relieve the pressure in the tractor's hydraulic system and ensure that the couplings are clean before connecting them. Dirt will contaminate the tractor's hydraulic oil.



Warning!

The recommended oil flow rate to use the SMARTMIX mixer effectively is 38–55 Lpm (10–15 US gpm).

NOTE:

When hitching to the tractor for the first time, put the blue cable ties (provided in the Anderson sleeve) on the tractor valves, the same way as for the mixer ones. This will make hitching easier in the future and avoid connection errors.

To connect the hydraulic and electrical systems:

1. Connect the hydraulic hoses by referring to the following table.

Function	Identification
Close the hatch	1 yellow cable tie
Open the hatch	2 yellow cable ties
Disengage the restrictor blades	1 red cable tie
Engage the restrictor blades	2 red cable ties
Turn the conveyor to the right	+/in
Turn the conveyor to the left	-/out
Offset the conveyor on the right	1 blue cable tie
Offset the conveyor on the left	2 blue cable ties

2. Ensure that the hydraulic hoses will not get tangled or stuck between the tractor and mixer, which causes premature wear and tear.
3. Connect the 12 V power cable for the computer.
4. Plug the rear lights into the 7-pin socket on the tractor.
5. Check that the tractor and machine turn signals correspond to one another.

3.3 Connecting the drive shaft



Warning! Always check the length of the drive shaft before hitching the machine to a different tractor. An improperly adjusted drive shaft may sustain damage that will not be covered by the warranty.



Warning! The machine's tongue must be placed below the drive shaft. If the bar hits the drive shaft, it could cause irreparable damage that is not covered by the warranty.

3.3.1 Checking the drive shaft length

The drive shaft supplied with the machine adjusts to most Category 2 and 3 tractors. However, its length needs to be checked when changing tractors.



Warning! A drive shaft that is too long for the tractor's PTO could damage the drive shaft and PTO.
A drive shaft that is too short could also be damaged.



ANDERSON

To ensure that the drive shaft is not too long:

1. Hitch the machine to the tractor (see "Hitching to the tractor" on page 57).
2. Without connecting the drive shaft to the tractor, steer the tractor as far as possible from the machine. In this position, the drive shaft is fully retracted in relation to the tractor.
3. Try to bring the drive shaft next to the tractor's PTO. If it is too long, shorten it.

To ensure that the drive shaft is not too short:

1. Hitch the machine to the tractor (see "Hitching to the tractor" on page 57).
2. Position the machine so that the drive shaft is fully extended (the machine must be in line with the tractor).
3. Ensure that when in use, the maximum length is less than "closed length + 1/3 closed length".
4. If the drive shaft is too short, contact your dealer.

In the example in Figure 12, the drive shaft will be long enough if it measures less than 1,613 mm (64 in.) when fully extended on your tractor. Ensure that you use the shortened drive shaft length as the closed length in your calculation.

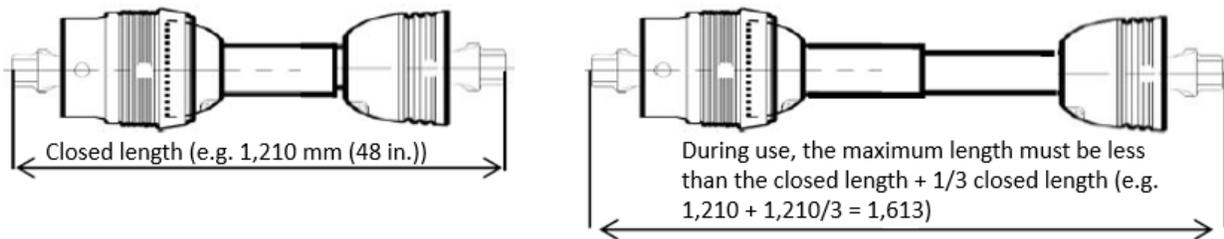

Figure 12 — Example Drive Shaft Length Measurement

3.3.2 Connecting the drive shaft

1. Disengage the PTO and turn off the tractor engine.
2. Connect the drive shaft to the tractor's PTO. The double universal joint must be on the tractor side.
3. Attach the drive shaft guard chains to hold it in place.

NOTE: The PTO speed varies depending on the machine model and options (see "Technical specifications" on page 15).

4. Ensure that the drive shaft will not collide with machine or tractor parts, regardless of the lift height.

NOTE: See the documentation provided by the drive shaft manufacturer.

3.3.3 Checking the slope angle of the drive shaft

Once the drive shaft has been connected, check its slope angle. A good slope angle will prevent damage to the drive shaft and reduce vibrations on the machine.

Table 8 and Figure 13 show whether the slope angles are suitable for the drive shaft or not based on its rotation speed.

Table 8 — Suitability of the Angle Based on Speed (in rpm)

Angle	540 rpm	1,000 rpm
0 to 5 degrees	Good	Good
6 to 9 degrees	Good	Average (vibrations and premature wear)
10 to 15 degrees	Average (vibrations and premature wear)	Poor
16 degrees or more	Poor	Poor

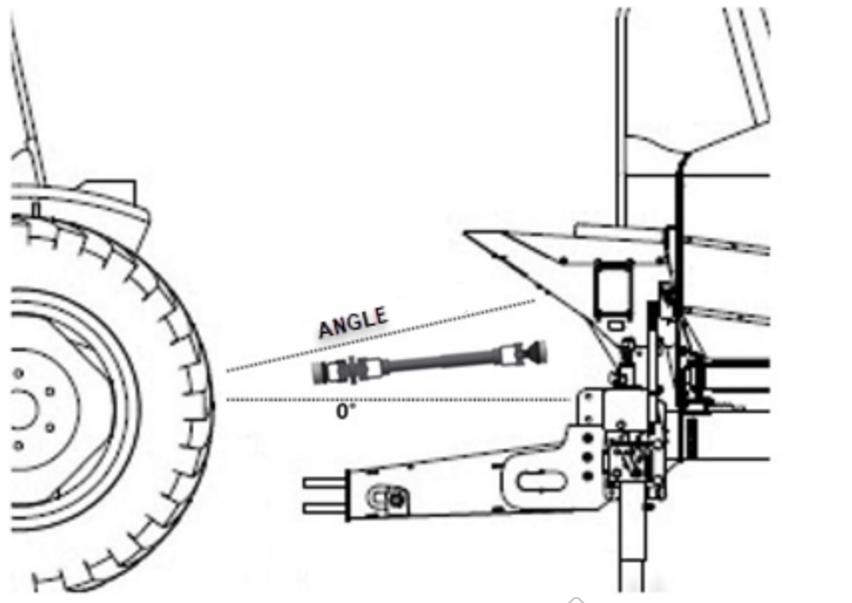

Figure 13 — Drive Shaft Slope Angle

NOTE: To decrease the slope angle of the drive shaft, you can reverse the tractor drawbar or adjust the height of the mixer's tongue.



ANDERSON

3.4 Unhitching



Danger!

Use extreme caution when hitching and unhitching the equipment.

Before proceeding, securely immobilize the equipment with the devices provided.

To unhitch the machine:

1. Position the machine on a level, stable surface, turn off the tractor engine and relieve the pressure in the hydraulic hoses.
2. Disconnect the hydraulic hoses.
3. Disconnect the power supply to the lights.
4. Put the jack in vertical position.
5. Remove the pin from the locking pin.
6. Uncouple the drive shaft and place it on its support.
7. Uncouple the mixer tongue from the tractor drawbar.



Danger!

When the mixer is not hitched to a tractor, make sure to properly immobilize it by putting chocks on each side of its wheels. Anderson Group does not provide chocks with the equipment.

3.5 Testing the rotating parts



Warning!

Before each use, even if empty, check that the mixing chamber is empty.

Ensure that nobody is nearby while testing and operating the machine.



Warning!

Put all safety devices in place and close the distribution hatch (es) before operating the rotating parts.

NOTE: Before starting the mixer, check the gearbox oil levels and grease all joints equipped with a grease fitting (see "Maintenance" on page 103).

NOTE: The technical specifications table (see "Technical specifications" on page 15) indicates the mechanical power the tractor PTO needs to rotate the mixing auger.

3.5.1 SMARTMIX with direct drive

To test the rotating parts:

1. Select the PTO that corresponds to the nominal rotation speed of the machine (540 or 1,000 rpm).

NOTE: For the nominal rotation speed, see the sticker on the front of the machine.

2. Accelerate until the PTO reaches the nominal rotation speed.
3. Climb the ladder and check that the auger is engaged and turning clockwise.



ANDERSON

3.5.2 SMARTMIX with two-speed gearbox

NOTE: For SMARTMIX mixers equipped with cable control for changing speed, attach the extra V-bracket supplied with the mixer to the inside of the tractor cab before using it for the first time.



To test the rotating parts at low speed:

1. Select low speed by putting the speed lever in the  position (see Figure 14).
2. If you cannot shift into low speed (the lever does not move all the way), rotate the tractor PTO, disengage it, and move the lever until the drive shaft almost completely stops rotating.
3. Select the 540 rpm (or 1,000 rpm) PTO on your tractor, then slowly engage it at idle.
4. Accelerate until the PTO reaches the nominal rotation speed.

To test the rotating parts at high speed, follow the same steps with the speed lever in  position (see Figure 14).

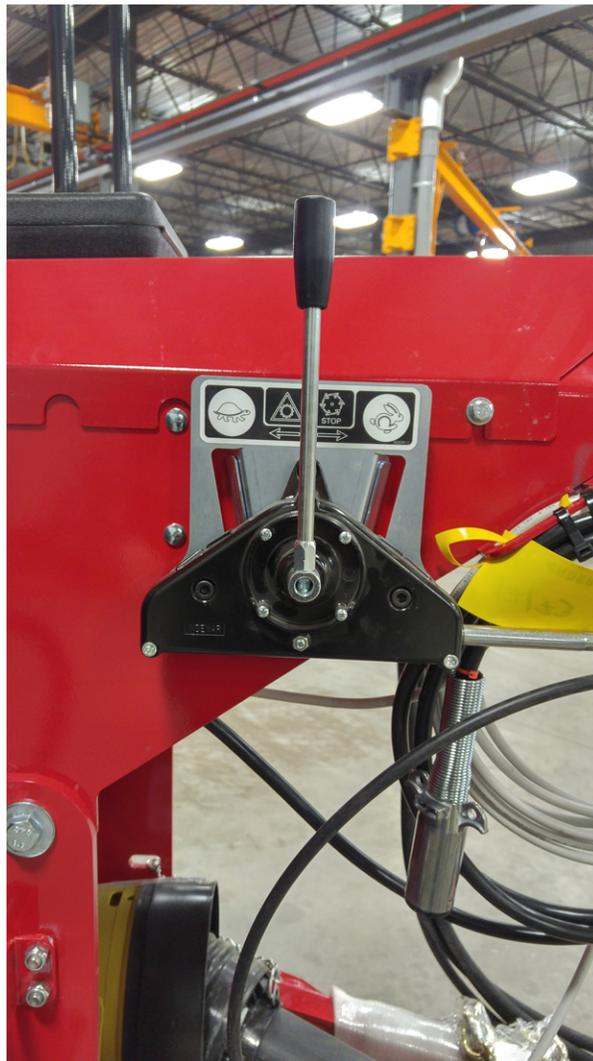

Figure 14 — Speed Lever



Important!

Never use the speed lever without first disengaging the tractor PTO.



Important!

If the speed lever is stuck in engaged position, stop the tractor engine to release the PTO.

4 Adjustments

4.1 Adjusting the hitch position

The mixer's tongue is normally adjusted for a tractor drawbar that is 432 mm (17 in.) from the ground (see Figure 15, B) for the A280, A380 and A450 models, and 483 mm (19 in.) from the ground for the A520, A700, A920, A950 and A1230 models.

If the tongue (see Figure 15, A) and the tractor drawbar (see Figure 15, B) differ in height by more than 50 mm (2 in.) for the A700, A920, A950 or A1230 models or 75 mm (3 in.) for the A280, A380, A450 and A520 models, you will need to adjust the height of the mixer's tongue.

NOTE: Take the measurements on a level surface when the machine is empty and unhitched.

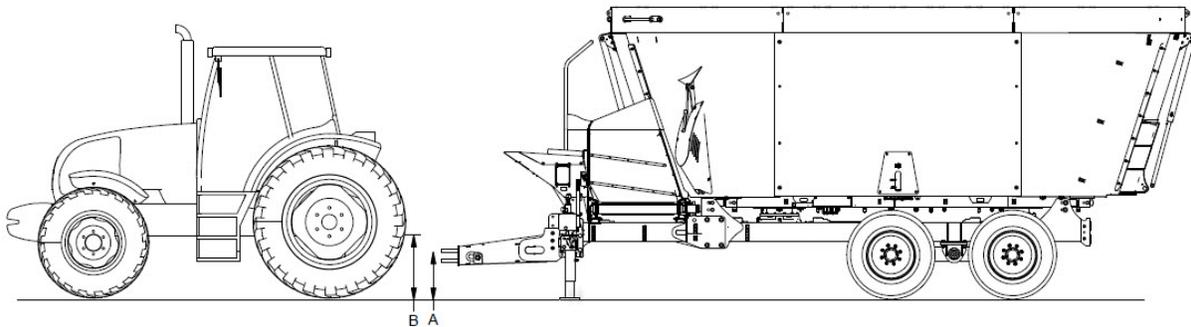

Figure 15 — Measurements for Hitching

The tongue (A) can be adjusted to different heights, depending on the model:

- A280, A380, A450 and A520: 250 to 1,075 mm (10 to 42 in.)
- A700, A920, A950 and A1230: 350, 450, 550 or 650 mm (14, 18, 22 or 26 in.)



Danger!

Before hitching the machine, ensure that the tractor's front axle is sufficiently weighted. The load on the front axle must be at least 20% of the empty weight of the tractor.



Danger!

Place ballast weights on the provided supports in accordance with the tractor manufacturer's instructions.



ANDERSON

To adjust the height of the mixer tongue:

1. Set up two jack stands to support the tongue.
2. Remove the mounting bolts from the hitch.
3. Using the jacks, adjust the height of the machine frame to align with the desired adjustment holes.
4. Insert the mounting bolts and remove the jack stands.

4.2 Adjusting the jack height

NOTE: Follow the transport instructions in the user guide for your SMARTMIX mixer (see "Safety tips for transport" on page 50).

The jack height is adjustable. Select the position that is most suitable for the tractor drawbar. To adjust the jack height:

1. Hitch the mixer to the tractor.
2. Remove the mounting bolts from the jack.
3. Slide the jack to the desired height.
4. Insert the mounting bolts into the jack where appropriate for the tractor drawbar.
5. Unhitch the mixer from the tractor.

NOTE: In transport mode, the jack must be folded up. For models equipped with a hydraulic jack, the lever must be placed on its support.

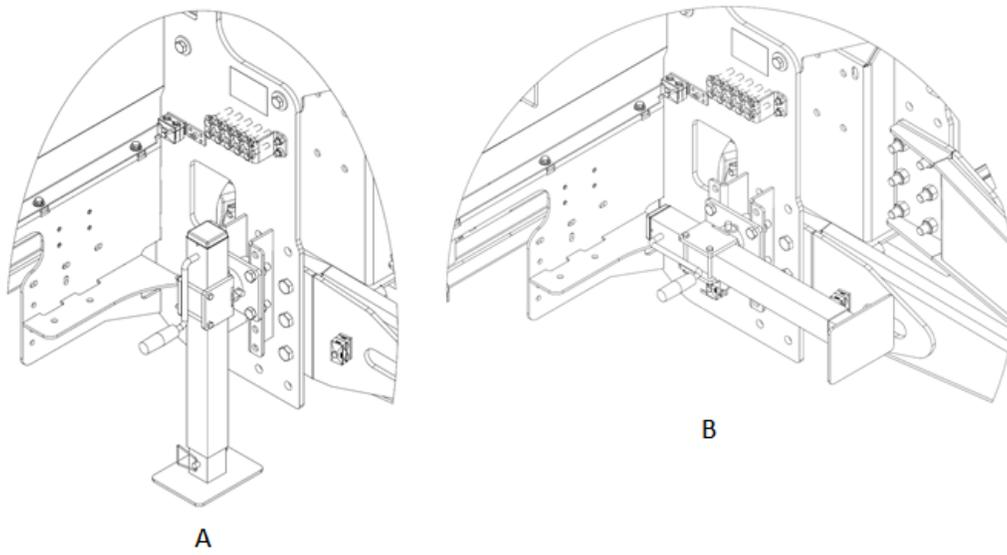

Figure 16 — Manual Jack Extended (A) and in Transport Position (B)

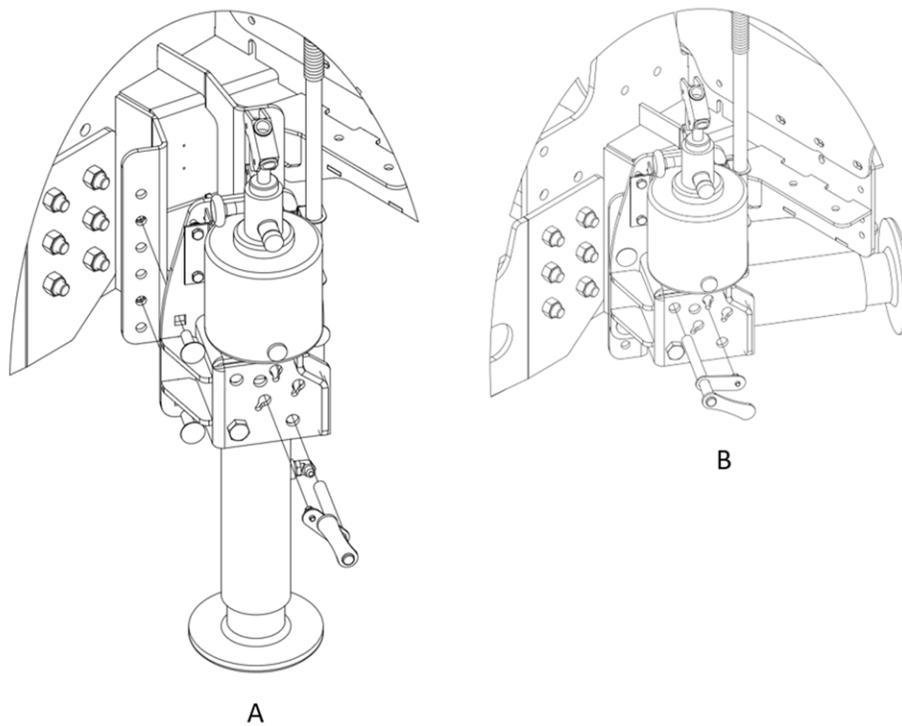

Figure 17 — Hydraulic Jack Extended (A) and in Transport Position (B)



ANDERSON

4.3 Adjusting the cut size



Danger!

As a safety precaution, always switch off the hydraulic system before proceeding.



Danger!

As a safety precaution, this adjustment must only be done when the machine is off.

The cut size depends on the position of the two restrictor blades in the mixing chamber. If the restrictor blades are positioned toward the inside of the mixing chamber (restrictor blades retracted), the cut size will be shorter. If they are toward the outside of the mixing chamber (restrictor blades extended), the cut size will be longer. The position can be adjusted using the stroke limiter bolts (Figure 18, A).

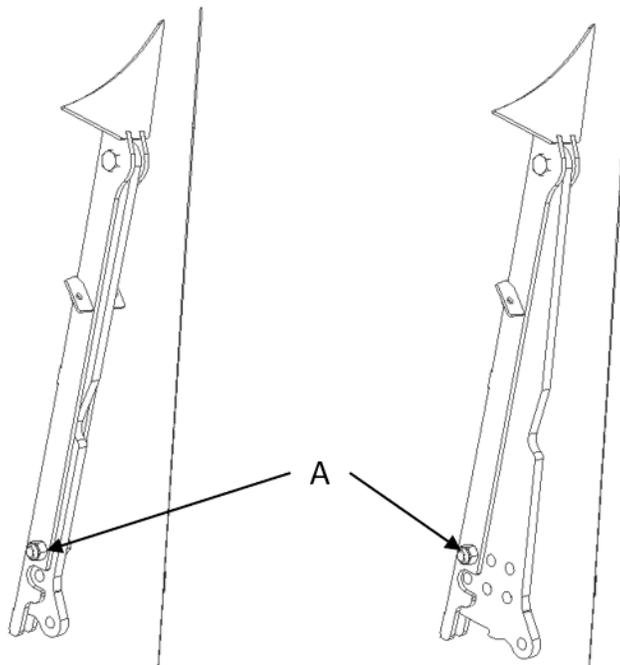

Figure 18 — Restrictor Blades Retracted (Left) and Extended (Right)

4.3.1 Adjusting the cut size with hydraulic restrictor blades (option)

1. Using the hydraulic controls, move the restrictor blades all the way out of the mixing chamber (see Figure 19-B).
2. Stop the tractor.
3. Remove the restrictor blade guards on each side of the machine by unscrewing the four (4) bolts on each guard.
4. Insert the stroke limiter bolt in the hole that corresponds to the desired position (see Figure 20).
5. Put the guards back on.

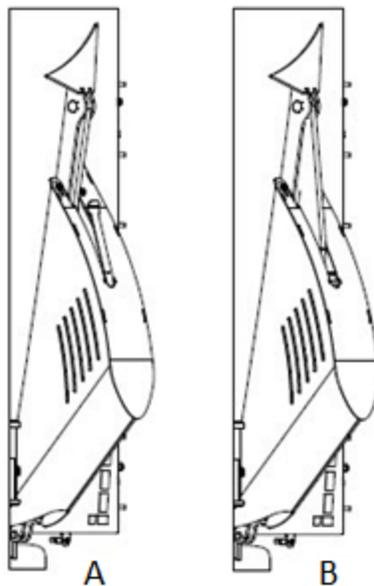

Figure 19 — Restrictor Blades In (A), Restrictor Blades Out (B)

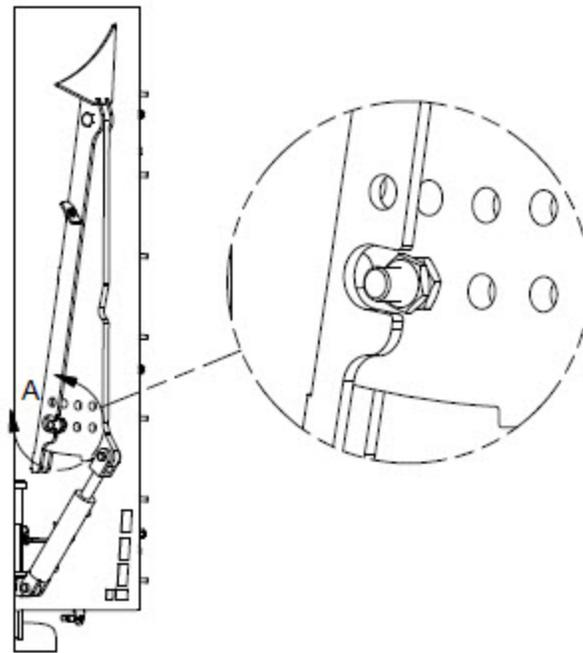

Figure 20 — Hydraulic Cylinder Stroke Limiter for the Restrictor Blades

4.4 Adjusting the hatch openings

The discharge rate depends on the conveyor speed (see "Adjusting the conveyor speed" on page 78) and the hatch openings. The more a hatch is open, the higher the discharge rate.

The front hatch on your SMARTMIX is equipped with a visual openness indicator. 0 indicates that the hatch is completely closed, and 6 indicates that the hatch is completely open (see Figure 21).

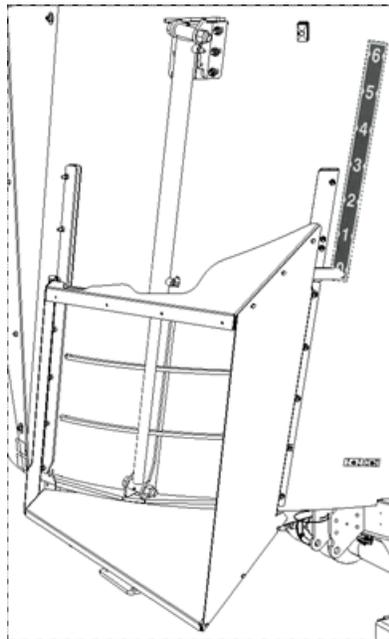

Figure 21 — Openness Indicator

The hatch is adjusted directly using the tractor's hydraulic commands.

If your SMARTMIX is equipped with both front and rear hatches, the hatches are adjusted using the same tractor hydraulic controls via a two-position selector switch (see "Controls" on page 83).

4.5 Adjusting the horizontal conveyor offset

 Danger!	<p>When driving on public roads, ensure that the conveyor is centred.</p>
--	--

4.5.1 Fixed horizontal conveyor (standard for FD models)

The fixed horizontal conveyor can be in any of the following five positions:

- Centre position;
- Offset by 150 mm (5.9 in.) on the right;
- Offset by 375 mm (14.75 in.) on the right;
- Offset by 150 mm (5.9 in.) on the left;
- Offset by 375 mm (14.75 in.) on the left.

Select the position that best suits your distribution.

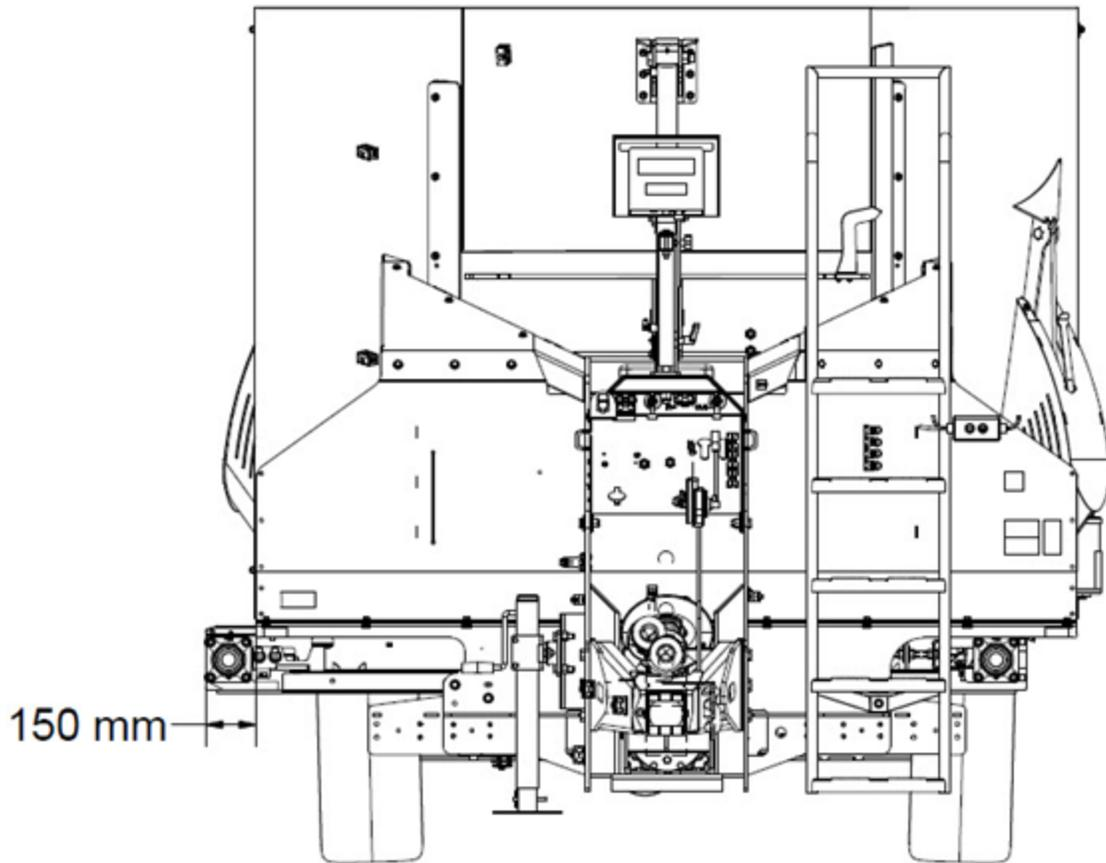

Figure 22 — Fixed Horizontal Conveyor Offset by 150 mm (5.9 in.) on the Left

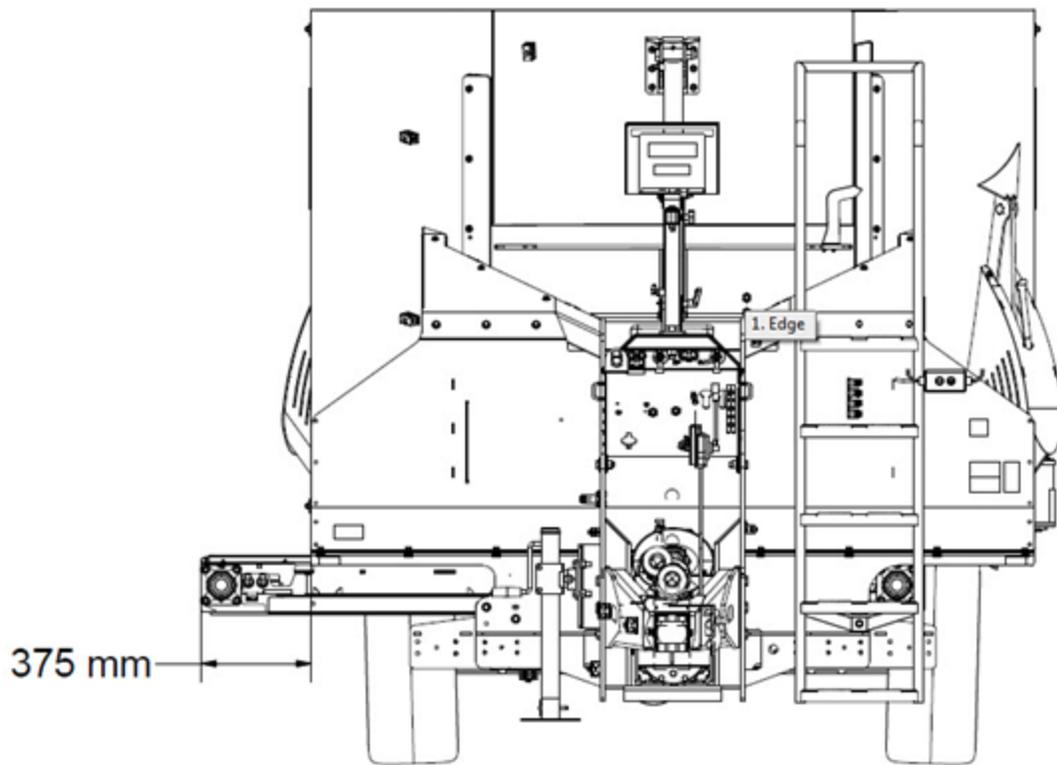

Figure 23 — Fixed Horizontal Conveyor Offset by 375 mm (14.75 in.) on the Left

The fixed horizontal conveyor is adjusted using hardware (see Figure 24).

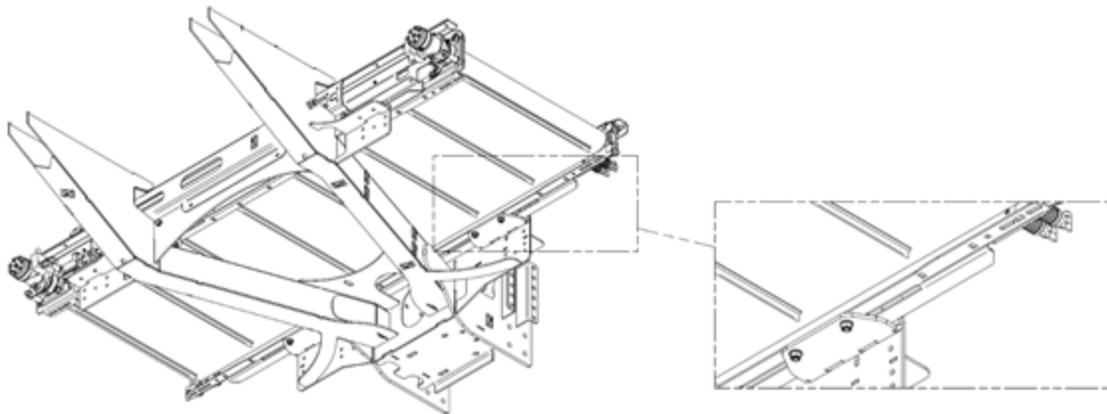

Figure 24 — Adjusting the Offset of the Fixed Horizontal Conveyor



ANDERSON

4.5.2 Hydraulic horizontal conveyor (option)

The hydraulic horizontal conveyor can be offset by 0 to 375 mm (0 to 14.75 in.) on the left or right using the tractor's hydraulic controls.

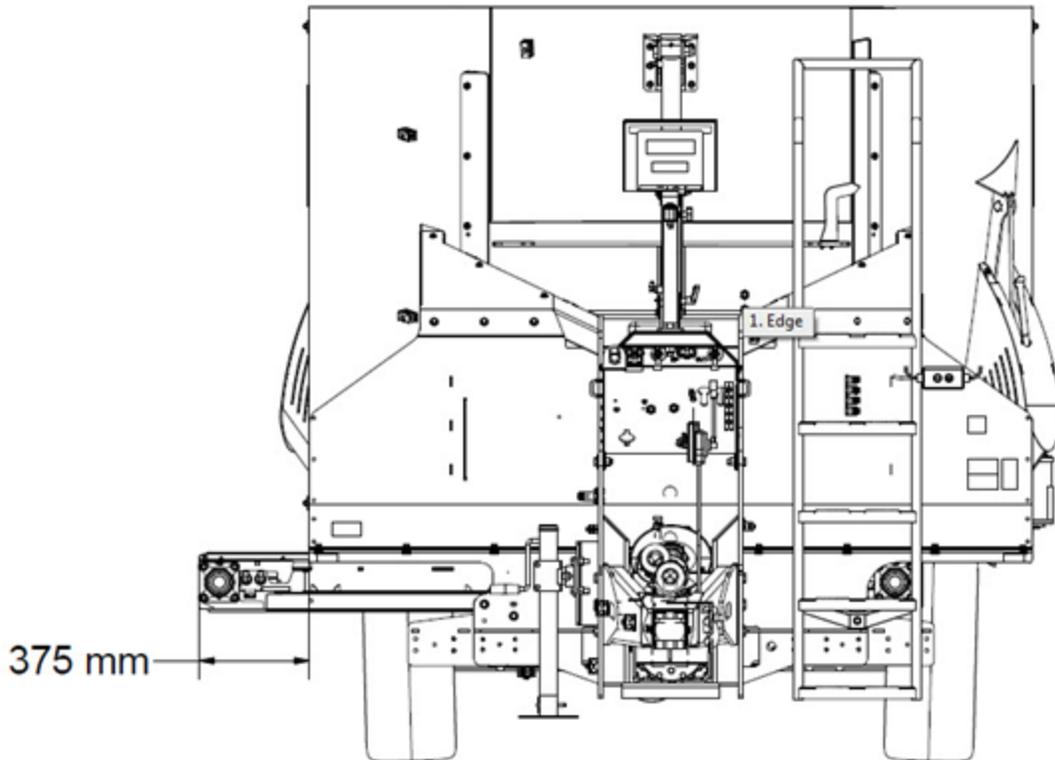

Figure 25 — Hydraulic Horizontal Conveyor Offset by 375 mm (14.75 in.) on the Left

4.6 Adjusting the conveyor speed

The discharge rate depends on the hatch openings (see "Adjusting the hatch openings" on page 74) and the conveyor speed.

The conveyor speed is adjusted via the two flow restrictors at the opening of the mixer nose.

Adjust flow restrictor A (see Figure 26) if discharging to the right of the machine, and adjust flow restrictor B (see Figure 26) if discharging to the left of the machine.

To adjust the conveyor speed:

1. Turn the flow restrictor knob to increase (+) or decrease (-) the conveyor speed.

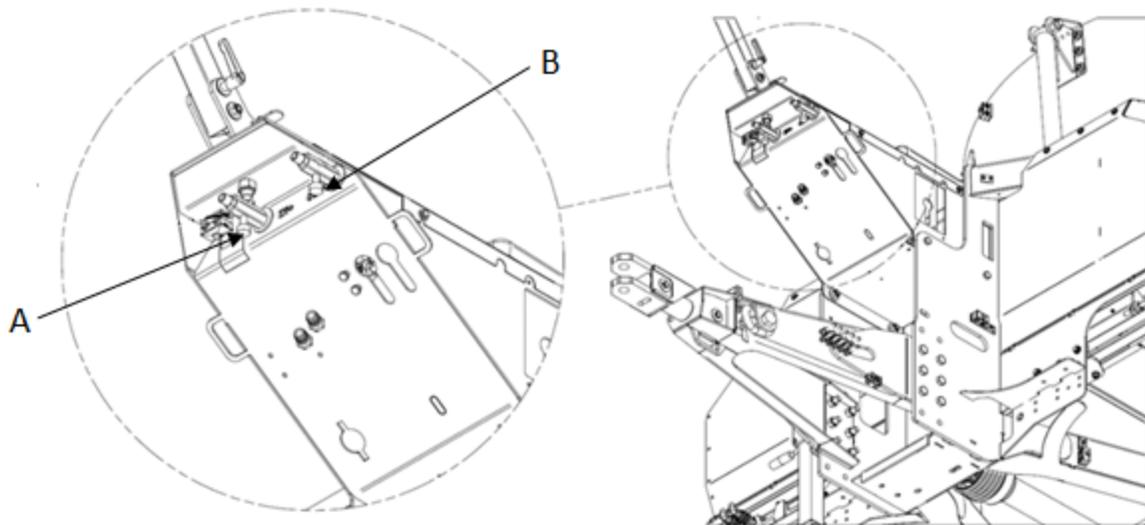

Figure 26 — Flow Restrictor

4.7 Adjusting the articulated support for the DG500 scale system

The articulated support for the DG500 scale system adjusts the position of the computer. Figure 27 shows the different possible settings.

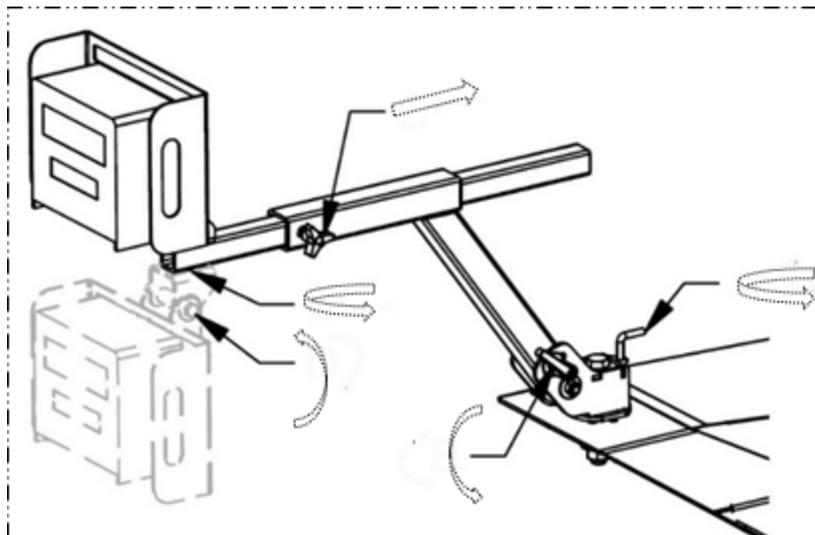

Figure 27 — Articulated Support for the DG500 Computer



ANDERSON

4.8 Adjusting the angle of the inclined conveyor (option)

When the machine is operating, the inclined conveyor must be completely lowered (see Figure 29). In transport mode, it must be completely raised (see Figure 28).

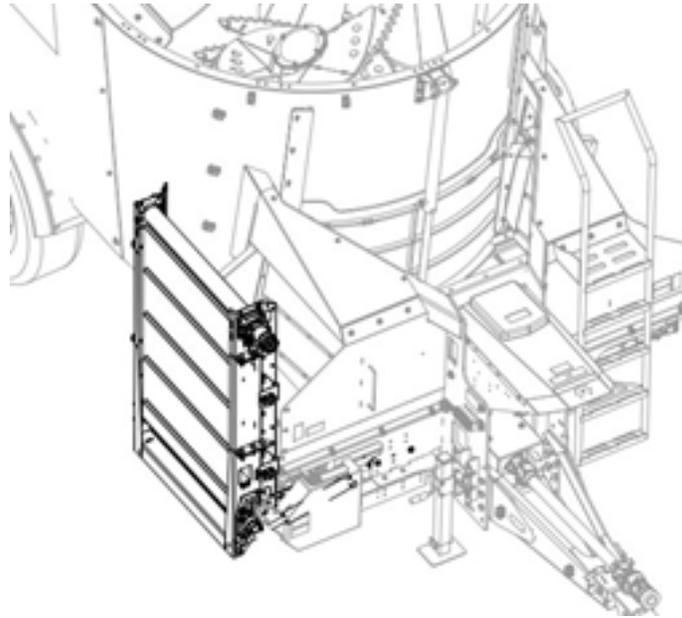

Figure 28 — Inclined Conveyor Raised

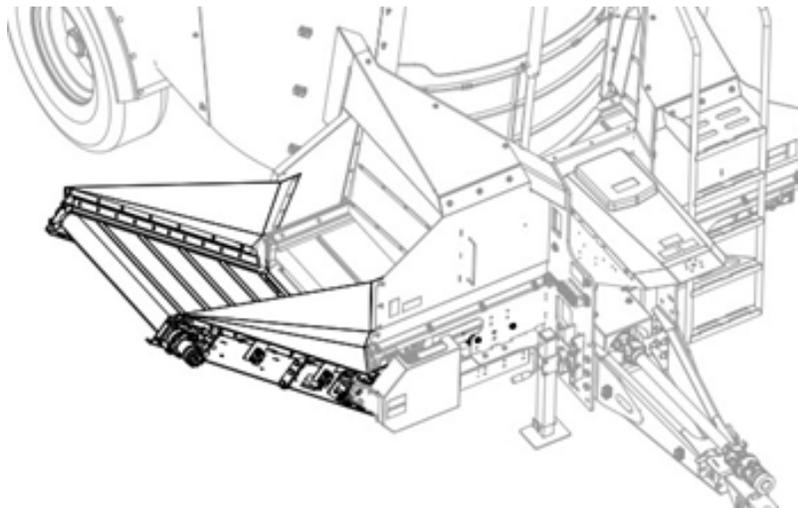

Figure 29 — Inclined Conveyor Lowered

The width of the conveyors can be adjusted using the tractor's hydraulic controls.

4.9 Adjusting the auger knives



Use safe and stable means of access and ensure that the mixing augers and the inside of the mixing chamber are clean.

Wear protective equipment (gloves, goggles, etc.) and use appropriate tools.

The mixing augers can have up to 10 cutting knives (standard augers) or up to 12 cutting knives (elongated augers). The recommended knife configuration is shown in Figure 30.

For a shorter or faster cut, install additional knives in the available spots, starting from the bottom.

For a less aggressive (longer) cut, install the knives in retracted position or remove knives starting from the second from the bottom.

The sixth knife from the bottom is the special JORDAN knife. It is positioned to prevent jams in mixers with multiple augers. If your mixer has two or three mixing augers and material gets jammed between the augers, put the JORDAN knife in the extended position. When there are no jams, leave the JORDAN knife retracted to avoid using more power unnecessarily.

NOTE: In Figure 30, the JORDAN knife is shown in retracted position.

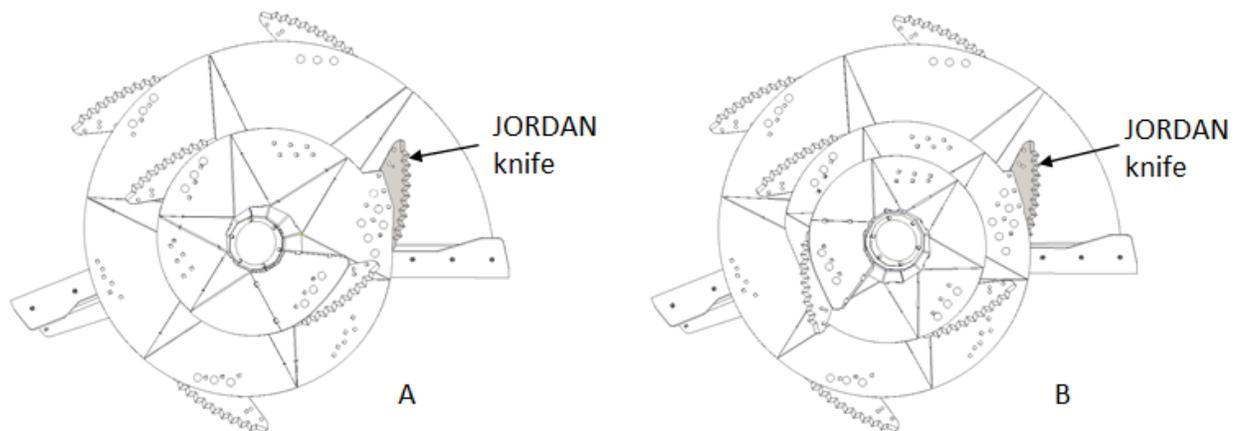

Figure 30 — Knife Positions for Standard Augers (A) and Elongated Augers (B)

4.10 Adjusting the hay retention ring

The hay retention ring can be installed so that it points into or out of the mixing chamber, as shown in Figure 31.



ANDERSON

To decrease the loading height, install the ring pointing into the mixing chamber (left image).

To increase the capacity of the machine and reduce the power that is required for mixing, install the ring pointing out of the mixing chamber (right image).

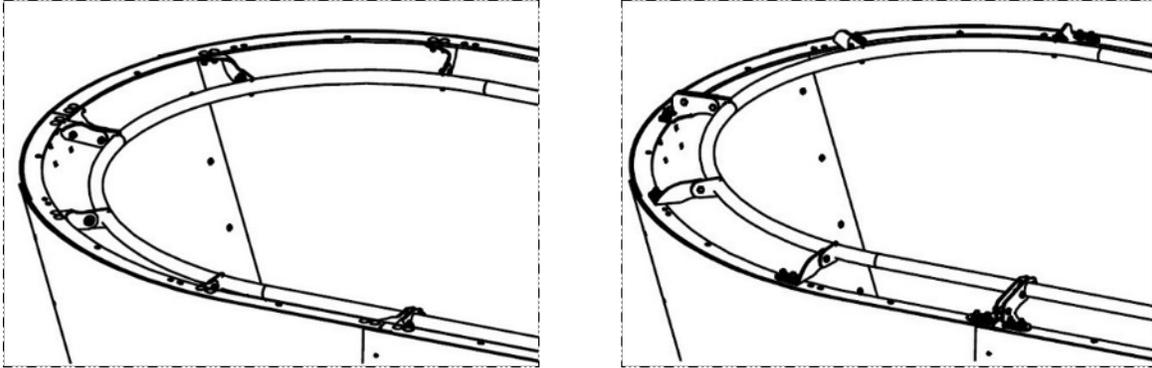

Figure 31 — Adjusting the Hay Retention Ring

5 Operation

5.1 Controls

All functions are operated using the tractor's hydraulic controls.

NOTE: For more information about the tractor's hydraulic controls, see the tractor operator's manual.

5.1.1 DG500 scale system

The DG500 scale system is a programmable weight indicator that lets you enter your feed recipes.



Figure 32 — DG500 Scale System

NOTE: For more information about the DG500, see the operator's manual provided with your mixer.

5.1.2 Hatch selector switch

For SMARTMIX mixers equipped with both front and rear hatches, a hatch selector switch is provided to control both hatches with a single hydraulic valve.



Figure 33 — Hatch Selector Switch

Table 9 — Description of the Hatch Selector Switch Controls

Control	Meaning
Light off	Front hatch is operating
Light on	Rear hatch is operating

5.2 Loading and mixing

1. Position the machine beside the product to load, ideally on a level surface for a more accurate weight reading. Aligning the drive shaft is also recommended to dampen vibrations.
2. Ensure that the distribution hatches are closed.



Never remove material by hand or with a tool when the machine is running.



When loading, ensure that your loading tool does not touch the mixing chamber or auger.

NOTE: Load long and low-density products first, followed by concentrates and minerals, silage, and then liquids.

NOTE: With a twin- or triple-auger SMARTMIX (A520, A700, A920, A950, A1230), load the material between the augers to best distribute it within the mixing chamber.

3. Ensure that the restrictor blades are suitably positioned for the mixture.

NOTE: The further the restrictor blades are inside the mixing chamber, the faster and finer the cutting will be. Remove the restrictor blades from the mixing chamber to avoid damaging products such as corn silage.

5.2.1 Loading long products

4. If your machine has the optional two-speed gearbox, select high speed.
5. Load the long fibre (straw, hay, baleage, etc.).

NOTE: To reduce the cutting time, you can add a bucket of silage to the long fibre.

6. Once all the fibre has been loaded, let the machine run for a few minutes until the desired cut size is reached.

5.2.2 Loading supplements

7. Load the supplements (powders, pellets, molasses, etc.).

NOTE: Supplements mix in better if they are loaded before the short products.

8. Continue cutting the mixture of long products and supplements.

5.2.3 Loading short products and liquids

9. Disengage the restrictor blades (out of the mixing chamber).

NOTE: Remove the restrictor blades from the mixing chamber to avoid damaging products such as corn silage.

10. If your machine has the two-speed option, select low speed.
11. Load the short fibre (grass silage, corn, etc.) and liquids.
12. Once all the materials have been loaded, let the machine run for 2 or 3 minutes to homogenize the mixture (times may vary based on the feed type).

NOTE: For best results, the mixing chamber should be filled to at least 6 in. from the top.

To increase the capacity of the mixing chamber, install an auger extension and capacity extensions.



ANDERSON

5.3 Weighing

NOTE: The scale system is a load indicator intended to control feed rations made using Anderson machines. It must NEVER be used as a scale system for commercial transactions.

The weight indicator instruction manual contains all the information about using the weight indicator.

The manual is supplied with the machine and is located in the storage compartment.

5.4 Distribution

1. Ensure that the restrictor blades are disengaged (outside the mixing chamber).
2. Engage the tractor's PTO:
 - A280, A380, A450, A520 and A700: 540 or 1,000 rpm.
 - A920, A950 and A1230: 1,000 rpm.
3. Adjust the conveyor:
 - For machines with a hydraulic horizontal conveyor, use the hydraulic tractor controls to adjust the offset of the conveyor.
 - For machines with an inclined conveyor, use the hydraulic tractor controls to adjust the incline of the conveyor.
4. Turn on the conveyor and select an appropriate speed for the ration.
5. Open the distribution hatch as far as needed based on the texture and quantity of the mixture to distribute. For fibre-based rations, open the hatch two thirds of the way. For corn-based rations, open the hatch halfway.
6. Move the tractor forward at a suitable speed for the quantity of material to distribute.
7. At the end of distribution, select high speed (if your machine has the optional two-speed gearbox) to help empty the mixing chamber completely.
8. Once distribution is complete, stop the tractor PTO.
9. Close the distribution hatch.
10. Raise the inclined conveyor or centre the horizontal conveyor.
11. Depressurize the hydraulic system.

5.5 Cleaning the magnetic extractor



Warning!

Before doing any work in the mixing chamber, follow the safety guidelines in "Mixing chamber" on page 54.

After each distribution, the magnetic extractor must be cleaned to prevent any metal particles from getting into the next mixture.

1. Put the safety valve lever (A) for the hydraulic hatches in closed position (1) to prevent the hatches from closing accidentally.
2. Remove any dirt or particles that were collected by the magnetic extractor (B).
3. Once the operation is complete, put the safety valve lever (A) for the hydraulic hatches in open position.

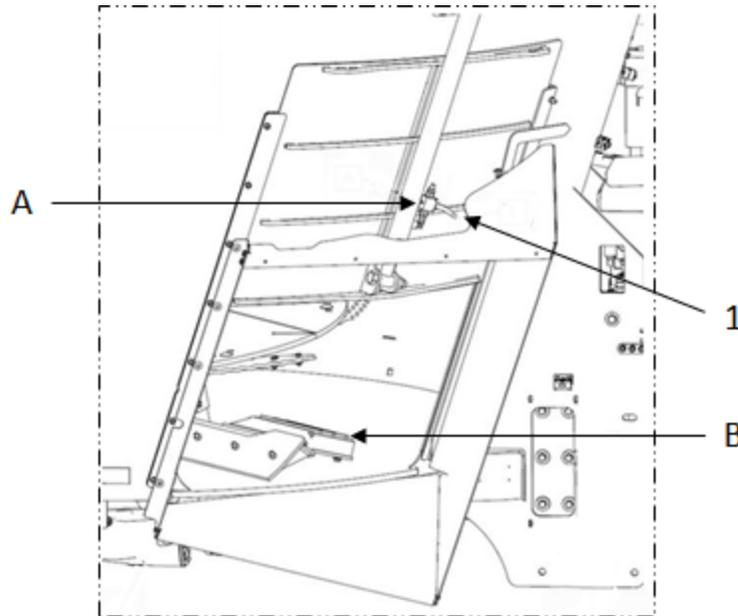

Figure 34 — Cleaning the Magnetic Extractor

5.6 Using the tridem axle

To connect the tridem axle:

1. Locate the hydraulic hoses attached to the tridem with tag axles.
2. Connect the hydraulic hoses to a hydraulic distributor that can be used in float mode.

NOTE: Connect the hydraulic hose with a cable tie on the pressure (+) side of the tractor.

Forward operation:

- If you want your front and rear axles of your tridem to be tag, put the hydraulic distributor connected to the tridem axle's hydraulic system in float mode.
- To disengage the tag axles when travelling on long straight stretches, actuate the hydraulic valve until the tridem axle wheels are parallel to the mixer frame.

Reverse operation:

Actuate the hydraulic valve until the tridem axle wheels are parallel to the mixer frame.



ANDERSON



Warning!

In reverse operation, the tag axes must always be parallel to the frame.

6 Troubleshooting

 Warning!	<p>See "Safety tips for maintenance and repairs" on page 53 before beginning troubleshooting.</p>
--	---

 Warning!	<p>For any other issues, please contact your dealer or our technical service department.</p>
--	--

6.1 Common problems

Problem	Possible cause	Solution
The mixing auger (s) are no longer turning.	The mixing auger (s) were overloaded and the shear bolt broke.	Replace the shear bolt (see "Replacing the shear bolts" on page 94).
The shear bolts break often.	The scrapers at the bottom of the augers are not adjusted properly.	Replace or adjust the scrapers (see "Adjusting or replacing the auger scrapers" on page 121).
	The restrictor blades are too far inside the mixing chamber.	Reduce the travel of the restrictor blades using the stroke limiter bolt (see "Adjusting the cut size" on page 72).
The mixing augers will not turn. The shear bolt breaks every time.	A mixing auger is blocked.	<ol style="list-style-type: none"> 1. Engage the two-speed gearbox at low speed. 2. Remove the restrictor blades from the mixing chamber. 3. Open the unloading hatch(es). For twin- or triple-auger mixers, disengage the PTO for the second mixing auger.
The scale is defective.	There is a problem with the scale system.	Contact your dealer.



ANDERSON

Problem	Possible cause	Solution
The mixing chamber does not get completely empty during distribution.	The scrapers are worn or incorrectly adjusted.	Replace or adjust the scrapers (see "Adjusting or replacing the auger scrapers" on page 121).
	The mixing augers are rotating too slowly.	Increase the tractor's engine speed and select high speed on the two-speed gearbox. Note: Only do this when almost no material is left in the mixing chamber.
The conveyor belt slips during distribution.	The conveyor belt is not tight enough.	Adjust the conveyor belt tension (see "Checking and adjusting the conveyor tension" on page 123).
The conveyor keeps slapping.	The pulley scrapers inside the conveyor are adjusted incorrectly.	Move the scrapers slightly back from the pulleys.
A bale is stuck between two mixing augers.	The knives are positioned incorrectly.	Make sure that the JORDAN knife is all the way out on each auger (see "Adjusting the auger knives" on page 81).
The mixture is of poor quality.	The mixing augers are not synchronized (for twin- and triple-auger mixers).	Synchronize the mixing augers (see "Replacing the shear bolts" on page 94).
	The knives are positioned incorrectly.	Make sure that the JORDAN knife is all the way out on each auger (see "Adjusting the auger knives" on page 81).
	The mixer is inclined.	Level the mixer (see "Adjusting the hitch position" on page 69).
	The mixing augers are not rotating fast enough.	Adjust the rotation speed (see "SMARTMIX with two-speed gearbox " on page 66).
	The auger knives are worn.	Sharpen the knives (see "Adjusting or replacing the auger scrapers" on page 121) or replace them with new knives.

Problem	Possible cause	Solution
The DG500 scale system is not turning on.	The three-prong plug between the tractor and machine has been unplugged.	Plug it back in.
	The tractor's power supply is defective.	<ol style="list-style-type: none"> 1. Check the tractor's fuse. 2. Check the tractor's electrical system.
	There is an electrical issue with the weight indicator.	Contact your dealer.
	The power cable fuse blew.	Replace the fuse.



ANDERSON

Problem	Possible cause	Solution
The machine requires too much power.	The PTO speed is too high.	Check that the tractor is using the correct PTO: <ul style="list-style-type: none"> • A280, A380, A450, A520 and A700: 540 or 1,000 rpm • A920, A950 and A1230: 1,000 rpm.
	The restrictor blades are inside the mixing chamber.	Move the restrictor blades all the way out of the mixing chamber or reduce their travel (see "Adjusting the cut size" on page 72).
	The hay retention ring is preventing material from circulating at the top. The mixing chamber is at capacity.	Add a capacity extension to increase the mixing chamber capacity. OR Install the hay retention ring in reverse (see "Adjusting the hay retention ring" on page 81).
	The high-performance auger knives are out (A700 and A1230 only).	Retract the knives on the mixing auger (see "Adjusting the auger knives" on page 81).
	The scrapers are adjusted incorrectly.	Adjust the clearance between the scraper and the bottom to 3 mm (1/8 in.) (see "Adjusting or replacing the auger scrapers" on page 121).
	Material has accumulated inside the auger.	Open the access hatch (see Figure 48) and clean the inside of the auger.
	The mixing augers are not synchronized (for twin- and triple-auger mixers).	Synchronize the mixing augers (see "Replacing the shear bolts" on page 94).
	The mixer is inclined.	Level the mixer.

6.2 Common problems with the control system

Problem	Possible cause	Solution
The hydraulic system is not working properly.	One of the hydraulic return hoses is not connected properly.	Reconnect the hydraulic hose.
	The hydraulic lines are leaking.	Inspect the hydraulic lines to locate the leak and repair them, if necessary.



ANDERSON

6.3 Replacing the shear bolts

6.3.1 A380 and A450 SMARTMIX

Single-auger SMARTMIX mixers are equipped with a yoke that protects the entire drive train. The yoke is located on the secondary drive shaft. If the shear bolt breaks:

1. Disengage the PTO, turn off the tractor and uncouple the drive shaft.
2. Remove the piece of shear bolt from the yoke (see Figure 35, A).
3. Insert a new bolt (available on the spare bolt support) (Figure 36) (see Table 17 — Power Take-Off (PTO) Shear Bolts in "Appendix A — SMARTMIX maintenance summary tables" on page 132 for the type of shear bolt to use for your mixer model).
4. Put the drive shaft back in place.

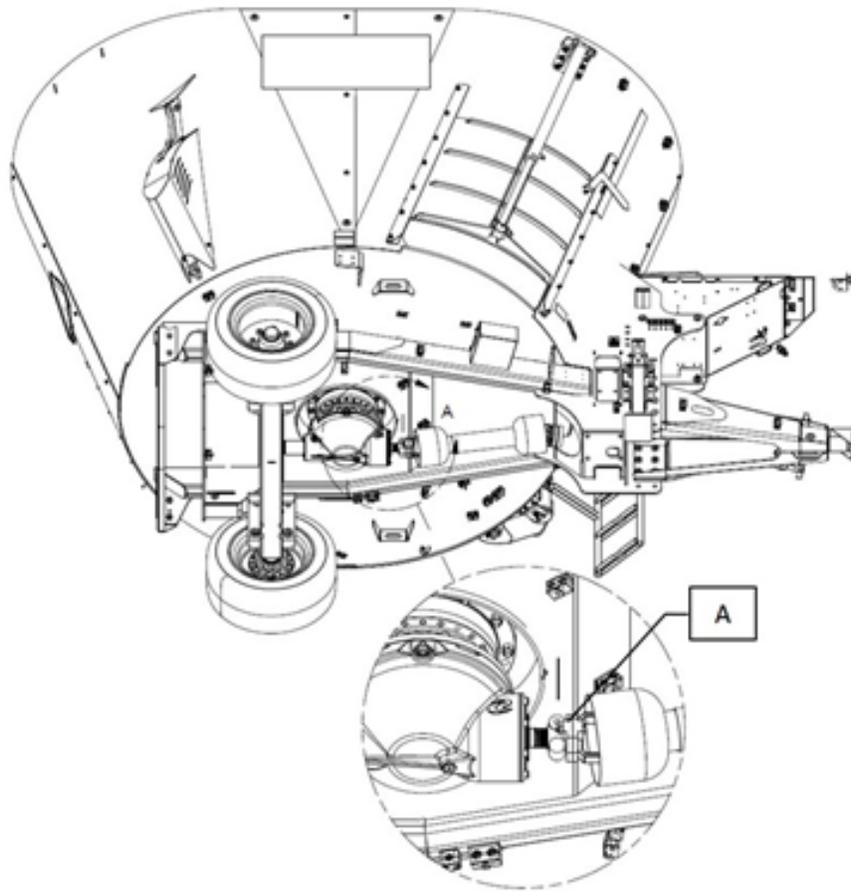

Figure 35 — Location of the Shear Bolt Yoke on a Single-Auger SMARTMIX

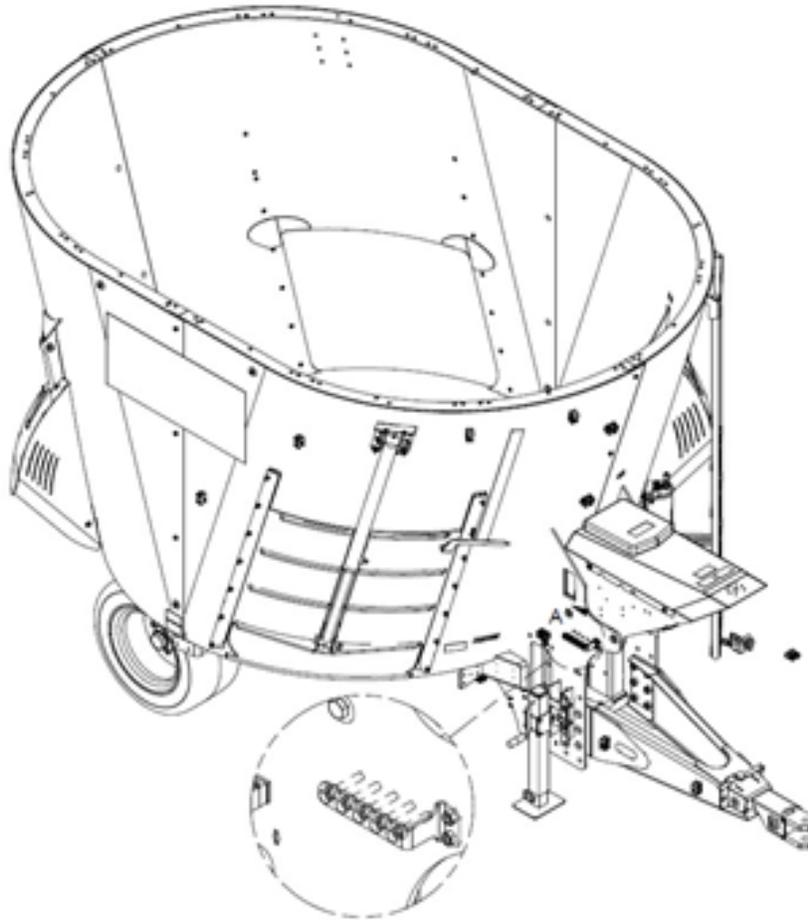

Figure 36 — Location of the Shear Bolts on the A280 and A380 SMARTMIX

6.3.2 A520, A700 and A920 SMARTMIX

Twin-auger SMARTMIX mixers have two yokes. The first yoke is located on the secondary drive shaft and protects the two planetary gearboxes for the mixing augers (Figure 37, A). The second yoke is located after the first gearbox for the rear auger (Figure 37, B).

If the shear bolt for the front auger breaks (Figure 37, A):

1. Disengage the PTO, turn off the tractor and uncouple the drive shaft.
2. Remove the piece of shear bolt from the yoke (Figure 37, A).
3. Insert a new bolt (available on the spare bolt support) (Figure 38)(see Table 17 — Power Take-Off (PTO) Shear Bolts in "Appendix A — SMARTMIX maintenance summary tables" on page 132 for the type of shear bolt to use for your mixer model).
4. Put the drive shaft back in place.



ANDERSON

If the shear bolt for the rear auger breaks (Figure 37, B):

1. Disengage the PTO, turn off the tractor and uncouple the drive shaft.
2. Remove the piece of shear bolt from the yoke (Figure 37, B).
3. Insert a new bolt (available on the spare bolt support) (Figure 38) (see Table 17 — Power Take-Off (PTO) Shear Bolts in "Appendix A — SMARTMIX maintenance summary tables" on page 132 for the type of shear bolt to use for your mixer model).
4. Put the drive shaft back in place.

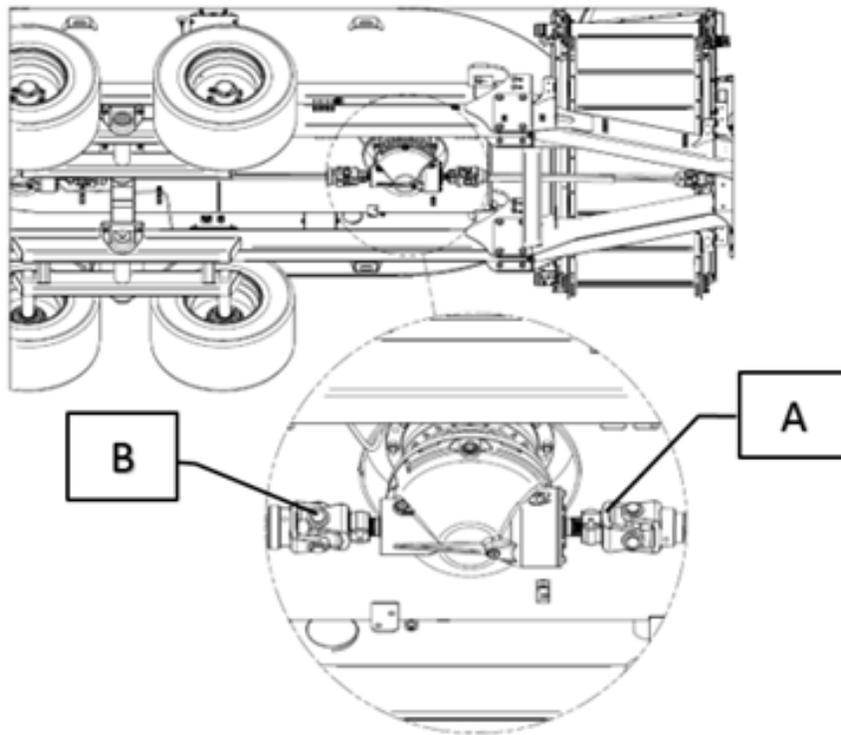

Figure 37 — Location of the Shear Bolt Yokes on a Twin-Auger SMARTMIX

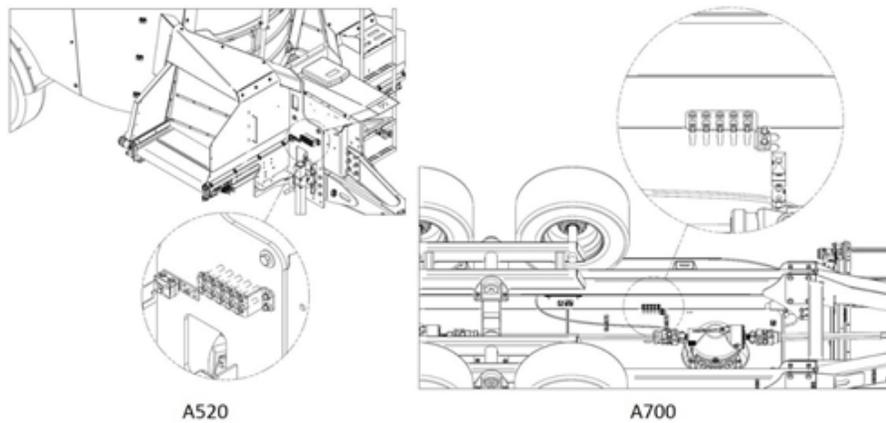

Figure 38 — Location of the Shear Bolts on the A520 and A700 SMARTMIX

	<p>After emptying the machine, check the indexation of the mixing augers (their positions in relation to each other). The front auger scraper (Figure 39, C) and rear auger scraper (Figure 39, D) must be offset from each other by 90°.</p>
---	--

To synchronize the mixing augers:

1. Disconnect the drive shaft from the rear auger.
2. Using the tractor PTO, rotate the front auger into Position C and the rear auger into Position D.
3. Once the augers are synchronized, reconnect the drive shaft to the rear auger.

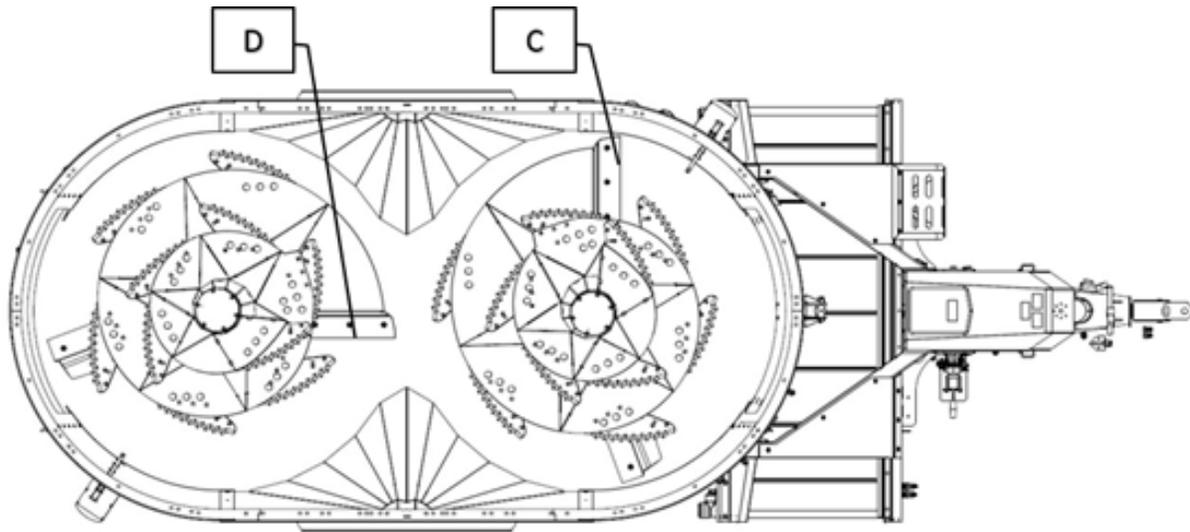

Figure 39 — Synchronizing the Mixing Augers (Two Augers)

6.3.3 A950 and A1230 SMARTMIX

Triple-auger SMARTMIX mixers have three yokes. The first yoke is located on the secondary drive shaft and protects the three planetary gearboxes for the mixing augers (Figure 40, A). The second yoke is located after the first gearbox for the middle auger (Figure 40, B). The third yoke is located after the second gearbox for the rear auger (Figure 40, C).

If the shear bolt for the front auger breaks (Figure 40, A):

1. Disengage the PTO, turn off the tractor and uncouple the drive shaft.
2. Remove the piece of shear bolt from the yoke (Figure 40, A).
3. Insert a new bolt (available on the spare bolt support) (Figure 41) (see Table 17 — Power Take-Off (PTO) Shear Bolts in "Appendix A — SMARTMIX maintenance summary tables" on page 132 for the type of shear bolt to use for your mixer model).
4. Put the drive shaft back in place.

If the shear bolt for the middle auger breaks (Figure 40, B):

1. Disengage the PTO, turn off the tractor and uncouple the drive shaft.
2. Remove the piece of shear bolt from the yoke (Figure 40, B).
3. Insert a new bolt (available on the spare bolt support) (Figure 41) (see Table 17 — Power Take-Off (PTO) Shear Bolts in "Appendix A — SMARTMIX maintenance summary tables" on page 132 for the type of shear bolt to use for your mixer model).
4. Put the drive shaft back in place.

If the shear bolt for the rear auger breaks (Figure 40, C):

1. Disengage the PTO, turn off the tractor and uncouple the drive shaft.
2. Remove the piece of shear bolt from the yoke (Figure 40, C).
3. Insert a new bolt (available on the spare bolt support) (Figure 41) (see Table 17 — Power Take-Off (PTO) Shear Bolts in "Appendix A — SMARTMIX maintenance summary tables" on page 132 for the type of shear bolt to use for your mixer model).
4. Put the drive shaft back in place.

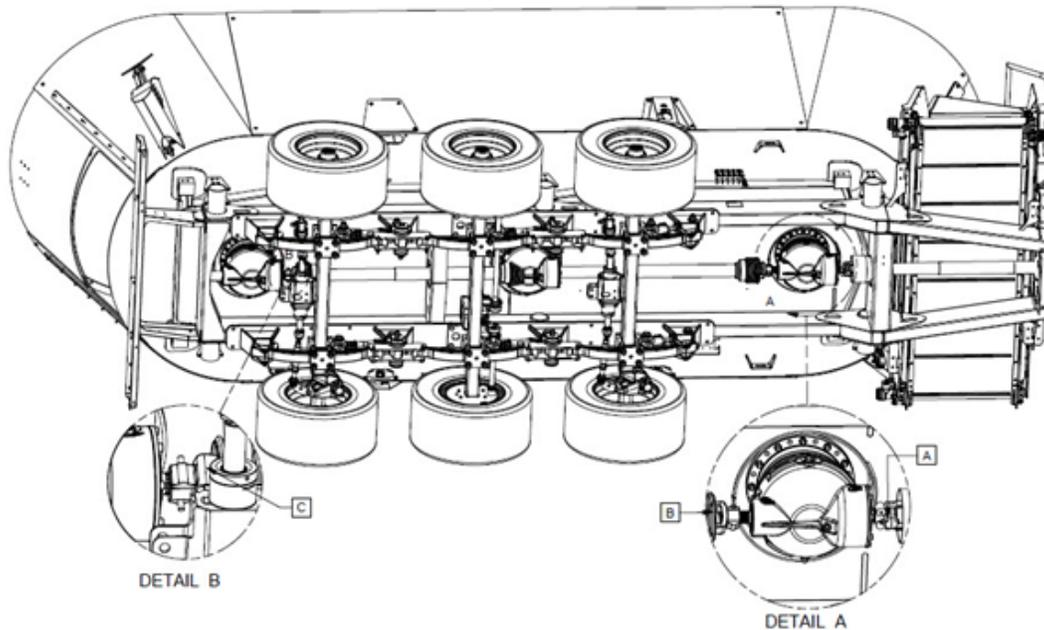

Figure 40 — Location of the Shear Bolt Yokes on a Triple-Auger SMARTMIX

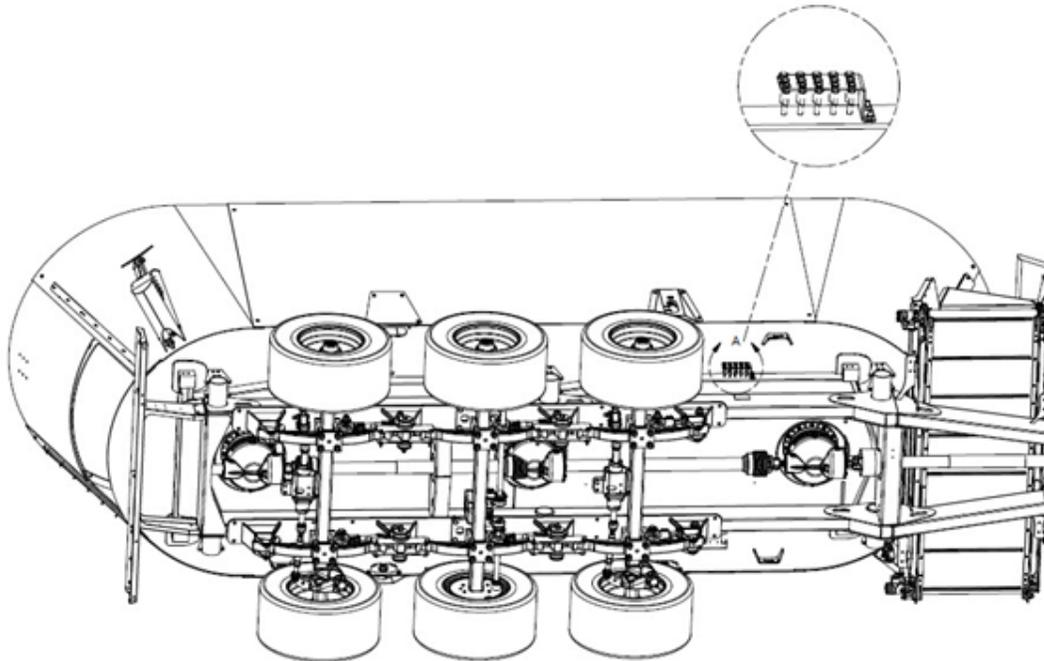

Figure 41 — Location of the Shear Bolts on the A950 and A1230 SMARTMIX

 Important!	<p>After emptying the machine, check the indexation of the mixing augers (their positions in relation to each other). The front auger scraper (Figure 42, D) and middle auger scraper (Figure 42, E) must be offset from each other by 90°. The middle auger scraper (Figure 42, E) and rear auger scraper (Figure 42, F) must also be offset from each other by 90°.</p>
--	--

To synchronize the mixing augers:

1. Disconnect the drive shaft from the middle auger.
2. Using the tractor PTO, rotate the front auger into Position D and the middle auger into Position E.
3. Once the first two augers are synchronized, reconnect the drive shaft to the middle auger.
4. Disconnect the drive shaft from the rear auger.
5. Using the tractor PTO, rotate the rear auger into Position F.
6. Once the augers are synchronized, reconnect the drive shaft to the rear auger.

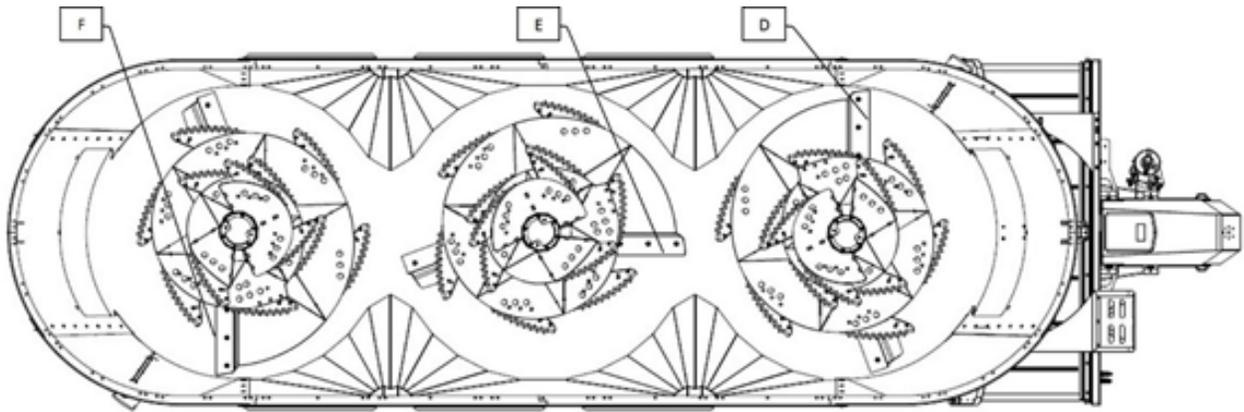

Figure 42 — Synchronizing the Mixing Augers (Three Augers)

7 Maintenance



Warning!

Only qualified and trained individuals are authorized to perform maintenance.



Warning!

See "Safety tips for maintenance and repairs" on page 53 before beginning maintenance.

The user is responsible for machine maintenance. Carefully follow the instructions below for optimal durability and smooth performance.

- For drive shaft and tractor maintenance, see the corresponding instruction manuals.
- Always keep the machine and its accessories clean and in perfect condition.
- Let the transmission components (drive shaft, gearbox, belts, hoses and other hydraulic components, etc.) cool down before beginning work.
- Follow the recommended maintenance intervals.



Warning!

Before proceeding with any repairs, maintenance or cleaning, turn off the tractor engine, remove the key from the ignition and disconnect the drive shaft from the PTO.

Never perform maintenance while the machine is running.



Important!

Dispose of used oil and filters in accordance with current standards.

To extend the machine's lifespan, avoid leaving any silage or corrosive products in the mixing chamber for long periods of time.



ANDERSON

 Warning!	<p>Avoid entering the mixing chamber to clean it, as you could fall and cut yourself on the knives. Use appropriate cleaning tools, such as a pitchfork, broom or pressure washer.</p> <p>If you must enter the mixing chamber, wear non-slip shoes, gloves, coveralls, etc. and cover the knife edges.</p>
---------------------	---

 Warning!	<p>If entering the mixing chamber through a hydraulic hatch, close the safety valve to prevent the hatch from closing.</p>
---------------------	---

7.1 Maintenance schedule

The following table summarizes the maintenance tasks and their required intervals, which will be covered in the following sections.

Table 10 — Maintenance Schedule

Operation	Daily	First use	After the first (hours)			Every (hours)			Annually or every 2,000 hours (whichever comes first)	See Section
			10	50	100	50	100	200		
Grease the universal joints (drive shaft)						X				"Greasing" on page 108
Grease the drive shaft sliding sleeves						X				"Greasing" on page 108
Grease the gearbox on the upper part of the planetaries							X			"Greasing" on page 108
Grease the bearings						X				"Greasing" on page 108
Grease the cylinder joints								X		"Greasing" on page 108



ANDERSON

Operation	Daily	First use	After the first (hours)			Every (hours)			Annually or every 2,000 hours (whichever comes first)	See Section
			10	50	100	50	100	200		
Grease the walking beam tandems								X		"Greasing" on page 108
Grease the hatch rails								X		"Greasing" on page 108
Grease the manual jack (A280, A380 and A520)								X		"Maintaining the jacks" on page 127
Check the planetary oil level	X									"Checking the planetary oil level and changing the oil" on page 115
Change the planetary oil					X				X	"Checking the planetary oil level and changing the oil" on page 115
Perform maintenance on the planetary oil tank cap	X							X		"Performing maintenance on the planetary oil tank cap" on page 120
Check the two-speed gearbox oil level						X				"Checking the gearbox oil level and changing the oil" on page 118



ANDERSON

Operation	Daily	First use	After the first (hours)			Every (hours)			Annually or every 2,000 hours (whichever comes first)	See Section
			10	50	100	50	100	200		
Change the two-speed gearbox oil					X				X	"Checking the gearbox oil level and changing the oil" on page 118
Check the tire pressure		X					X			"Checking the tires" on page 114
Check the wheel nut tightness			X	X	X				X	"Checking the tires" on page 114
Tighten bolts				X					X	"Tightening torque" on page 128
Power wash the inside of the conveyors								X		"Cleaning" on page 130
Power wash the inside and outside of the machines								X		"Cleaning" on page 130
Check and sharpen or replace visibly worn knives (varies based on rations)							X			"Sharpening or replacing the knives" on page 120
Check the conveyor belt tension								X		"Checking and adjusting the conveyor tension" on page 123

Operation	Daily	First use	After the first (hours)			Every (hours)			Annually or every 2,000 hours (whichever comes first)	See Section
			10	50	100	50	100	200		
Check and adjust the scrapers								X		"Checking and adjusting the scrapers" on page 126
Clean the inside of the mixing augers							X			"Greasing the planetaries and the inside of the mixing augers" on page 110
Perform maintenance on the tridem axle (option)	See the ADR manual provided with the mixer.									



ANDERSON

7.2 Greasing

7.2.1 Greasing points

Your SMARTMIX must be greased using a gun where indicated by the sticker in the following figure:



Figure 43 — Greasing Point Marker

NOTE: Anderson Group recommends using NLGI Type 2 synthetic lithium grease.

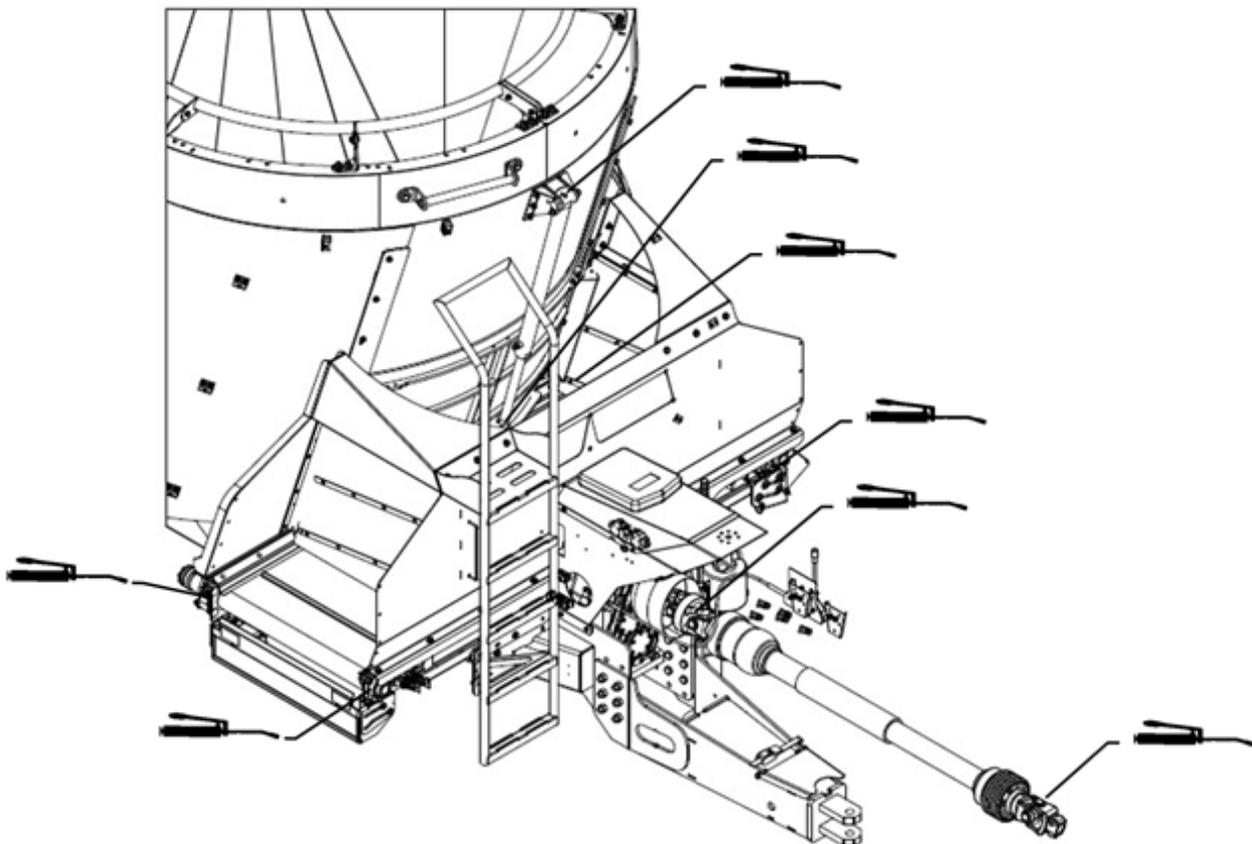

Figure 44 — Greasing Points (1)

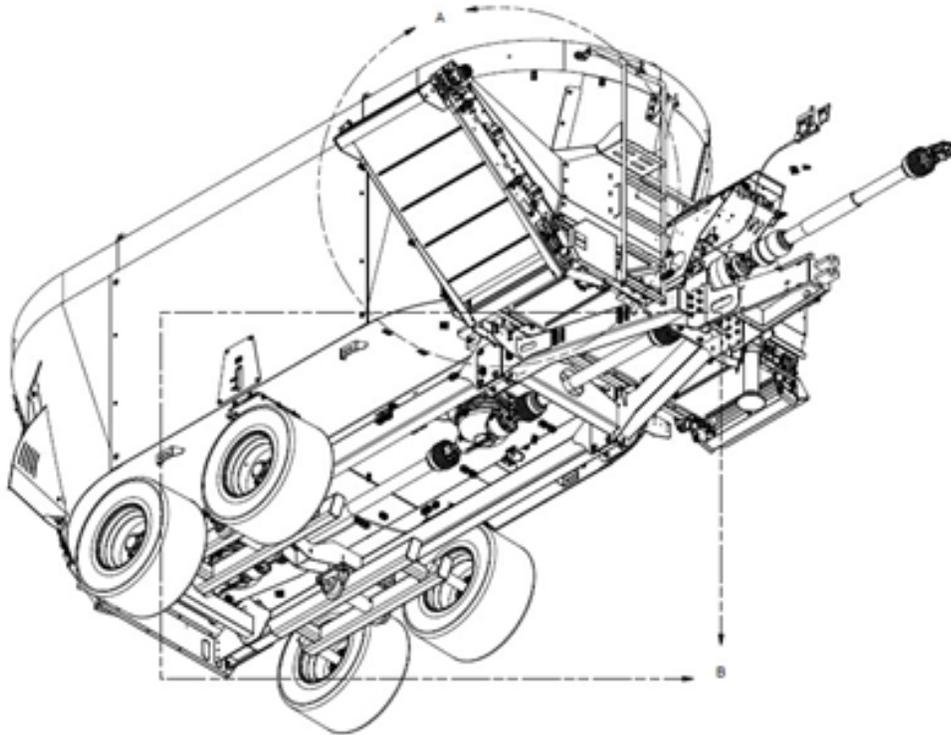

Figure 45 — Greasing Points (2)

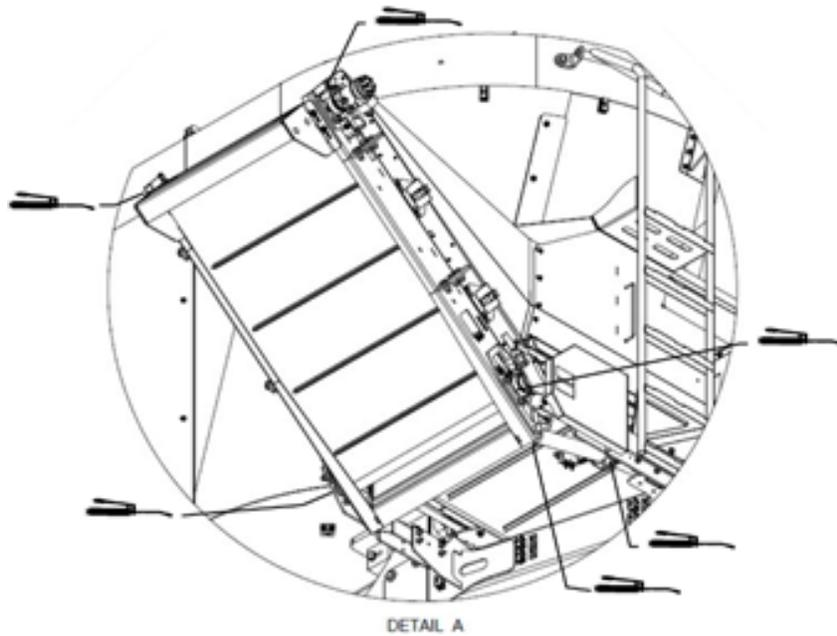

Figure 46 — View of Detail A in the Greasing Points (2) Figure

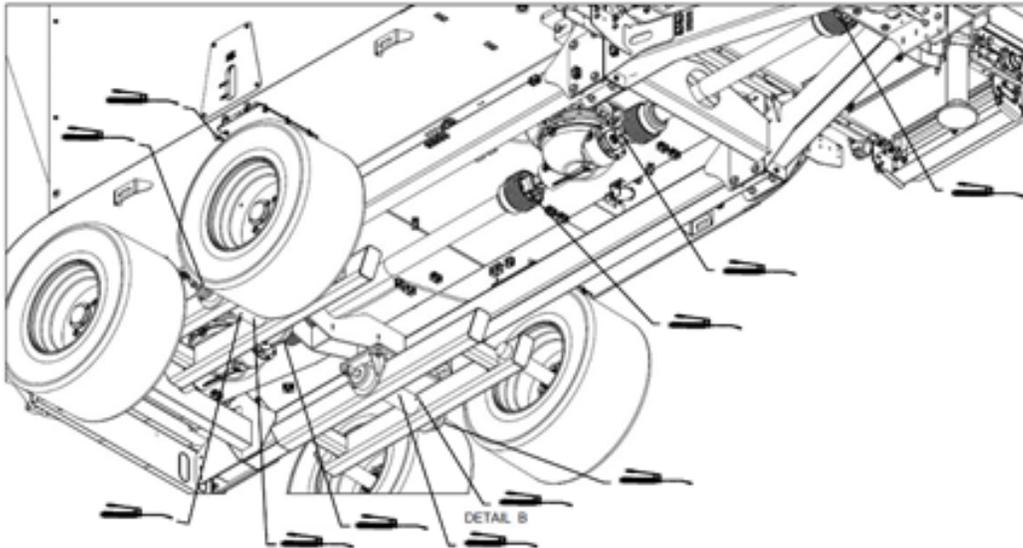

Figure 47 — View of Detail B in the Greasing Points (2) Figure

7.2.2 Greasing the planetaries and the inside of the mixing augers

Grease the planetaries after every 100 hours of use with NLG1 Type 2 synthetic lithium grease:

1. Remove the access hatch (Figure 48, A) and take the opportunity to clean the inside of the mixing auger.
2. Locate the greasing port underneath the oil tank (Figure 48, B).
3. Grease the planetary until grease comes out the overflow hole (Figure 48, C).
4. Turn the auger manually to distribute the grease inside the planetary, and then repeat step 3.

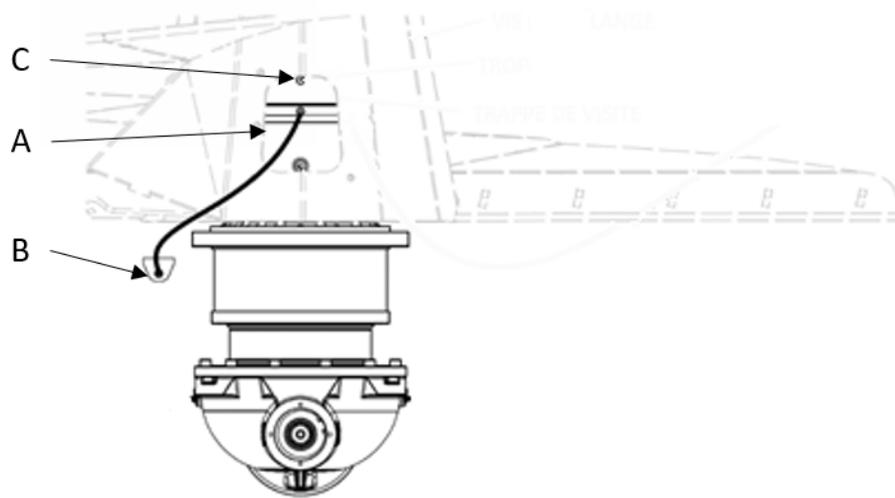

Figure 48 — Greasing the Planetaries



Warning!

Before entering the mixing chamber, unhitch the tractor from the machine to prevent it from starting accidentally.

Use safe and stable means of access and ensure that the mixing augers and the inside of the mixing chamber are clean.

Wear protective equipment (gloves, goggles, etc.) and use appropriate tools.

7.2.3 Greasing the drive shafts

The drive shaft (optional) that is connected to the tractor is the primary drive shaft. The other shafts, which are beneath the machine, are secondary, tertiary, etc. The primary drive shaft has extended lubrication crosses, while the other shafts have standard crosses. A grease fitting is located at one end of the crosses, regardless of whether the crosses are standard or extended lubrication.



Figure 49 — Standard Cross



Figure 50 — Extended Lubrication Cross



Warning!

Follow all the safety guidelines in Chapter "Safety precautions" on page 47 when working near and greasing the drive shafts.

The points on the drive shafts shown in the following illustrations must be greased at the recommended intervals and after long periods of inactivity. Improper greasing of the drive shafts may decrease the lifespan of their components.



Warning!

Always stop the tractor PTO and ensure that all rotating parts have stopped before approaching and greasing the drive shafts.

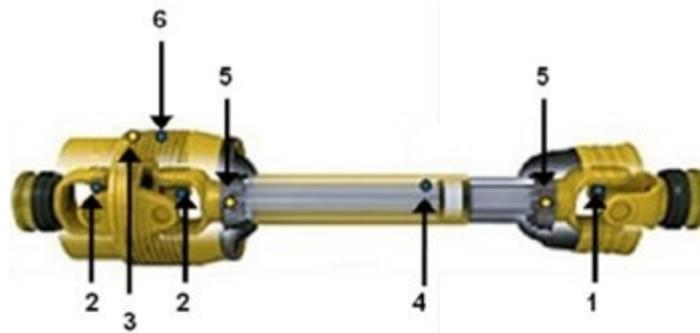

Figure 51 — Primary Drive Shaft Greasing Points



Figure 52 — Secondary Drive Shaft Greasing Points

The following table shows the recommended greasing intervals for each drive shaft component.

Table 11 — Frequency for Greasing the Drive Shaft Components

No. (Figure 51 and Figure 52)	Component	Interval
1	Crosses	50 hrs
2	Crosses	50 hrs
3	Constant velocity joints (double cardan)	50 hrs
4	Sliding tubes	50 hrs
5	Cardan and tube guard	50 hrs
6	Constant velocity joint guards	50 hrs



ANDERSON

 **Important!** When greasing the drive shafts, ensure that they are properly attached to the tractor and gearboxes and that their guards are in good working condition. Immediately replace them if damaged.

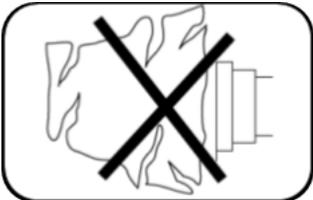
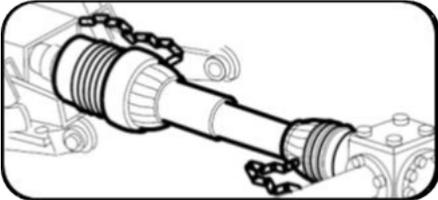

Carefully read the Comer Industries drive shaft manuals attached to each drive shaft. These manuals contain important information about regulations for using the PTO shafts. If your manuals have been lost or damaged, contact your Anderson dealer for new ones.

7.3 Checking the tires

Model	Tire designation	Nominal inflation pressure	Wheel torque
A280 SMARTMIX	15.0/55-17 26 PLY	7.1 bar (103 psi)	270– 290 N m
A380 and A450 SMARTMIX	15.0/55-17 26 PLY	7.1 bar (103 psi)	270– 290 N m
A520 SMARTMIX	385/65R22.5	8.9 bar (130 psi)	270– 290 N m
A700 SMARTMIX	275/701R22.5 double (standard) 445/45R19.5 (option)	9 bar (130 psi)	270– 290 N m
A920 SMARTMIX	445/45R19.5	9 bar (130 psi)	270– 290 N m
A950 and A1230 SMARTMIX	275/701R22.5 double (standard) 445/45R19.5 (option)	9 bar (130 psi)	350– 380 N m

7.4 Checking the planetary oil level and changing the oil

NOTE: Check the oil level when the machine is stopped and the oil temperature is between 20° C and 30° C.

On the SMARTMIX A280, A380 and A450 models, the planetary oil tank(s) are on the front left of the mixing chamber, beside the ladder.

On the SMARTMIX A520, A700, A920, A950 and A1230 models, the oil tanks are on each side of the mixing chamber.

The arrows above and below the OIL indicator show whether it is for the front or rear gearbox.

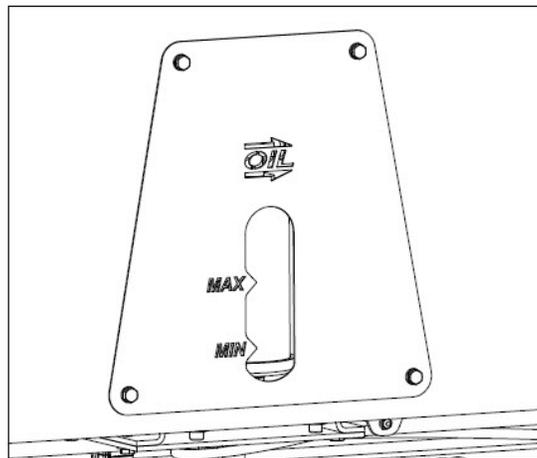

Figure 53 — Planetary Oil Level Indicator

To adjust the oil level by adding oil:

1. Remove the oil tank cap (Figure 54).
2. Pour in oil until the oil level in the tank is between the minimum and maximum fill lines (see Table 14 in "Appendix A — SMARTMIX maintenance summary tables" on page 132 for the recommended type of oil).
3. Put the oil tank cap back on.

To adjust the oil level by removing oil:

1. Remove the drain plug that is all the way underneath the planetary (Figure 54). The oil will drain out. Collect it in a container.
2. When the oil level in the tank is between the minimum and maximum fill lines, put the planetary drain plug back in.

To perform a full oil change:



ANDERSON

NOTE: Draining the gearbox is easier when the oil temperature is between 20° C and 30° C.

1. Unscrew the drain plug on the hydraulic T fitting under the mixer (Figure 54). This prevents excess pressure from building up inside the planetary as it fills.
2. Make sure that the oil has completely stopped flowing.



Do not put the plug back in until step 9.

3. Remove the drain plug underneath the planetary and collect the oil in a container.
4. Remove the steel particles that the plug magnet collected.
5. Apply new Teflon tape to the plug threads to ensure that it will form a tight seal.
6. Once the planetary is completely empty, put the drain plug back in the planetary.
7. Unscrew the hydraulic hose under the tank and connect a properly calibrated pump (Figure 54). Adjust the pump so that its flow and pressure are very low to avoid creating excess pressure inside the planetary.



Excess pressure could severely damage the seals inside the planetary.

8. Pump oil into the planetary until oil comes out the hydraulic T fitting under the mixer.
9. Put the plug back in the hydraulic T fitting.
10. Reconnect the hydraulic hose under the tank and finish filling it by pouring oil directly into the tank until the level is between the minimum and maximum fill lines (see Table 14 in "Appendix A — SMARTMIX maintenance summary tables" on page 132 for the quantity and type of oil for your mixer).
11. For mixers with a 3002 planetary model, change the oil in the T-301B gearbox, which is located all the way at the bottom of the planetary (see Table 14 in "Appendix A — SMARTMIX maintenance summary tables" on page 132 for the quantity and type of oil for your mixer).

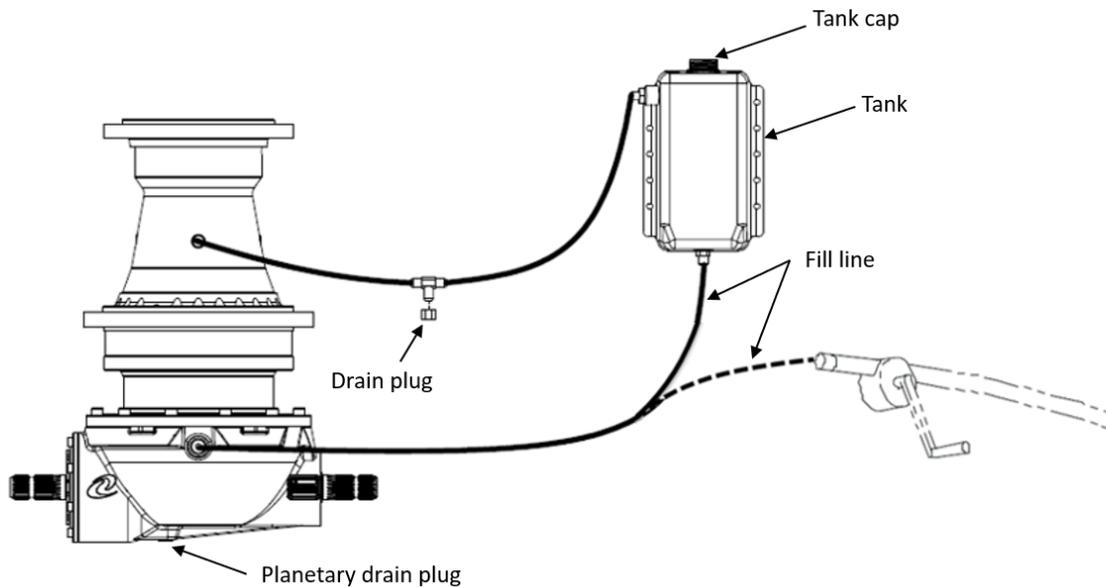

Figure 54 — Oil Tank



Make sure that you never create excess pressure inside the planetary by introducing air or oil, as this could severely damage the seals. During filling, remove the cap so that air can flow freely out of the planetary.



To prevent overflowing, the oil must never exceed the maximum level in the tank.



ANDERSON



Important!

The first oil change must be done after the first 100 hours of use. Subsequent oil changes must be done after every 2,000 hours of use or annually, whichever comes first.

The required type and quantity of oil are detailed in Table 14 in "Appendix A — SMARTMIX maintenance summary tables" on page 132 at the end of the manual.

Failure to follow the maintenance intervals or use the correct type and quantity of oil will void the warranty!

For the warranty to apply, you must keep proof of maintenance.

NOTE: The used oil must be collected in a clean, leak-proof container designated for this purpose, and then dropped off at a specialized recycling centre.

7.5 Checking the gearbox oil level and changing the oil

The gearbox oil level is good if the oil reaches the cap in the middle of the gearbox (Figure 55, B).

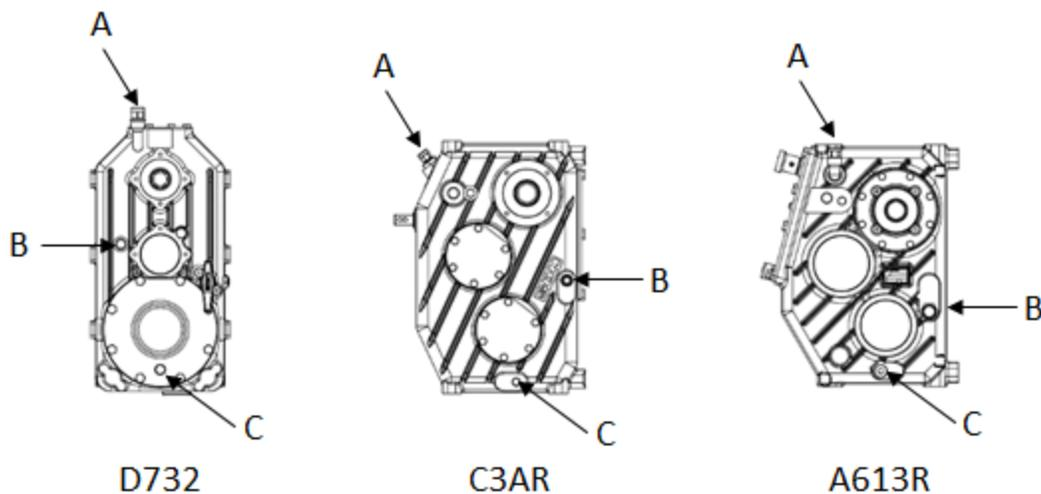

Figure 55 — D732 (A), C3AR (B) and A613R (C) Speed Reducers

To top up the oil:

1. Remove the drive shaft and the protective guard at the front of the gearbox.
2. Unscrew the plugs (Figure 55, A and B).

3. Pour oil into the opening (Figure 55, A) until it comes out the hole (Figure 55, B).

To perform a full oil change:

NOTE: Draining the gearbox is easier when the oil temperature is between 20° C and 30° C.

1. Remove the drive shaft and the protective guard at the front of the gearbox.
2. Unscrew the breather (A) and the fill plug (B) to create airflow.
3. Remove any dirt from the breather and clean it with a mild detergent.
4. Unscrew the drain plug (C) and collect the oil in a container.



Important!

Remove any steel particles on the plug that were collected by the magnet.

5. Apply new Teflon tape and put the drain plug (C) back in.
6. Pour oil into the fill port (A) until it comes out the fill plug (B).



Important!

The first oil change must be done after the first 100 hours of use. Subsequent oil changes must be done after every 2,000 hours of use or annually, whichever comes first. The required type and approximate quantity of oil are detailed in Table 15 — Oil for the Speed Reducers in "Appendix A — SMARTMIX maintenance summary tables" on page 132. Failure to follow the maintenance intervals or use the required type and quantity of oil will void the warranty! For the warranty to apply, you must keep proof of maintenance.



ANDERSON

7.6 Performing maintenance on the planetary oil tank cap

The oil tank for each planetary has a cap on top to vent the system's internal pressure. Always keep the cap clean and clear of contaminants and debris.

To keep the cap in good condition:

- Visually inspect the oil tank cap daily and remove anything that may have fallen on top.
- Clean the cap after every 200 hours of use, twice annually, or each time the lubrication system leaks. To do so:
 1. Remove the cap.
 2. Remove any debris from the cap and clean it with a mild detergent.
 3. Put the cap back on the oil tank.

7.7 Sharpening or replacing the knives

If the knives are losing effectiveness:

1. When the teeth start wearing down, swap the lower and upper knives.
2. When the teeth on all the knives are worn down, turn all the knives over so that the tungsten coating is on top (Figure 56).
3. When the knives lose their edge again, take them apart and grind the teeth to restore their edge. Reinstall the knives and put the sharpest ones in the bottom of the mixing auger.
4. Replace all the knives when cutting is no longer satisfactory.

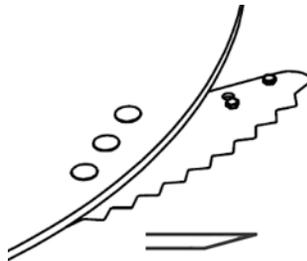

Figure 56 — Knives Turned Over, With the Tungsten Coating on Top



Warning!

Before entering the mixing chamber, unhitch the tractor from the machine to prevent it from starting accidentally.

Use safe and stable means of access and ensure that the mixing augers and the inside of the mixing chamber are clean.

Wear protective equipment (gloves, goggles, etc.) and use appropriate tools.

7.8 Adjusting or replacing the auger scrapers

If the scrapers (Figure 57, A) lose some of their effectiveness, you can start by readjusting them. If that does not solve the problem or you reach the end of the adjustment slots, replace them.

To adjust the auger scrapers:

1. Place the scraper in the highest part of the bottom of the mixing chamber.
2. Loosen the bolts, ensuring that they do not fall under the auger and get lost.
3. If replacing the scraper, remove the scraper and put the new one in the same spot.
4. Adjust the bottom of the scraper so that it is at least 3 mm (1/8 in.) from the bottom of the mixing chamber.

NOTE: If there is not enough clearance (3 mm or more), the scraper may get stuck at the bottom of the mixing chamber when it is under a load.

5. Repeat these steps to replace the second scraper.

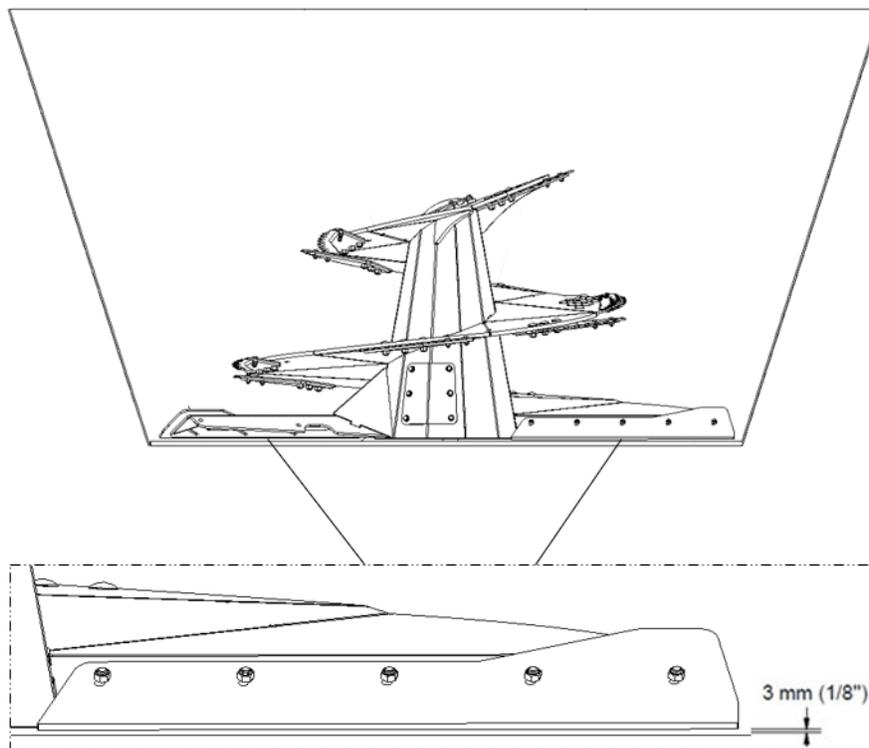

Figure 57 — Adjusting the Scrapers



ANDERSON



Warning!

Before entering the mixing chamber, unhitch the tractor from the machine to prevent it from starting accidentally.

Use safe and stable means of access and ensure that the mixing augers and the inside of the mixing chamber are clean.

Wear protective equipment (gloves, goggles, etc.) and use appropriate tools.

7.9 Checking and adjusting the conveyor tension

7.9.1 SMARTMIX with horizontal conveyor

Ensure that there is 25 to 35 mm (1 to 1 3/8 in.) (Figure 58) of clearance between the conveyor belt and chassis. If not, adjust the tension (see "Adjusting the conveyor belt tension" on page 125).

NOTE: The measurement must be taken in the centre of the conveyor.

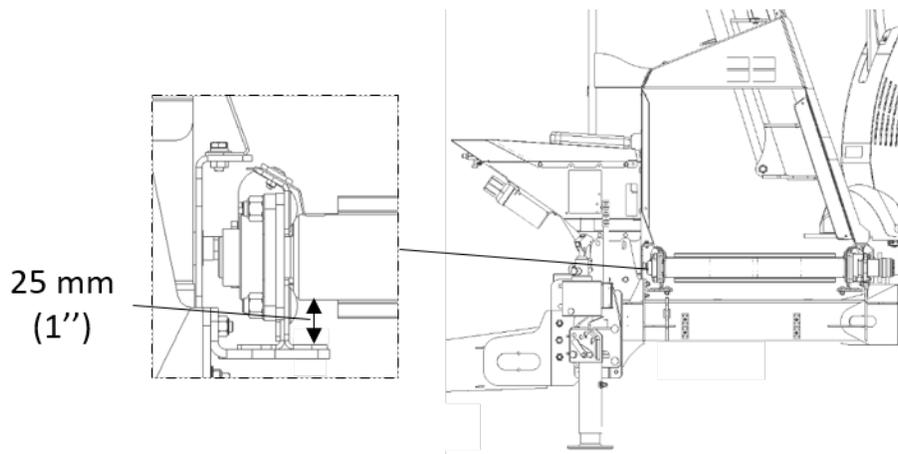

Figure 58 — Clearance Between the Conveyor Belt and Frame for the SMARTMIX with Horizontal Conveyor



ANDERSON

7.9.2 SMARTMIX with horizontal and inclined conveyors

Ensure that there is 25 to 35 mm (1 to 1 3/8 in.) (Figure 59) of clearance between the conveyor belt and frame. If not, adjust the tension (see "Adjusting the conveyor belt tension" on page 125).

NOTE: The measurement must be taken in the centre of the conveyor.

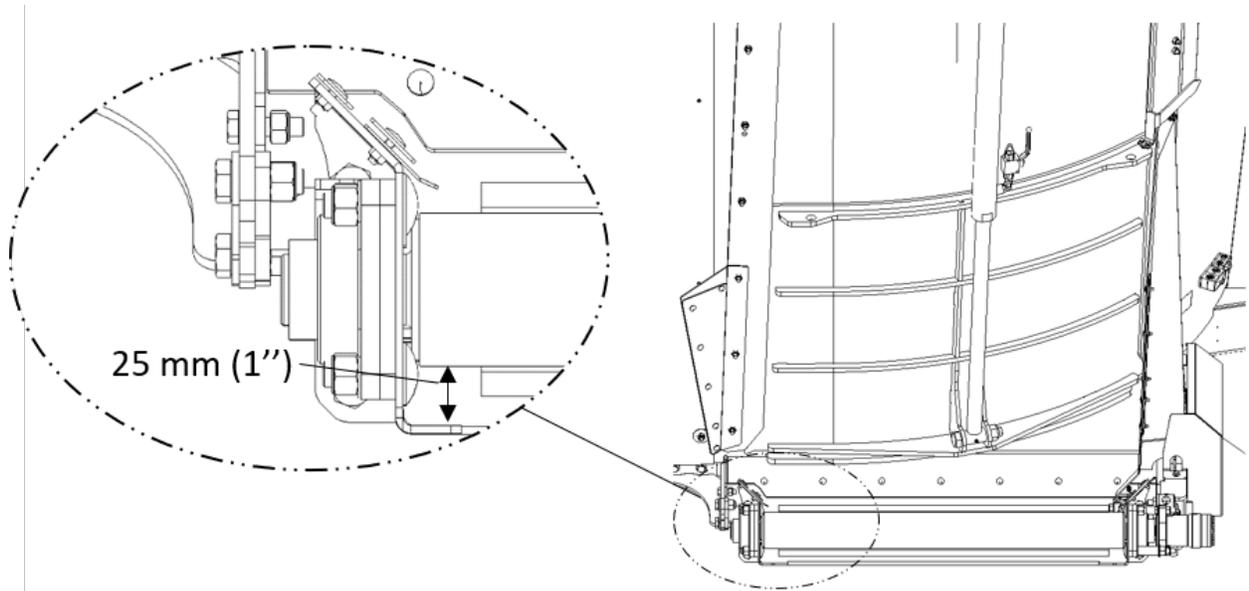

Figure 59 — Clearance Between the Conveyor Belt and Frame for the SMARTMIX with Horizontal and Inclined Conveyors

7.9.3 Adjusting the conveyor belt tension

 <p>Warning!</p>	<p>This must be done on each side of the conveyor. Stop the conveyor before proceeding.</p>
---	--

To adjust the clearance between the conveyor belt and frame:

1. Loosen the ball bearing nuts (Figure 60, 2).
2. Adjust the tension by tightening or loosening the adjusting nuts (Figure 60, 1).
3. Tighten the ball bearing nuts (Figure 60, 2).

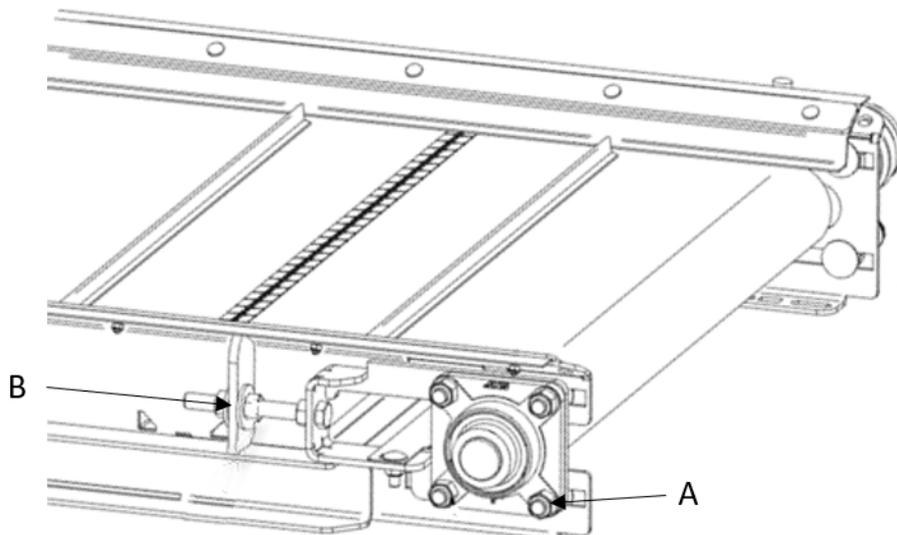

Figure 60 — Adjusting the Horizontal or Inclined Conveyor Belt Tension



ANDERSON

7.10 Checking and adjusting the scrapers



**This must be done on each side of the conveyor.
Stop the conveyor before proceeding.**

Ensure that there is 3 mm (1/8 in.) of clearance between the scraper and the roller (Figure 62, B). If not, adjust the scraper.

To adjust the clearance between the scraper and roller:

1. Loosen the bolts on each side of the conveyor (Figure 61, A).
2. Adjust the distance between the scraper and roller.
3. Tighten the bolts (Figure 61, A).

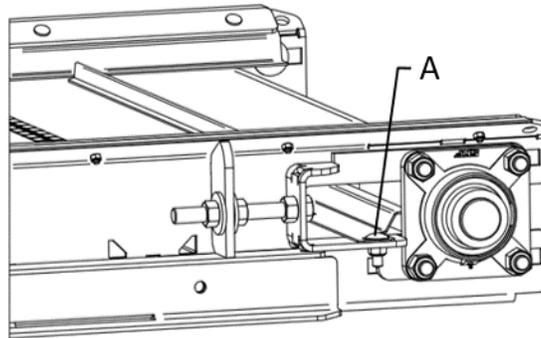

Figure 61 — Adjusting the Conveyor Scraper

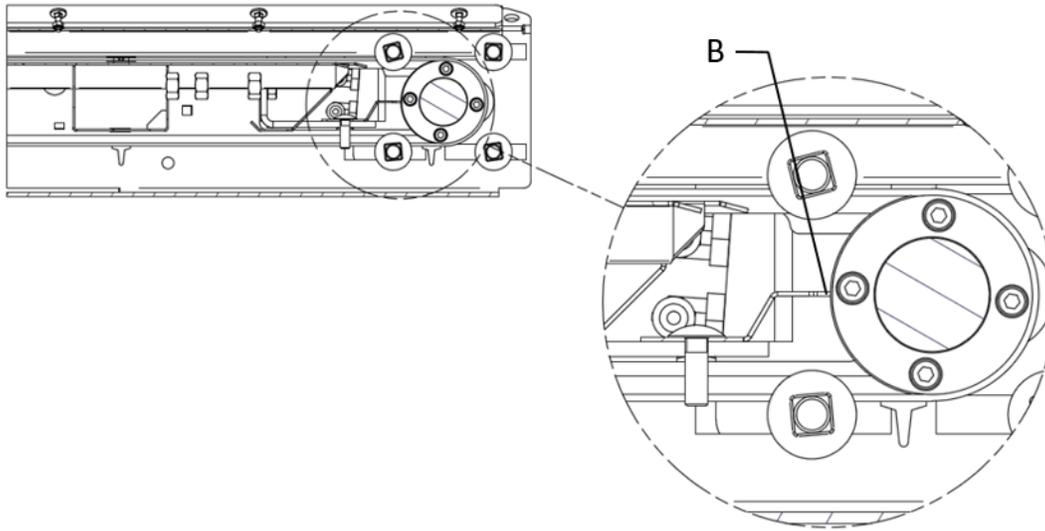

Figure 62 — Clearance Between the Pulley and Scraper

7.11 Maintaining the jacks

Your mixer has either a manual jack or a hydraulic jack.

Manual jack: Grease the mechanism (Figure 63, A) every 200 hours. See Table 16 in "Appendix A — SMARTMIX maintenance summary tables" on page 132 for the quantity and type of oil to use.

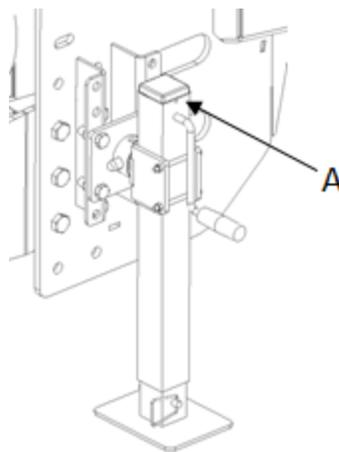

Figure 63 — Mechanism on the Manual Jack

Hydraulic jack: No maintenance is required



ANDERSON

7.12 Tightening torque

Table 12 — Imperial Bolt Tightening Torque

Diameter (in.)	0.25	0.3125	0.375	0.4375	0.5	0.5625	0.625	0.75	0.875	1
	1/4	5/16	3/8	7/16	1/2	9/16	5/8	3/4	7/8	1
Threads per inch (NC)	20	18	16	14	13	12	11	10	9	8
Tightening torque in ft./lb. (multiply by 1,356 for N m)										
SAE 2	5.5	11	20	32	50	70	100	175	170	250
SAE 5	8	17	30	50	75	110	150	260	430	640
SAE 8	12	24	45	70	110	150	210	380	600	910

Diameter (in.)	0.25	0.3125	0.375	0.4375	0.5	0.5625	0.625	0.75	0.875	1
	1/4	5/16	3/8	7/16	1/2	9/16	5/8	3/4	7/8	1
Threads per inch (NF)	28	24	24	20	20	18	18	16	14	14
Tightening torque in ft./lb. (multiply by 1,356 for N m)										
SAE 2	6.3	12	23	36	55	80	110	200	180	280
SAE 5	10	19	35	55	85	120	170	300	470	720
SAE 8	14	27	50	80	120	170	240	420	670	1,020

Table 13 — Metric Bolt Tightening Torque

Diameter (mm)	6	8	10	12	14	16	18	20	22	24
	M6	M8	M10	M12	M14	M16	M18	M20	M22	M24
Pitch (mm)	1	1.25	1.5	1.75	2	2	2.5	2.5	2.5	3
Tightening torque in N m										
CLASS 4.6	5	11	22	39	62	96	133	188	256	325
CLASS 8.8	12	30	59	104	165	257	355	501	683	866
CLASS 10.9	18	44	87	152	243	377	521	736	1,004	1,272
CLASS 12.9	21	52	102	178	284	441	610	862	1,175	1,489



ANDERSON

Diameter (mm)	6	8	10	12	14	16	18	20	22	24
	M6	M8	M10	M12	M14	M16	M18	M20	M22	M24
Pitch (mm)	0.75	1	1	1.25	1.5	1.5	1.5	1.5	1.5	1.5
Tightening torque in N m										
CLASS 4.6	5	12	25	42	67	103	149	209	281	369
CLASS 8.8	14	32	66	113	179	274	399	556	750	985
CLASS 10.9	20	47	97	166	262	402	585	817	1,102	1,447
CLASS 12.9	23	55	112	194	307	471	685	956	1,290	1,693



ANDERSON

7.13 Cleaning

Before storing the machine, thoroughly clean and grease it.

Any build-up that accumulates during work can make your machine rust more quickly. Regularly remove it with a power washer at the intervals specified in "Maintenance schedule" on page 104.

7.13.1 Personal protective equipment

When cleaning the machine, especially with a pressure washer lance, wear personal protective equipment (gloves, goggles, etc.) to protect yourself from the spray.

7.13.2 Basic cleaning method

Cover all openings that need to be protected from water, steam or cleaning products.

If using a pressure washer lance, avoid holding it too close to the machine or directing the spray towards hydraulic components, joints, fill caps, electrical connections, safety labels, etc.

7.13.3 Cleaning method for inside the conveyor belts

After the mixer has been used for a while, material tends to build up between the conveyor belt and chassis.

Openings are provided to pass the lance inside the conveyor and clean the belt more easily.

To thoroughly clean the inside of the belt:

1. Start the conveyor belt.
2. Using the provided openings (see Figure 64), direct the spray directly onto the conveyor pulleys. The excess water and dirt should come out the other side of the conveyor.
3. Stop once all the dirt has been washed away.

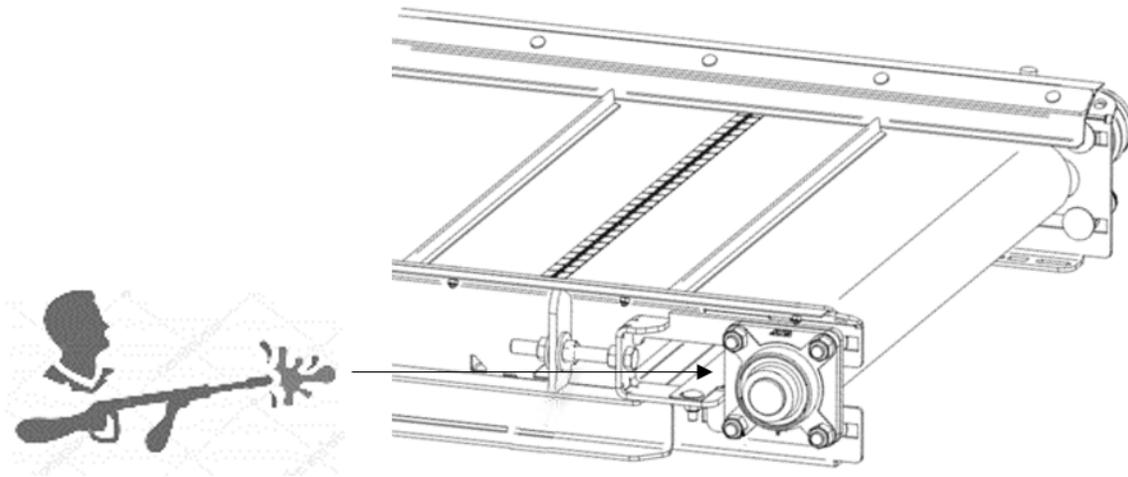

Figure 64 — Openings Provided for Cleaning the Conveyor

7.13.4 Cleaning products

Do not use harsh (chlorinated) cleaning products.

Use lint-free rags or soft brushes.

7.13.5 Post-cleaning inspection

After cleaning, check the hydraulic hoses for leaks or damage and ensure that the couplings are tight.

Immediately repair any damage.

Check that all the bolts are tight.

7.14 Storage

For extended storage:

- Clean the machine (see "Cleaning" on page 130).
- Store the machine with all the hatches open approximately 5 cm (2 in.). Place it on a stable surface, slightly inclined toward the front hatch, to prevent water from sitting in the mixing chamber.
- Before putting the machine in storage, grease the cylinder rods. Before using it again, clean the rods with a diesel-soaked rag and wipe them with a clean, dry cloth.
- Grease the joints ("Greasing points" on page 108).
- Place all the hydraulic hose connections on their respective supports.



ANDERSON

Appendix A — SMARTMIX maintenance summary tables

Table 14 — Oil for the Planetaries

Model	Planetary	Oil		
		Type	Litres	US gal.
A280	PGA 1602	ISO 220 synthetic industrial gear oil (e.g. Castrol Isolube EP 220, Shell Omala S4 GX 220, Mobil SHC 630)	22.5	5.9
A380	PGA 1602		22.5	5.9
A450	PGA 1602		22.5	5.9
A520	PGA 1602		22.5	5.9
A700	PGA 1602		22.5	5.9
	PGA 1603		25.0	6.6
	PGA 2103		27.5	7.3
A920	PGA 2103		27.5	7.3
	PGA 3002		20.0	5.3
	T-301B		4.4	1.2
A950	PGA 2102		24.0	6.3
A1230	PGA 2102		24.0	6.3
	PGA 3002		20.0	5.3
	T-301B		4.4	1.2

Table 15 — Oil for the Speed Reducers

Speed reducer	Oil		
	Type	Litres	US gal.
D732	ISO 220 synthetic industrial gear oil (e.g. Castrol Isolube EP 220, Shell Omala S4 GX 220, Mobil SHC 630)	5	1.3
C3AR		8.5	2.2
A613R		9	2.4
A614R		25	6.6

Table 16 — Oil for the Other Components

Component	Oil		
	Type	Litres	US gal.
Hydraulic jack	Dexron III Automatic Transmission Fluid	5	1.3

Component	Oil		
	Type	Litres	US gal.
Other	NLGI Type 2 synthetic lithium grease (e.g. Mobil SHC 460, Shell Gadus S5 V100 2)	As required	

Table 17 — Power Take-Off (PTO) Shear Bolts

Model	Planetary	Second PTO	Third PTO	Fourth PTO
A280	PGA 1602	M10X60 CL 8.8	-	-
A380	PGA 1602	M10X60 CL 8.8	-	-
A450	PGA 1602	M10X60 CL 8.8	-	-
A520	PGA 1602	M12X65 CL 10.9	M10X60 CL 8.8	-
A700	PGA 1602	M14X70 CL 8.8 ¹	M10X60 CL 8.8	-
	PGA 1603	M10X60 CL 8.8 ²	M10X60 CL 6.6	-
	PGA 2103	M10X60 CL 10.9	M10X60 CL 6.6	-
A920	PGA 2103	M10X60 CL 10.9	M10X60 CL 6.6	-
	PGA 3002	M12X65 CL 6.6	M8X60 CL 8.8	-
	T-301B			
A950	PGA 2102	M12X90 CL 8.8	M14X70 CL 8.8	M10X50 CL 8.8
A1230	PGA 2102	M12X90 CL 8.8	M14X70 CL 8.8	M10X50 CL 8.8
	PGA 3002	M14X70 CL 8.8	M10X60 CL 8.8	M8X60 CL 8.8
	T-301B			

¹ M12X65 CL 10.9 for pre-2020 models.

² M12x65 CL 6.6 for pre-2019 models.

Table 18 — Tire Specifications

Model	Designation	Pressure	Tightening torque
A280	15.0/55R17 26 PLY	7.1 bar (103 psi)	270–290 N m
A380	15.0/55R17 26 PLY	7.1 bar (103 psi)	270–290 N m
A450	15.0/55R17 26 PLY	7.1 bar (103 psi)	270–290 N m
A520	385/65R22.5 20 PLY	9 bar (130 psi)	270–290 N m
A700	275/70R22.5 (double)	9 bar (130 psi)	270–290 N m
	445/45R19.5 (optional)		



ANDERSON

Model	Designation	Pressure	Tightening torque
A920	445/45R19.5	9 bar (130 psi)	270–290 N m
A950	275/70R22.5 (double) 445/45R19.5 (optional)	9 bar (130 psi)	350–380 N m
A1230	275/70R22.5 (double) 445/45R19.5 (optional)	9 bar (130 psi)	350–380 N m



ANDERSON GROUP

5125 De la Plaisance St.
Chesterville, QC G0P 1J0
CANADA

Email: support@grpanderson.com

Phone: 1-819-382-2952

Fax: 1-819-382-2218

grpanderson.com