

Round Bale Wrapper
RB 580



ANDERSON



For safe and proper functioning please:

- 1.** Read the manual.
- 2.** Follow the safety instructions.
- 3.** Follow the start-up steps given on the last page of your manual.
- 4.** In case of sale or transfer, give this manual to the new owner.

The illustrations in this manual are presented for your reference according to the latest information available at the moment of printing. ANDERSSON EQUIPMENT reserves the right to modify its machines without advance notice.

Table of Contents

1	Anderson limited warranty	5
2	Safety	8
3	Safe Operators	8
4	Adjustment Procedures	12
5	Operating Procedures	14
5.1	Moving the Bale Wrapper	15
5.2	Using the IG-C3 Bale Counter	15
5.3	Start and End Wrapping	16
5.4	Bale Wrapping: Adjusting the Sensors	17
5.5	Adjusting the Mechanical Plastic Film Cutter	18
6	Maintenance Procedures	20
6.1	Maintenance	20
6.2	Grease Gun Lubrication	20
6.3	Other Lubrication Points	24
6.4	Cleaning and Other Maintenance	25
6.5	Storage	26
7	Troubleshooting: Problems and Solutions	27
8	Optional Equipment	29
8.1	Hydraulic Unit	29
8.2	Electric starter with 18 amp. alternator and work light	29
8.3	Stabilizers	30
8.4	Modifying Gears to Reduce Stretch Ratio	30
8.5	Bale Loading Arm and Plastic Film Roll Support	30
8.6	Bale Unloading Platform (D)	31
8.7	Unloading Platform (D3)	32
8.8	Double Roll Plastic Unit	36
9	Start-Up Procedures	37

How to Reach Us

- When you contact us, always provide us with the following information:
- Your name, address, and telephone number;
 - Product model and serial number;
 - Purchase date and invoice number;
 - Dealer name, address, and telephone number and salesperson name;
 - Precise and detailed description of your problem.

Address:
ANDERSON EQUIPMENT
5125 de la Plaisance
Chesterville (Québec)
CANADA G0P 1J0

Email Service: service@anderson-equipment.com
Fax Service: 1-819-382-2218
Website: www.anderson-equipment.com

Notwithstanding the foregoing

In no event will Anderson be liable for any incidental or consequential damages or injuries, including but not limited to loss of profits, rental of substitute equipment, or other commercial or personal loss or damages arising as a result of a fundamental breach or breach of a fundamental term.

Understanding that it is our desire to always improve on our products, our company reserves the right to modify its machines, their characteristics, and their parts at any time without advance notice or obligation.

To have equipment repaired under the warranty, the customer must advise his dealer as soon as possible of the problem and request that the repairs be made according to the terms of the applicable warranty.

The dealer will describe the terms of this warranty to the customer before the retail sale and will record the date of purchase, the serial number, and the equipment description.

The customer will be responsible for transporting the equipment to / from the authorized dealer.

Replacement or repair of equipment parts must be performed by an authorized Anderson dealer. This includes parts and labour only. All work must be preauthorized by the Anderson customer service department.

Keep your original invoice or a photocopy. Please refer to your invoice whenever you order parts, have questions about the operating procedures of your machine, or for any questions you may have concerning your warranty.

If during the year following the purchase of a new machine, your Anderson equipment fails to function properly due to defective design, materials, manufacturing, or assembly, our company will repair your equipment free of charge.

The one-year warranty period begins on the date that the new equipment is sold to the customer. If your equipment is used for commercial or rental purposes, this warranty will only be valid for a period of 1 year or a maximum of 5000 bales for trailers, individual bale wrappers, and inline wrappers.

1 Anderson limited warranty



Group Anderson Inc.

Warranty Policies, Procedures, & Provisions Summary

Purpose of Warranty:

The fundamental responsibility of warranty is to correct defects in material and workmanship of the products sold by Group Anderson Inc. (hereafter called "Anderson"). This outline is intended to assist you in awareness of Anderson's Warranty Policies and to assure that you obtain the best service possible for your Anderson machine.

- Warranty is limited to 1-year (12months). This specified period begins on the date the new equipment is sold to the customer.
- Warranty is non-transferable in the event of resale unless the resale is through an authorized Anderson dealer.

Warranty Exemptions:

- Your warranty may be voided if Anderson determines that the equipment has been subjected to bad treatment or negligence, has been used inappropriately, has not received necessary maintenance, not been appropriately protected during storage, damaged by vandalism, bad weather, natural elements, collision, or an accident.
- The warranty is void if your equipment has been modified in any way without Anderson express authorization.
- The warranty does not cover towing expenses or service calls.
- No warranty is extended to regular service items such as fluids, paint, tires.
- Certain parts, such as the Honda engine and battery are covered under warranties from their respective manufacturers. Details on these warranties can be obtained from your dealer.
- Warranty does not cover damage caused by harsh weather conditions or unstable ground conditions. Such as frozen parts on the equipment or performance issues on inadequate terrain.
- No warranty is issued for performance issues. Including downtime and capacity issues.

No Dealer Warranty:

- Except for conditions or warranties which may not be excluded by law, the selling dealer makes no warranty of its own on any item warranted by Anderson Group unless it delivers to the purchaser a separate written warranty document specifically warranting the item. The selling dealer has no authority to make any representation or promise on behalf of Anderson or to modify the terms or limitations of this warranty in any way.

Anderson's Responsibilities:

- In the event that parts must be shipped from Anderson, freight will be paid by Anderson and will be shipped by the most economical means to arrive in the shortest possible time. Air, Next Day Air, Priority and other special shipment methods requested by the Dealer will be at the Customer's expense.

ANDERSON GROUP

5125 de la Plaisance

Chesterville (Québec)

CANADA G0P 1J0

PH: (819) 382-2952

EMAIL: service@grpanderson.com

Stop the engine and remove the switch key (from the tractor and/or from the hydraulic unit) before performing maintenance, adjustments, or repairs. Release the oil pressure before moving beneath certain hydraulically lifted parts and be aware of the blade or the plastic film cutter. Replace all defective or worn out parts. We recommend you use original or approved parts in order to protect your warranty and to obtain optimal performance from your machine.

Safe Maintenance and Repair

The clothes that you wear as an operator must be safe. Avoid wide sleeves and pants, scarves, and shirt or coat sleeves that could become stuck in the moving parts of the machine. Additionally, wear adequate hearing protection to reduce the danger of hearing loss due to continued exposure to the noise of the bale wrapper. Also use an approved mask in dusty conditions. If you work in the evening or at night, make sure that you have sufficient lighting to work safely. Have a working fire extinguisher within arm's reach. Keep the protective shields and other security devices in place and never use your bale wrapper if they have been removed or damaged.

Prevention

Pay attention to the stickers and the warning labels that appear on your machine. Know how to make an emergency stop. Before starting the engine, make sure that all controls are in neutral position. It is always dangerous to stand on the machine. Keep fingers, hands, and feet away from moving parts: chains, gears, etc. Recall that all parts are potentially dangerous because certain parts can be activated suddenly. Be especially cautious around the plastic film cutter, which contains sharp parts under tension.

Dangerous Situations

The machine must be properly attached to the fixed drawbar of the tractor so that the bale wrapper is positioned as high as possible. To increase the stability of the bale wrapper, choose a flat and level ground and use the stabilizers, if you have that option.

Secure Attachment to the Tractor

Do not allow yourself to be disturbed during the installation or the operation of the machine. As an operator, you must be the only person to move about the machine within a security zone of 5 metres (16 feet) diameter. Keep all other people, especially children, away from the site, as well as domestic animals.

Danger Zone

Be familiar with operating procedures before using your ANDERSON bale wrapper. Also insist that these directions be followed by all who use your bale wrapper. Make sure that your operators know the emergency telephone numbers and the location of your first aid kit. Only allow the bale wrapper to be used by responsible people who have been fully trained in its safe operation.

Safe Operators

Your ANDERSON bale wrapper was designed to reduce to a minimum the risks to the operator. However, it must be used only for the work it was designed for. Additionally, since it includes a powerful hydraulic system, moving metal parts, and a gasoline engine (optional) and all these elements can cause serious injury to humans or animals, it is strongly recommended to read and to closely adhere to the following guidelines.

2 Safety

Gasoline is a very flammable substance which must be handled with care in an approved container when you fill the engine tank of your hydraulic unit. Put back in place and firmly tighten the tank cap and wipe away any spilled fuel. Never add gasoline when the engine is hot or operating. Have a working fire extinguisher within arm's reach near the baling site.

Hydraulic Oil

Any leak of pressurized oil can cause serious injuries. Do not use your hands to locate a leak, but rather an object such as a piece of cardboard. Stop the engine and release the pressure before disconnecting or reconnecting the lines. Firmly tighten all connections before restarting the engine or reapplying hydraulic pressure.



Any hydraulic fluid that makes contact on or underneath the skin must be removed within hours by a doctor familiar with this type of injury. Without intervention, very serious problems may result.

Travelling Safely on Public Roads

If you travel on public roads, you are responsible for respecting the identification and lighting regulations of your region. We recommend that you always attach a security chain to the hitch point between the machine and your tractor and that you lock the coupling link with a pin.

Attach the turntable's (Figure 2.1) L-shaped lock (1). Rotate the table as needed so that the latch faces the notch (2) at the front of the frame. Remove the latch pin. Slide the latch toward the notch and insert the latch shaft. Place the pin in the hole of the notch.

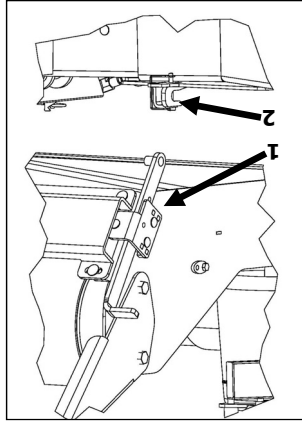

Figure 2.1 Lock of the turntable

End of Operation

If you will not use the bale wrapper again for a long period of time, do not forget to close the engine fuel valve (1), located beneath the choke on the right side of the engine (Figure 2.2).

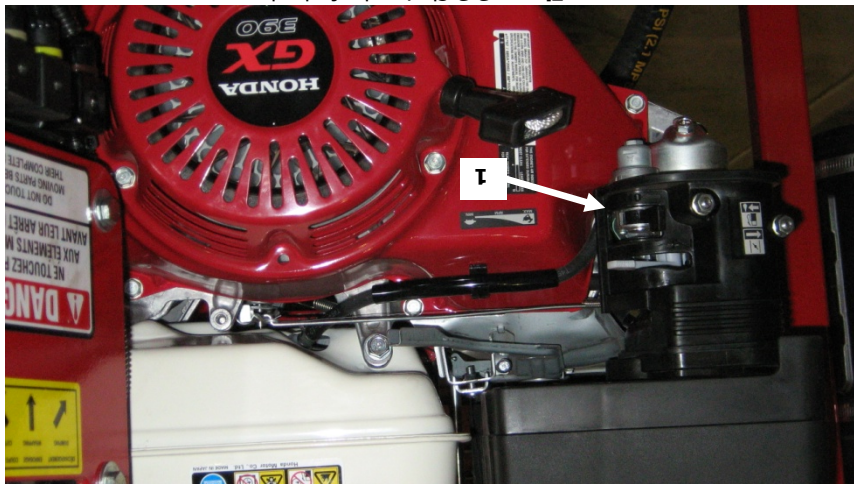

Figure 2.2 Closing the fuel valve

3 General Characteristics and Specifications

Congratulations! You are now the owner of an ANDERSON bale wrapper, a high-quality machine designed for the separate storage of round bales of up to 5 feet (1.5m) in diameter. This agricultural machine is carefully manufactured by our company to give you many years of reliable performance.

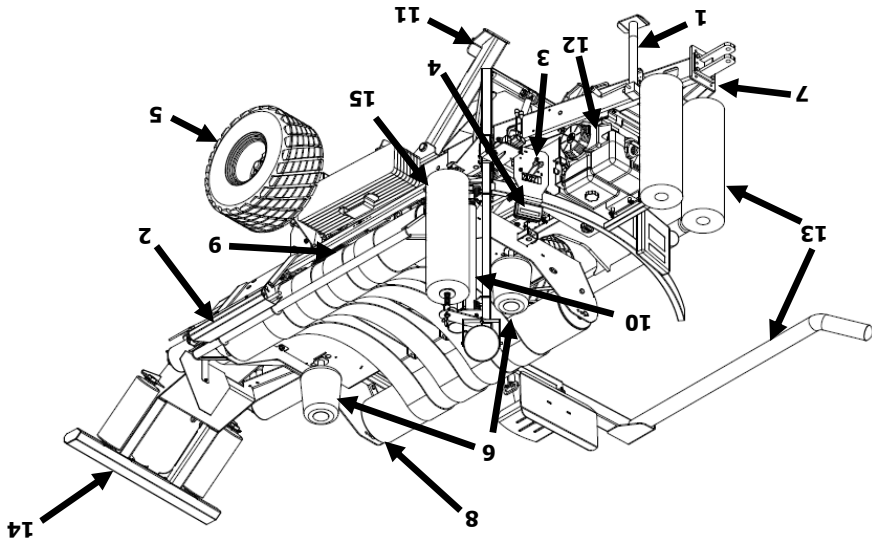

Figure 3.1 Components of the wrapper

#	Components
1	Jack with side crank
2	Mechanical film cutter
3	Manual controls
4	Bale and revolution counter
5	26 x 12 x 12 Tires (8 plies)
6	Support roller
7	Tongue
8	Turntable
9	Tilting table
10	Plastic film stretcher
Optional Components	
11	Stabilizers
12	Hydraulic unit with 13HP Honda motor and electric starter, alternator, and work lights
13	Loading arm and plastic film roll support
14	Unloading platform (D) (regular)
14	Unloading platform (D3) (3 positions)
15	Double film roll unit

* It is not possible to combine the loading arm and stabilizer options

General Specifications

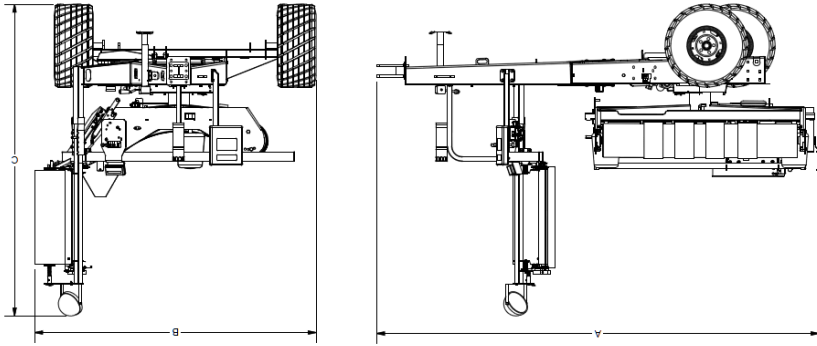

Figure 3.2 Exterior dimensions for the base model

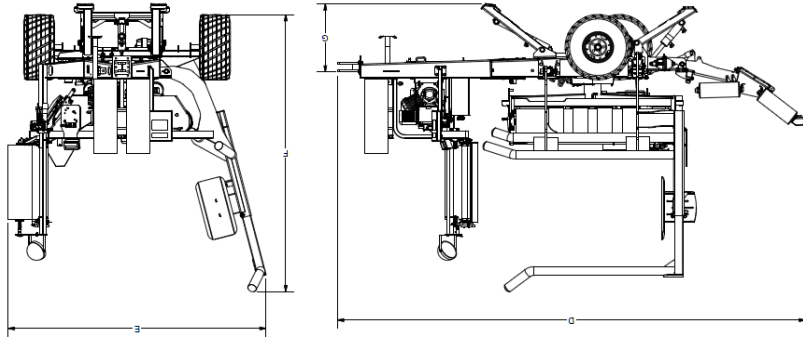

Figure 3.3 Exterior dimensions for model with optional hydraulic unit

Dimensions and Weight for base model		Dimensions and Weight for model with optional hydraulic unit	
Length (A)	140 po (3,55m)	Length (D)	187,50 po (4,77m)
Width (B)	89 po (2,26m)	Width (E)	100,75 po (2,56m)
Height (C)	99 po (2,51m)	Height (F)	118,50 po (3,01m)
Total weight*	1896 lbs (860 kg)	Weight of stabilizers	250 lbs (113 kg)
		Weight of hydraulic unit	386 lbs (175 kg)
		Weight of loading arm	Arm: 465 lbs (210 kg) Weight: 550 lbs (249 kg)
		Poids support de rouleaux plastiques	20 lbs (9 kg)
		Weight of unloading platform D	420 lbs (190 kg)
		Weight of unloading platform D3	550 lbs (250 kg)
		Weight of double film roll unit	55 lbs (25 kg)

4 Adjustment Procedures

Verifications Before Each Use

Check the hydraulic oil level in the tank of your unit if your bale wrapper is equipped with this option. Check the oil level in the Honda engine, if applicable, as well as the need for fuel. Open the fuel valve and check the engine air filter. If necessary, lubricate the machine well after each day of use. Every day, check the cleanliness of the plastic film stretcher rollers. Clean them as necessary with penetrating oil, rubbing alcohol, or paint thinner.

At start-up, your bale wrapper must be placed in the most horizontal position possible. Detach the turntable's L-shaped latch (Figure 2.1). If you have the stabilizer option, start the machine and pull the 2 levers of the control to put them in place (Figure 5.2). If the film roll is in place, check if the edge of the plastic is properly held by the clamp of the film cutter. If not, you can attach the plastic directly onto the bale ties.

Installing the Plastic Film Roll

When the film roll is empty, remove the spool by pushing it upward to compress the retaining spring of the upper support (Figure 4.1). Install the new roll in the same manner.

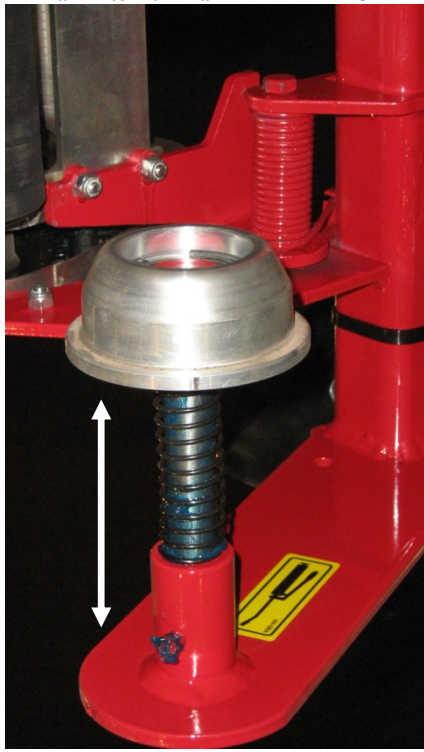

Figure 4.1 Installing the film roll

Follow the diagram (Figure 4.2) to unroll the start of the film between the rubber roller and an aluminum roller, then around the other aluminum roller. The edge of the plastic must be attached onto the ties or the net of the first bale.



Figure 4.2 Direction of film unwinding



Avoid leaving the plastic film rolls in the sun for a long period of time before using them. Prolonged sun exposure can cause the film to break or deteriorate during wrapping.

Testing the Plastic Film Stretcher

To check the effectiveness of your system, draw a 10-inch (25 cm) horizontal line on your plastic film roll with a felt-tip pen. Turn the table about one revolution and stop. Once the line has passed the aluminum rollers, measure it on the bale. If it has stretched up to a length of approximately 16.5 inches (41 cm), this means that your film stretcher is working properly. If the film does not stretch properly, check the gears of the film stretcher, and if the plastic film roll and the free roller turn freely, clean the aluminum rollers.

Adjusting the Two Support Rollers

These two conically shaped support rollers are made of rigid plastic and are placed on each end of the table between the feed rollers to hold your bale in place. In the factory, they are placed 48 inches (1.2 m) apart to hold bales of 48 inches (1.2 m) in width. Move them together or apart as necessary according to the average width of your bales by removing the pins beneath the table and changing their position. The support rollers can hold bales up to 60 inches (1.5 m) in width (Figure 4.3).

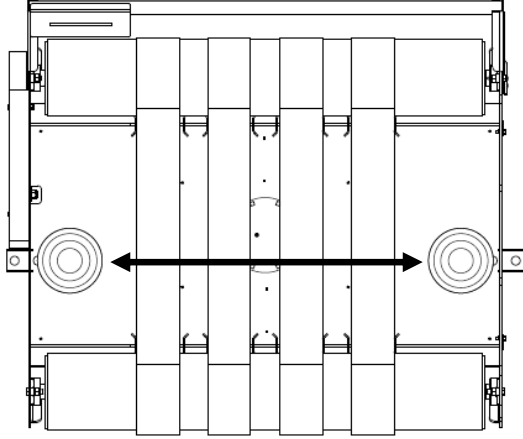

Figure 4.3 Adjusting the support rollers

5 Operating Procedures

5.1 Moving the Bale Wrapper

Short and Medium Distances

Your machine can be moved short and medium distances behind a tractor. Fasten the turntable latch (Figure 2.1). Attach the machine and attach a security chain to the ring provided for this purpose on the draw bar. On public roads, follow the traffic regulations of your region for agricultural machines, including those concerning the use of agricultural machines by minors.

Safety Measures



Regardless of method, during transportation, do not stand on and do not let anyone else stand on the machine.

WARNING !



Close the fuel valve if it is necessary, because the gasoline could leak into the engine base.

5.2 Using the IG-C3 Bale Counter

Characteristics

The IG-C3 bale counter is powered by a rechargeable battery. Use the provided AC/DC charger as needed. The module consists of a 2-line screen with 4 buttons beneath it. Start up the counter by touching the **ON/OFF** button on the left. This opens the first **Anderson** window. Five seconds later, the screen will look as follows:

- In the upper left corner of this window, **rev: 00** will count each wrapping as you operate the bale wrapper.
- On the second line of the window, **Bales (D): 000** shows the total bales wrapped in the day.
- In the upper right corner, **MAX: 18** shows the maximum number of revolutions programmed for each bale. When your number of revolutions approaches this number, the screen will begin to blink. You will hear three warning beeps, but the machine will not stop automatically. Bales/total will increase by 1, and after 15 seconds, the number of revolutions will return to 0.

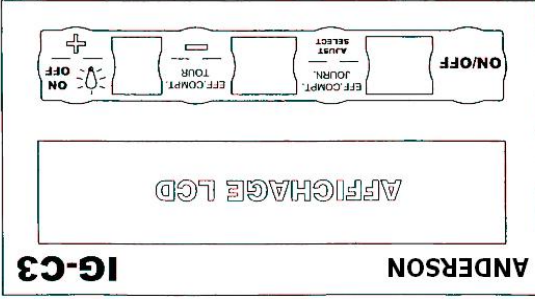

Figure 5.1 Bale counter screen

WARNING !

If you do not use the optional hydraulic unit, adjust your tractor at a flow rate of 8 GPM at 2000 PSI.

Make sure your bale counter has been properly programmed.

Start-Up**5.3 Start and End Wrapping**

- You have finished programming the bale counter and the **ADJUST.SELECT** menu will bring you back to the operation menu.
- Program 4: Choose your language with the **- / +** buttons: French or English, which allows you to: **modify # bales Year: 0000**.
 - Program 3: Pushing the **ADJUST.SELECT** button a third time will take you to program 3, press the **- / +** buttons simultaneously, the number will be reset to zero.
 - Program 2: Pushing the **ADJUST.SELECT** button again will take you to program 2, which allows you to **modify # bales Day: 000** (in the same manner as for program 1). If you press the **- / +** buttons simultaneously, the number will be reset to zero.
 - Program 1: The 1st program allows you to: **Enter the number of revolutions, MAX: 00** per bale by pushing the **- / +** buttons. The minimum number is 2 and the maximum is 80. Holding down one of the **- / +** buttons for 3 seconds will cause the number to change surfaces of the bale. Certain users will want more layers or fewer layers.
- To reach this menu, hold down the **ADJUST.SELECT** button for 3 seconds.

Advanced Menu of the IG-C3 Bale Counter

- To shut down the module and close the operation MENU, press the **ON/OFF** button on the left. The date will be saved. When not being used, the bale counter will go into energy saver mode after 5 minutes.
- The **ON / OFF** button on the right allows you to turn on or off the illumination of the screen during operation. The internal battery consumes 10 times less energy when the screen is turned off. The illumination of the screen automatically turns off after 20 seconds if the counter is not being used.
- Similarly, the **ER.COUNT.REV.** button allows you to reset the revolution counter to zero during a test or during a missed cycle. You must confirm the operation.
- If you press the **ER.COUNT.DAY.** button, the screen will ask you to confirm **NO** or **YES** **+** whether you really want to erase the daily counter.

Operation Menu of the IG-C3 Bale Counter

If you have the hydraulic unit, shut off the fuel valve to prevent the gasoline from seeping into the engine oil. Once your batch of bales has been stored, take the time to check the air tightness of the plastic film on your bales. As necessary, seal the air leaks with tape so that fermentation will begin rapidly. Use the tape recommended by your plastic film supplier.

End Bale Wrapping

Warning !



Tilt the table when it is badly aligned may cause damage to your machine.

Take the time to properly align your table well so that the bale falls backward from the wrapper and the plastic film cutter system forward, then pull its lever (4) to tilt the table. During this operation, the plastic film cutter will be engaged and will cut the plastic film and hold onto one of the cut ends. Next, lower the table again and place a new bale on the feed rollers. The first bale can be retrieved from the ground.

Unloading and Second Bale

Take a round bale and place it in the center of the feed rollers, preferably on the side opposite the plastic film stretcher. The bale will turn counterclockwise. Attach the edge of the plastic film to the ties or net of the bale. Pull the wrapping lever (3). Wrapping will begin. When you hear 3 beeps. Stop wrapping when the table is properly aligned (the axis of the bale must be parallel to the axis of the axle).

First Bale

Note: With the Hydraulic Unit and Stabilizers options, only one tractor is needed to continuously wrap bales.

#	FUNCTION
1	Rear stabilizer
2	Front stabilizer
3	Wrapping lever
4	Tilt the table

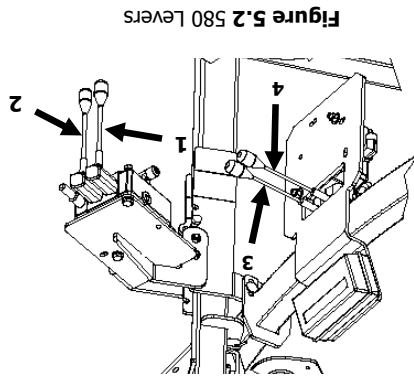
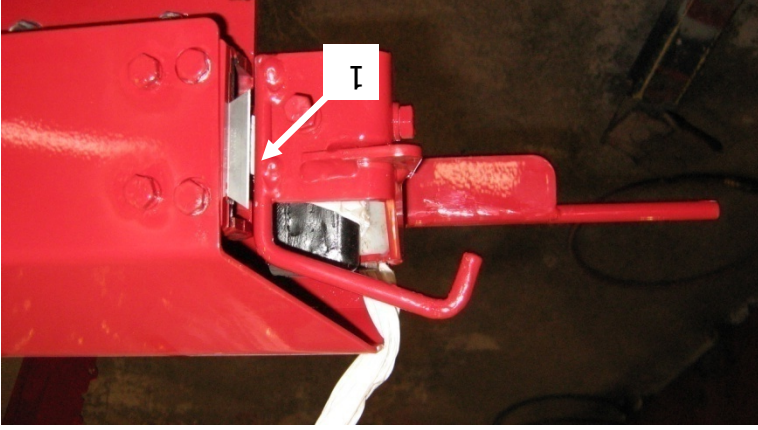

Figure 5.2 580 Levers

Once the table's latch has been removed, use the levers to lower the rear (1) and front (2) stabilizers (Figure 5.2) if applicable. Depending on the hardness of the ground, it is possible that after a dozen bales you will have to manually readjust the stabilizers to solidify your machine or keep it properly horizontal.

Levers

Figure 5.4 Plastic film cutter blade



First, check the condition of the steel blade (1) and replace it as needed (Figure 5.4). Increase the force of the stopper spring as needed. Move the bolt (2) holding the spring in a hole, thereby making it possible to further compress the spring (Figure 5.5) for a better hold on the plastic. Reposition the blade (3) to change when the plastic film cutter closes during bale unloading. Ideally the plastic film cutter is actuated just before the table is fully lifted.

5.5 Adjusting the Mechanical Plastic Film Cutter

Figure 5.3 Rotation counter sensor

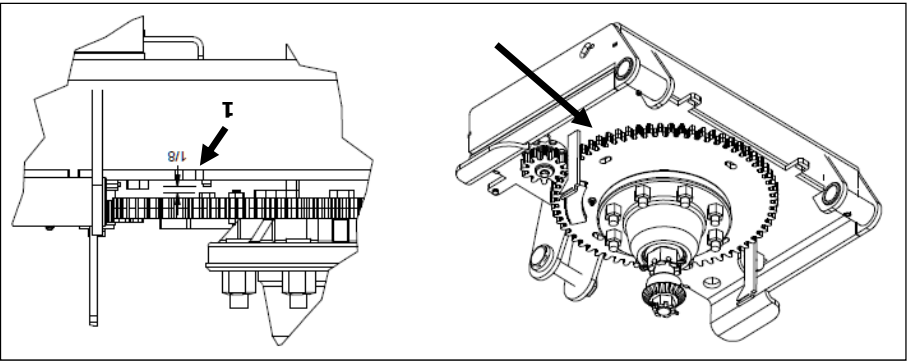

Place the 2 parts of the sensor at position 1 so that they face each other, turning the table by pulling the control valve lever, and adjust the distance between them to 1/8 inch (2.5 mm)(Figure 5.3)

5.4 Bale Wrapping: Adjusting the Sensors Adjusting the Rotation Counter Sensor

Figure 5.6 Adjusting the plastic film cutter blade (at rest)

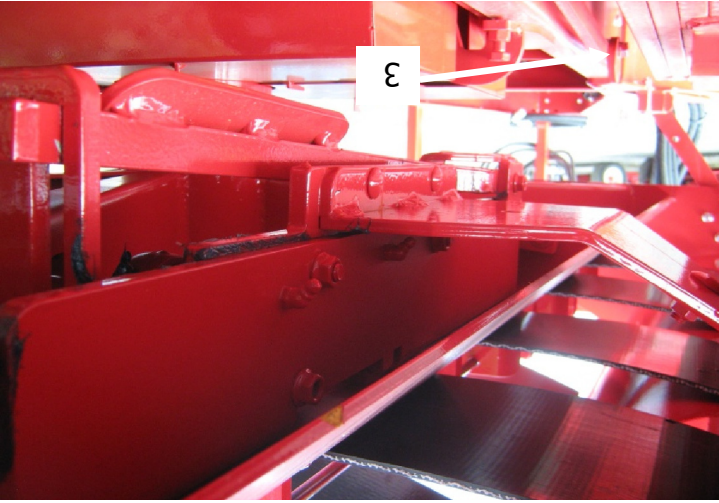
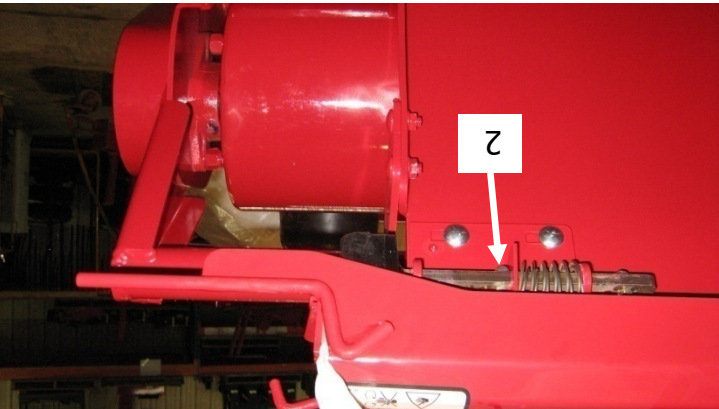

Figure 5.5 Stopper spring and adjustment bolt



6 Maintenance Procedures

Maintenance



Warning !

Before performing any maintenance operations on your machine, ensure that you are following the security precautions laid out in the safe maintenance and repair section : stop the engine (of the tractor or the unit), turn off the receiver, release hydraulic pressure, etc.

Grease Gun Lubrication

Your ANDERSON bale wrapper must be lubricated with a grease gun in the places indicated by the sticker (Figure 6.1).



Figure 6.1 Grease gun lubrication



Note: The use of synthetic grease is highly recommended



Greasing Frequency



Frequency	Greasing (number of grease cups)
Every 200 bales	Pivot of plastic film roll support (1) Central axle of turntable (1 on the top) Pivots of tilting table (2) Axles of the tilting cylinder (2) Axles of the unloading platform cylinder (2)* Pivot of the unloading arm (2)* Axles of the unloading arm cylinder (2)* Pivot of the unloading platform (4)*
Every 500 bales	Front and rear stabilizers (4)*
Every 1000 bales	Bearings of the two feed rollers of the belts (1 on each end, total of 4)

* Optional equipment

	Pivot of plastic film roll support (1)
--	--

 <p>A close-up photograph of a red tractor's rear linkage system. Two white arrows point to the axles of the hydraulic cylinders that control the tilting of the PTO shaft. A yellow warning label is visible on the right side of the frame.</p>	<p>Axles of the tilting cylinder (2)</p>
 <p>A close-up photograph of the pivot point where the red PTO shaft meets the tractor's main frame. A white arrow points to the pivot pin. The frame is heavily bolted.</p>	<p>Pivots of tilting table (2)*</p>
 <p>A close-up photograph of the central axle of the turntable at the top of the PTO shaft. A white arrow points to the axle. The turntable is supported by curved metal plates.</p>	<p>Central axle of turntable (1 on the top)</p>

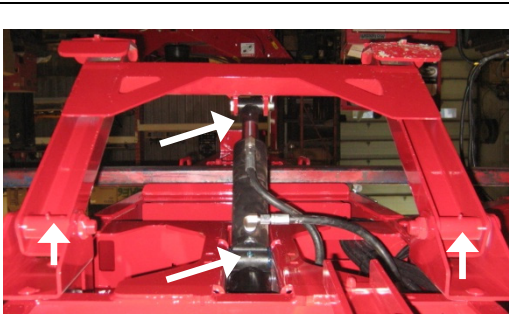
	<p>Axes of the unloading arm (2)*</p>
	<p>Pivot of the unloading arm (2)*</p>
	<p>Axes of the unloading platform cylinder (2)*</p>

	<p>Bearings of the two feed rollers (1 of the belts (1 on each end, total of 4)</p>
	<p>Front and rear stabilizers (2 grease cups (each) and cylinder axles (2 each)*)</p>
	<p>Pivot of the unloading platform (4)*)</p>

Other Lubrication Points

The power transmission chains and other moving parts of the machine must be oiled or greased regularly or every 50 hours. This also applies to the 2 toothed wheels of the plastic film stretcher.

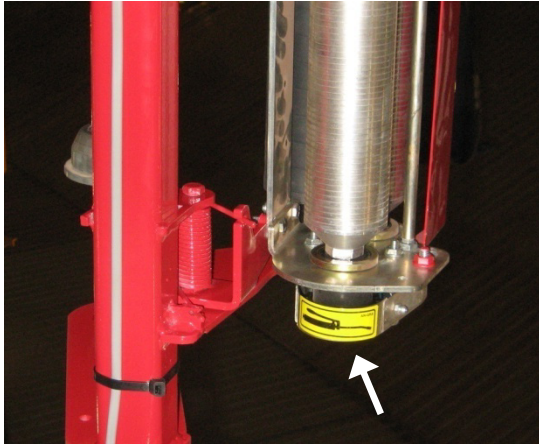

Figure 6.2 Lubricating the plastic film stretcher



Figure 6.3 Lubricating the chain (through the hole in the guard)

The film cutter must be lubricated daily (approximately 100 balls) where indicated in the following figures:

Use a anti-friction lubricant to lubricate the film cutter system.

IMPORTANT!



Do not use grease because it causes the accumulation of dust that affect the lubricating.

Also remove the hay that can get stuck in the axles and gears of the machine to not place needless strain on the hydraulic motor.

For the maintenance of the hydraulic unit, we recommend that you follow the Honda instruction manual for the maintenance of your engine. Check the oil level of the HONDA engine on each day of operation. The engine air filter must be checked each time you begin wrapping and you perform this maintenance every 5000 wrapped bales. It is a good idea to free the area around the gasoline engine of all flammable material.

Pay particular attention to the cleanliness of the plastic film cutter system. An accumulation of debris (hay, dust, string, etc.) can reduce its functionality. Regularly check the cutting condition of the blade.

Always keep the rollers and the gears of the plastic film stretcher free of all residues to prevent these parts from jamming, breaking, or tearing the plastic film. As necessary, wash the aluminum rollers with rubbing alcohol, penetrating oil, or paint thinner.

Cleaning and Other Maintenance

Figure 6.5 Lubricating the plastic film cutter 2



Figure 6.4 Lubricating the plastic film cutter 1



Storage

To unhitch the machine, follow these steps:

During unhitching operations, the operator is the only person authorized to be near the machine.

Warning !



Before lowering the tractor to remove the hydraulic connections, and the electric cables, the operator must ensure that the machine is fully on the ground and stable. S/he must also engage the hand brake, turn off the tractor, and remove the key from the ignition switch.

- Secure the machine in a stable location.
- Use chocks to prevent the machine from moving while being unhitched from the tractor.
- Disconnect the hydraulic connections from the tractor.
- Disconnect the power cables.
- Remove the fixing pin and the security chain to rotate the jack.
- Replace the fixing pin and the security chain.
- Lift the pole with the jack.
- Remove the fixing pin and the security chain.

Warning !



Ensure that you have released the hydraulic pressure from the tractor's system to make disconnection and future reconnection easier.

- Remove the bale counter and store in a dry place.

It is preferable to keep the machine in a dry, covered place so that it will be in good condition when it is used again.

Problems	Possible Causes	Solutions
1. The IG-C3 counter does not turn on.	Lack of power.	Install the provided AC/DC charger or the charge wire on the module.
2. The IG-C3 turns on but does not count revolutions.	Defective sensor or problem with wiring or connections.	Check the wiring and connections, replace the sensor if necessary.
3. The engine of the hydraulic unit does not start.	The fuel valve is closed.	Open the fuel valve and start again.
	The gas tank is empty.	Put fuel in the tank and start again.
	The low engine oil sensor is activated.	Add oil to the engine and start again.
	The spark plug is clogged or defective	Clean the spark plug or change it.
	The engine is flooded because the fuel valve was not closed the previous day or during transportation.	Remove the spark plug, dry it out, dry out the cylinder by activating the starter crank. Put back the spark plug and start again.
	The fuse in the HONDA switch key box is burned out	Replace the fuse (Figure 7.1)
	The level of hydraulic oil or the flow rate of the hydraulic unit or the tractor is too low	Check for oil leaks and breaks. Retighten or repair as necessary. Add hydraulic oil to the tank. Check the tractor's flow rate (8 GPM).
	The HONDA motor turns too slowly.	The motor must be adjusted to 3600 revolutions/min.
4. The turntable does not turn or turns slowly.	The level of hydraulic oil or the flow rate of the hydraulic unit or the tractor is too low	Check for oil leaks and breaks. Retighten or repair as necessary. Add hydraulic oil to the tank. Check if all the rollers are turning freely. The film is too soft because it has been in the sun for too long before being used. Install a cooler roll. Check if the plastic film roll is properly installed.
		The plastic film is not tight enough on the bale.
	The plastic film breaks, develops holes, or tears during wrapping.	Check if the plastic film roll is properly installed.
		Check if the parts of the plastic film stretcher are in good condition and turn freely. Repair as needed.
		Check if hay or something else is inhibiting or blocking the plastic film stretcher. Remove the object and clean the film stretcher. Check if all the rollers are turning freely.
		Check if the roll installed was damaged to begin with and replace it if necessary.
5. The plastic film wrapping is unsatisfactory.	The plastic film breaks, develops holes, or tears during wrapping.	Check if the plastic film roll is properly installed.
		The rubber stopper moves back too far on its adjustment bolt. Adjust the bolt. The stopper spring needs to be more tense (Figure 5.5).
		The plastic film cutter clamp does not hold onto the end of the plastic film.
6. The plastic film cutter does not work well.	The plastic film cutter clamp does not hold onto the end of the plastic film.	Adjust the bolt. The stopper spring needs to be more tense (Figure 5.5).

Troubleshooting Table

7 Troubleshooting: Problems and Solutions

Before calling a technician, examine your machine and consult the table below to find a solution. If you are still not able to solve the problem yourself, ask for help from the customer service department of your agricultural dealer.

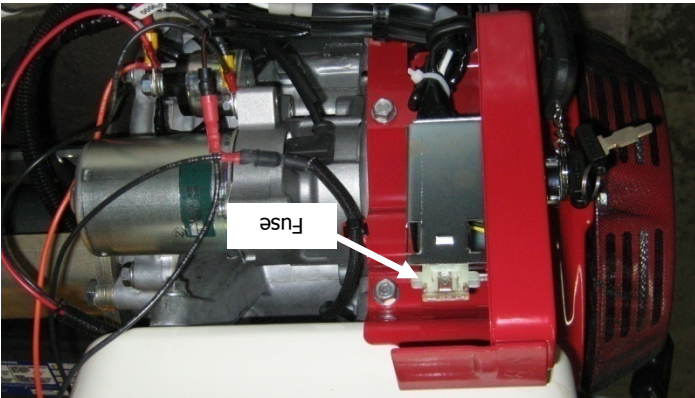

Figure 7.1 Starter fuse

8 Optional Equipment

Hydraulic Unit

The 580 bale wrapper can function with your tractor's hydraulic system or with an optional independent hydraulic unit which includes:

- A 13 horsepower Honda gasoline engine;
- A pump adapter and a hydraulic pump;
- A hydraulic oil tank with oil filter and strainer.

We recommend that you follow the Honda instruction manual for the proper maintenance of your engine.

The engine air filter must be checked at the start of each wrapping session and cleaned as needed.

We recommend that you change the hydraulic oil, the filter, and the strainer every 5000 wrapped bales.

IMPORTANT!



Electric starter with 18 amp. alternator and work light

These 2 options complement the Honda engine of the hydraulic unit. The work light (1) is installed on top of the plastic film stretcher (Figure 8.1).

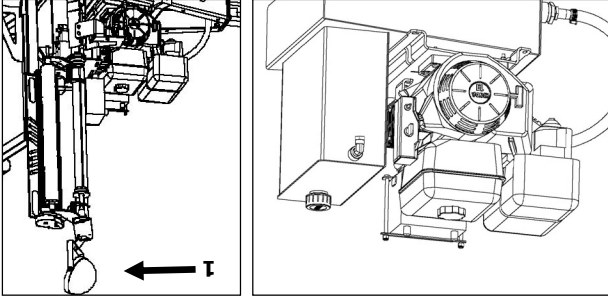

Figure 8.1 Hydraulic unit and work light

Stabilizers

Activated by hydraulic cylinders and controlled by manual controls at the front of the machine, these two pieces of equipment improve the stability of the bale wrapper. They are equipped with security valves (lock valves) to prevent inadvertent movement of stabilizers or the feet from collapsing, whether the machine is turned on or not. The stabilizer option and the hydraulic unit option make it possible to completely detach the bale wrapper and to function independently, one tractor is required to handle bales.

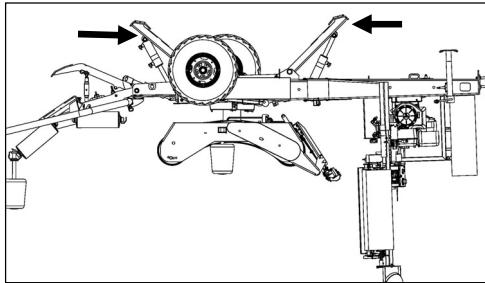

Figure 8.2 Stabilizers

Modifying Gears to Reduce Stretch Ratio

It is possible to modify the standard stretch ratio (65%) by changing the gears of the plastic film stretcher and thereby obtain a ratio of approximately 55%. Contact your dealer to obtain this accessory.

Bale Loading Arm and Plastic Film Roll Support

As an option, a loading arm can be installed on the bale wrapper **only at Anderson manufacture**. This arm makes it possible to load bales directly onto the bale wrapper without using a frontal loader.

1. The loading arm option is always sent with extension cables to control the wrapper from the tractor seat and a rack to carry two extra rolls of plastic.
2. For loading the bale, the turntable must be parallel to the loading arm.
3. The loading arm is equipped with a safety device to prevent collisions with the turntable and error operations. The loading arm must be dropped halfway between the turntable and the ground so that the table can rotate and wrap.
4. Adjustment of the loading arm :
Fork outer arm adjusts to different bale diameter. An adjustable backstop allows you to charge balls of 4 or 5 feet (1.2 m or 1.5m) wide and filed on the center of the turntable.
5. Transport

This unloading ramp makes it possible to gently discharge wrapped bales behind the bale wrapper. This system is composed of a rigid platform, a hydraulic cylinder, and a maintenance-free nitrogen cylinder.

Figure 8.4 Bale unloading platform D

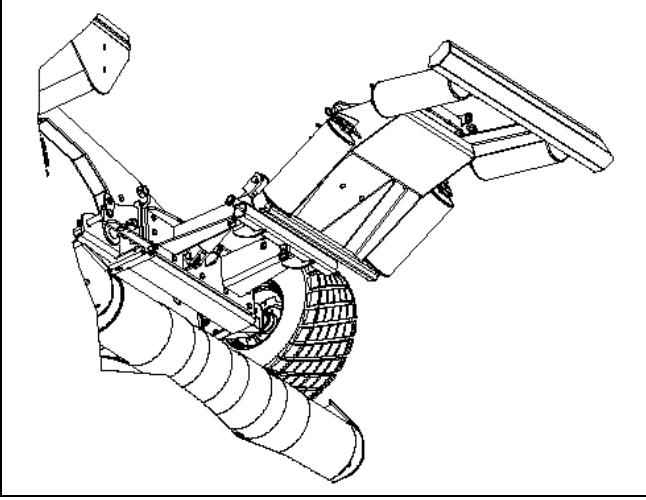

Bale Unloading Platform (D)

Figure 8.3 Bale loading arm

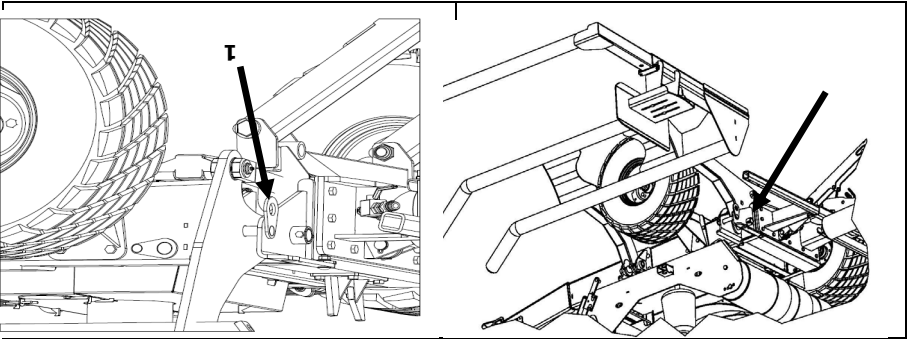

WARNING !
To transport the wrapper equipped with a loading arm, install the safety pin (1) that keeps the loading arm upright.



Here are the steps to install the unloading platform D3 from the unloading platform D :

Installation of the three position unloading platform (D3)

With the D3 option, it is possible to gently discharge bales on the cylindrical side (without rotation). The operator need only raise the foot, remove the support roller (1), and ensure that the 2 platform barriers are installed to limit movement.

WARNING !



For transport, it is necessary to manually retract the retaining bar (2) (Figure 8.5).

This optional equipment makes it possible to bring the bales to a vertical position and set them down on the flat side. Additionally, this unloading platform makes it possible to turn bales on one side or the other according to the preference of the user. To make this change, the operator need only place the barrier (6) on top of the platform, the foot (4), the support roller (1), and the retaining bar (5) on the other side of the unloading platform. The same attachment points are situated on each side of the platform to facilitate the change.

Figure 8.5 Bale unloading platform D3

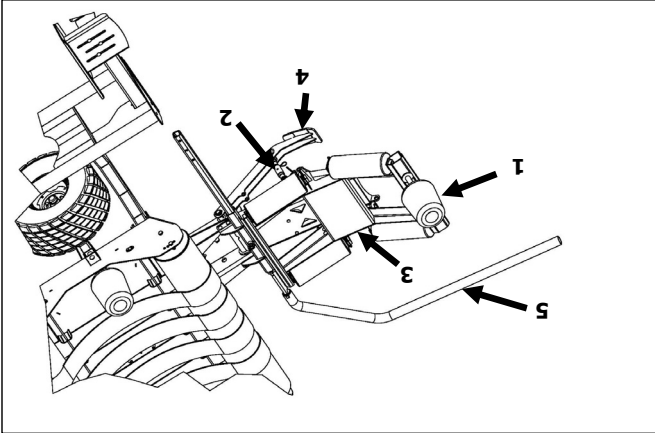

Unloading Platform (D3)

Install the support of the arm.



Attaching the retaining arm on the support

Slide the foot on the shaft and lock in place with the linchpin. (1).

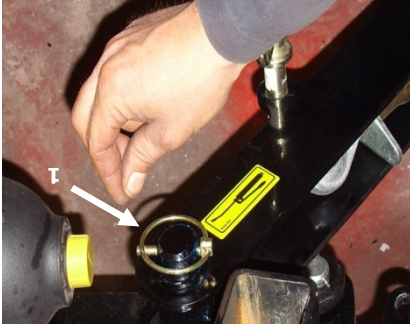

Sand the shaft.



Installation of the foot

		<p>You can now attach the "L" shaped bar to the straight bar. (4 bolts)</p>
	<p>Insert the fixed part of the arm into the support.</p>	

Installation of the retaining arm

	<p>Place the support on the dumping unit and bolt into place. Holes on the dumper are predrilled from the factory.</p>
---	--

Installation of the cone shaped roller

	<p>Remove the deflector at the end of the dumper to reveal the placement holes for the cone shaped roller.</p>
	<p>Place the cone shaped roller on the same side as the foot as you will be bumping the bale to the opposite side.</p>

This procedure is for if you are dropping the bale to the left side. The same procedure is used when dumping to the right side but the foot and cone roller will be placed on the other side of the machine. Also the "L" shaped retaining arm must be inserted opposite to the procedure.

Charging the accumulator

When the unloading platform does not go back to its position, you must correct the pressure in the accumulator to a pressure ranging from 1000 to 1200 lbs. A too low pressure will not lift the unloading platform to its position and a too high pressure will not allow the bale to dump from the unloading platform.

1. Remove the handle (1)
2. Turn the lock washer (2) to enable the handle to turn and open the ball valve (4).
3. Replace the handle (1).
4. Connect a hydraulic pump at the male quick connect (3).
5. Open the ball valve (4). The unloading platform will go down.
6. Put hydraulic oil to achieve a pressure of 1000 lbs. Press on the unloading platform for to verify if he goes back to its position and adjust the pressure as required.

Figure 8.7 Double roll unit



The double roll option allows to install two plastic film rolls on the plastic film roll stretcher, thereby making it possible to apply a double layer of plastic with each rotation of the table. With this option, wrapping time will be decrease by almost half, because two layers of plastic are applied simultaneously.

Double Roll Plastic Unit

If using a tractor for this procedure we recommend that you put a relief valve between the wrapper and the tractor. This way you can fully open the oil from the tractor and regulate it with the relief valve.

Figure 8.6 Accumulator of the unloading arm

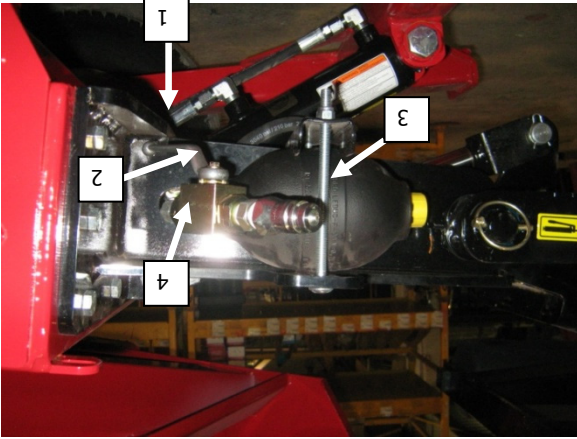

7. Close the ball valve (4).
8. Remove the handle (1).
9. Turn the lock washer (2) that its lock the handle.
10. Replace the handle (1).

9 Start-Up Procedures

When you receive your new ANDERSON equipment:

Stationary mode:

1. Attach the bale wrapper to the tractor or stabilize the machine with the stabilizers and start the engine HONDA.
2. Remove the table lock on the bale wrapper (Figure 2.1).
3. Install a plastic film roll (Figure 4.1).
4. Enable the tractor hydraulic system or start the Honda engine.
5. Place a bale on the table, centered between the support rollers.
6. Attach the edge of the plastic film to the ties of the bale.
7. Pull the lever to begin wrapping (Figure 5.2).
8. Adjust the revolution of the engine to the wrapping speed desired.

Field mode:

1. Remove the table barrier on the bale wrapper (Figure 2.1).
2. Install a plastic film roll (Figure 4.1).
3. Enable the tractor hydraulic system or start the HONDA engine.
4. Place a bale on the table with the loading arm.
5. Only for the first bale, attach the end of the plastic wrap on the rope or bale net.
6. Pull the lever to begin wrapping (Figure 5.2).
7. Adjust the revolution of the engine to the wrapping speed desired.

VERSION
PRELIMINAIRE

ALWAYS KEEP THIS MANUAL WITH THE WRAPPER

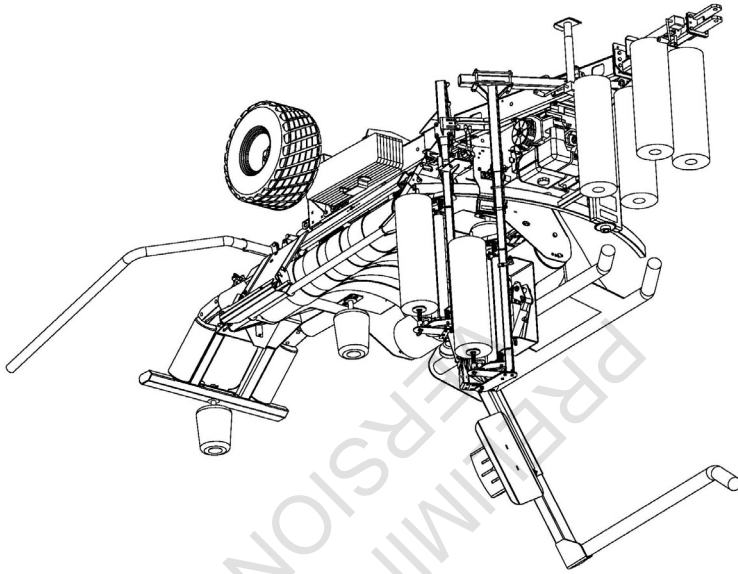

ROUND BALE WRAPPER
RB580

Parts manual



ANDERSON



PRELIMINARY
VERSION

Visit our website → www.granderson.com

Email : service@granderson.com
 Fax : (819) 382-2643

CANADA GOP 1J0
 Chesterville (Québec)
 5125 de la Plaisance

ANDERSON GROUP

For any parts order, please use the parts manual to find the item(s) you need and contact your dealer to order it or contact us directly at :

1	Main Frame	P. 2
2	Plastic Roller Frame, Coupling Hand and Tongue	P. 4
3	Axle	P. 5
4	Stretcher Support Arm	P. 6
5	Stretcher Support	P. 8
6	Stretcher	P. 10
7	Dumping Table	P. 12
8	Shield	P. 16
9	Rotary Table and Cut and Hold	P. 18
10	Power Unit (option)	P. 26
11	Loading Arm	P. 27
12	Double plastic roll (option)	P. 32
13	Drop Off (option)	P. 34
14	Stabilizer (option)	P. 38
15	Hydraulic Diagram	P. 40

Content

ANDERSON



1 - MAIN FRAME

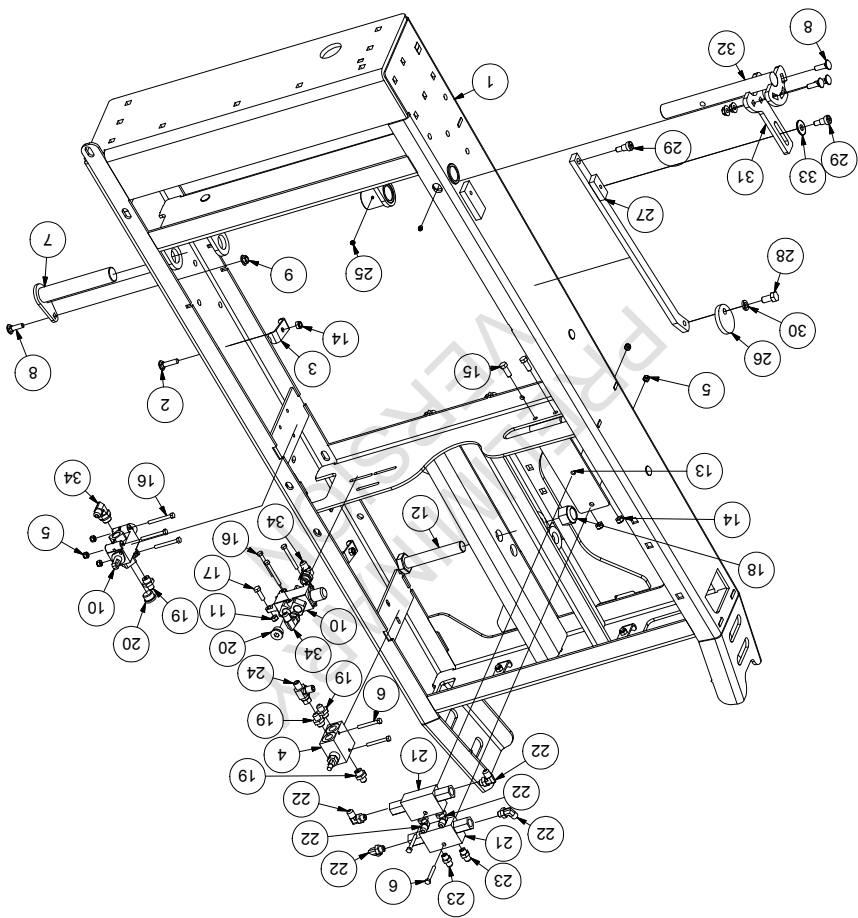

ITEM	QTY	PART	DESCRIPTION	NOTE
1	1	222000-1	FRAME	
2	7	500444	CARRIAGE BOLT	
3	5	223001	HOSE ATTACHMENT	
4	1	466000	CUSHION VALVE	
5	10	501030	NYLON NUT	
6	4	500014	BOLT	
7	1	223003	PIVOT AXLE	
8	4	500443	CARRIAGE BOLT	
9	4	501022	FLANGE UT N	
10	2	465063	VALVE	
11	1	501031	NYLON NUT	
12	1	500334	BOLT	
13	1	222001	VALVE SUPPORT	
14	9	501032	NYLON NUT	
15	2	500084	BOLT	
16	6	500016	BOLT	
17	1	500044	BOLT	
18	1	501037	NYLON NUT	
19	4	451172	HYDRAULIC FITTING	
20	2	451355	HYDRAULIC FITTING	
21	2	466989	VALVE	
22	6	451260	HYDRAULIC FITTING	
23	2	451171	HYDRAULIC FITTING	
24	1	450972	HYDRAULIC FITTING	
25	2	322299	GREASE FITTING	
26	1	222042	TRIGGER ARM TIP	
27	1	222041	TRIGGER ARM	
28	1	500173	BOLT	
29	2	500570	SHOULDER SCREW	
30	1	502048	LOCK WASHER	
31	1	222044	TRIGGER ARM ADJUSTMENT	
32	1	222043	DUMPING TABLE AXIS	
33	1	502006	FLAT WASHER	
34	3	451261	HYDRAULIC FITTING	

2 - PLASTIC ROLLER SUPPORT, COUPLING HAND AND TONGUE

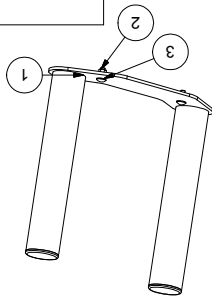

ITEM	QTY	PART	DESCRIPTION	NOTE
1	2	224082-1	PLASTIC ROLLER SUPPORT	
2	2	501022	FLANGE NUT	
3	2	500442	CARRIAGE BOLT	

PARTS LIST

COUPLING HAND

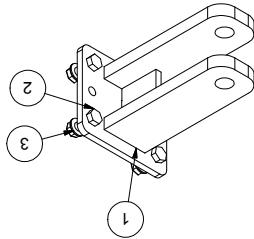

ITEM	QTY	PART	DESCRIPTION	NOTE
1	1	223076	COUPLING HAND	
2	4	500177	BOLT	
3	4	501024	FLANGE NUT	

PARTS LIST

TONGUE

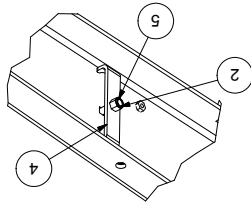

ITEM	QTY	PART	DESCRIPTION	NOTE
1	1	222002	TONGUE	
2	2	501032	NYLON NUT	
3	1	-322460	JACK	322457
4	2	223001	HOSE ATTACHMENT	
5	2	500444	CARRIAGE BOLT	

PARTS LIST

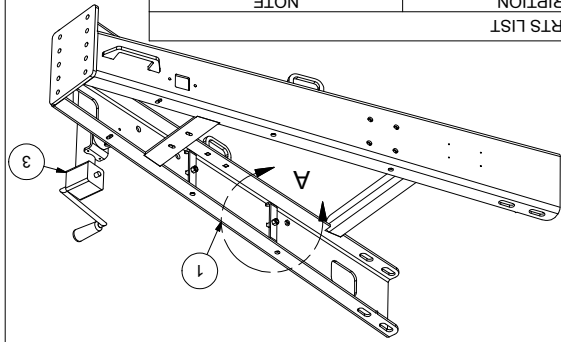

DETAIL A

PARTS LIST

ITEM	QTY	PART	DESCRIPTION
1.1	2	481400	HUB
2	13	501024	HEX FLANGE NUT GR2 1/2-13 Z
3	9	500175	HEX BOLT GR5 1/2-13 X 1 1/4
4	4	500501	CARRIAGE BOLT GR5 1/2-13 X 1 1/4 Z
5	1	223080-1	COMPLETE RIGHT AXLE
6	1	223081-1	COMPLETE LEFT AXLE
7	2	481604	TIRE AND RIM
8	2	320020	COTTER PIN
9	2	501076	HEX CASTLE NUT 1-12

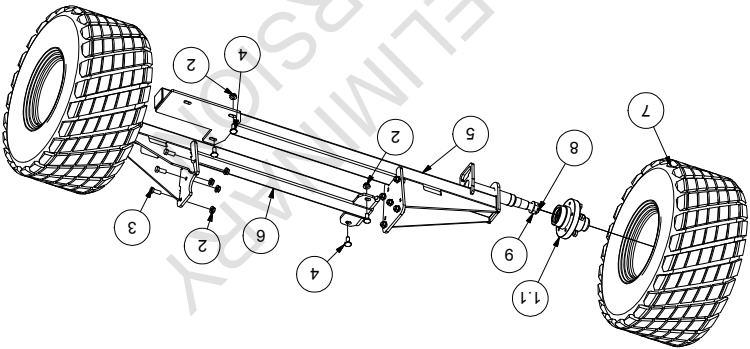

PARTS LIST

ITEM	QTY	PART	DESCRIPTION
1	1	481400	HUB
2	1	303035	BEARING LM44649
3	1	303036	BEARING LM44610
4	1	303037	ROLLING BEARING CAGE LM48510
5	1	303034	BEARING LM48548
6	1	303077	SEAL
7	1	481000	DUST CAP
8	5	507010	WHEEL BOLT 1/2-20 X 1 1/2

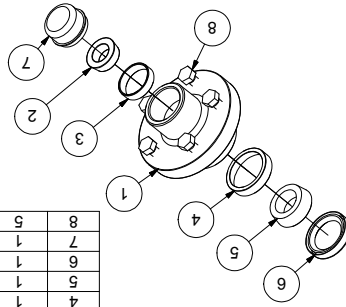

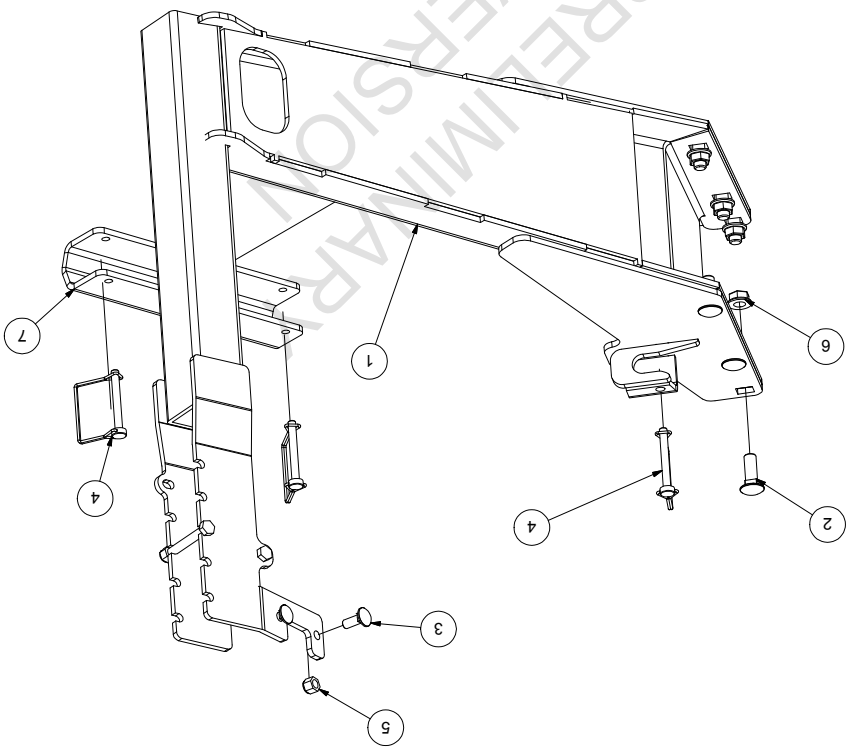

PARTS LIST

ITEM	QTY	PART	DESCRIPTION	NOTE
1	1	223067	ARM	
2	6	500502	CARRIAGE BOLT GR5 1/2-13 X 1 1/2 Z	
3	2	500442	CARRIAGE BOLT GR5 3/8-16 X 1 Z	
4	3	320021	LOCK	
5	4	501032	NYLON NUT	
6	6	501024	HEX FLANGE NUT GR2 1/2-13 Z	
7	1	224262	DUMPING TABLE SAFETY PLATE	

PRELIMINARY
VERSION

5 - STRETCHER SUPPORT

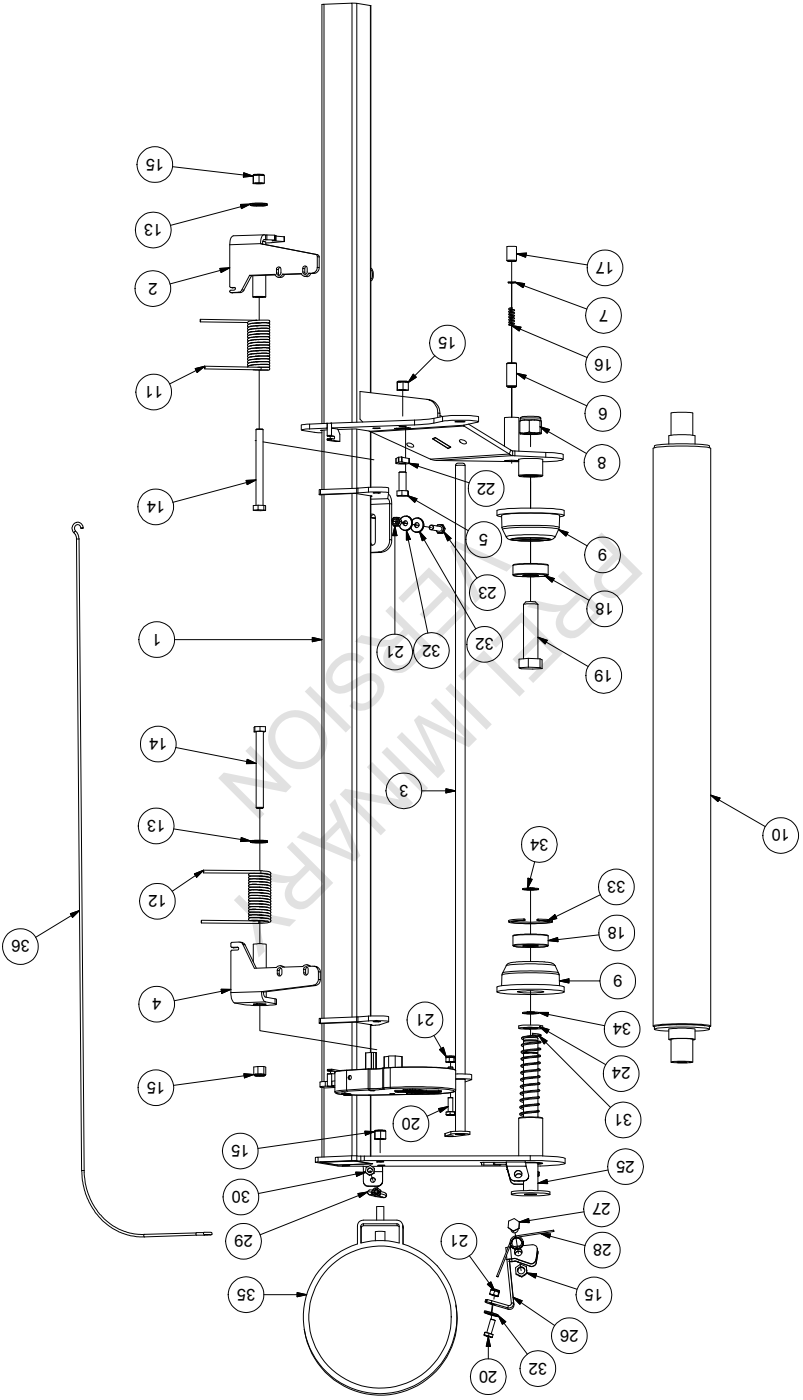

PARTS LIST			
ITEM	QTY	PART	DESCRIPTION
1	1	224076-2	STRETCHER POST
2	1	224078	SPRING HOLDER
3	1	224079	ROD
4	1	224080	SPRING HOLDER
5	1	500084	BOLT
6	1	224081	TEFLON BRAKE
7	1	502001	FLAT WASHER
8	1	501036	NYLON NUT
9	2	224082	LOWER STRETCHER ROLLER
10	1	279005	RUBBER ROLLER
11	1	304007	SPRING
12	1	304008	SPRING
13	2	502004	FLAT WASHER
14	2	500104	BOLT
15	5	501032	NYLON NUT
16	1	304023	SPRING
17	1	507036	HEX SOCKET SET SCREW CUP 1/2-13 X 3/4
18	2	303012	BEARING 6204RS-750
19	1	500289	HEX BOLT GR5 3/4-10 X 3
20	8	500004	BOLT
21	12	501030	NYLON NUT
22	1	223195	LOCK
23	5	500006	HEX BOLT GR5 1/4-20 X 1
24	1	224260	WASHER
25	1	224077-1	PIN
26	1	224261	PLASTIC SUPPORT LOCK
27	1	500098	BOLT
28	1	304063	SPRING
29	1	507066	EYE BOLT
30	1	501000	HEX NUT 1/4-20 Z
31	1	304009	SPRING
32	3	502002	FLAT WASHER
33	1	320056	RETAINNING RING INT. 2
34	2	320088	RETAINNING RING EXT. 3/4 B
35	1	319880	WORKING LIGHT
36	1	325181	CABLE

6-STRETCHER

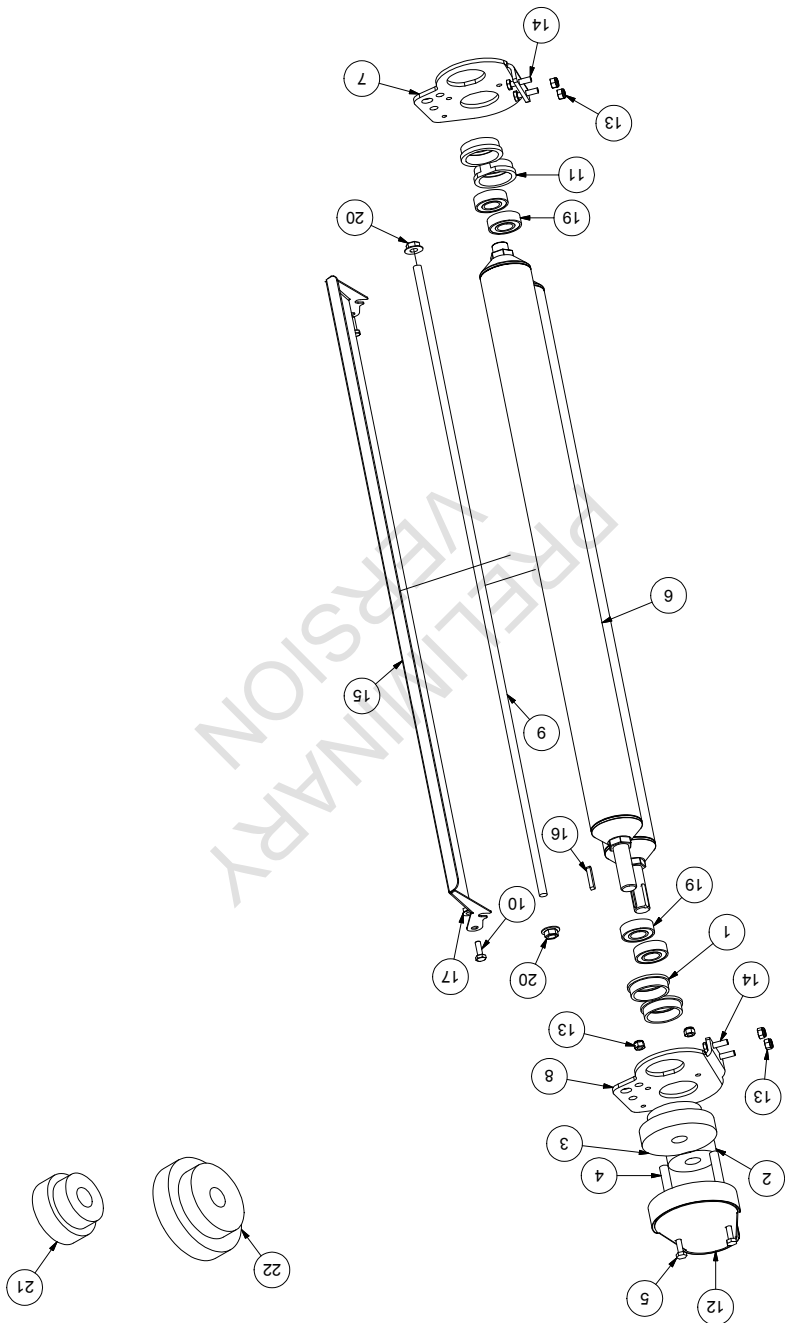



ITEM	QTY	PART	DESCRIPTION	NOTE
1	2	224067	BEARING CUP	
2	1	279102	GEAR	
3	1	279100	GEAR	
4	2	224068	SPACER	
5	2	500017	BOLT	
6	2	279004	ALUMINIUM ROLLER	
7	1	224065	LOWER BRACKET	
8	1	224066	UPPER BRACKET	
9	1	224070	ROD	
10	5	500004	BOLT	
11	2	224067	BEARING CUP	
12	1	224071	SHIELD	
13	8	501030	NYLON NUT	
14	4	500006	BOLT	
15	1	224075	PLASTIC SHIELD	
16	2	320022	KEY	
17	2	501020	FLANGE NUT	
19	4	303018	BEARING	
20	2	501022	FLANGE NUT	
21	1	279103	GEAR	
22	1	279104	GEAR	

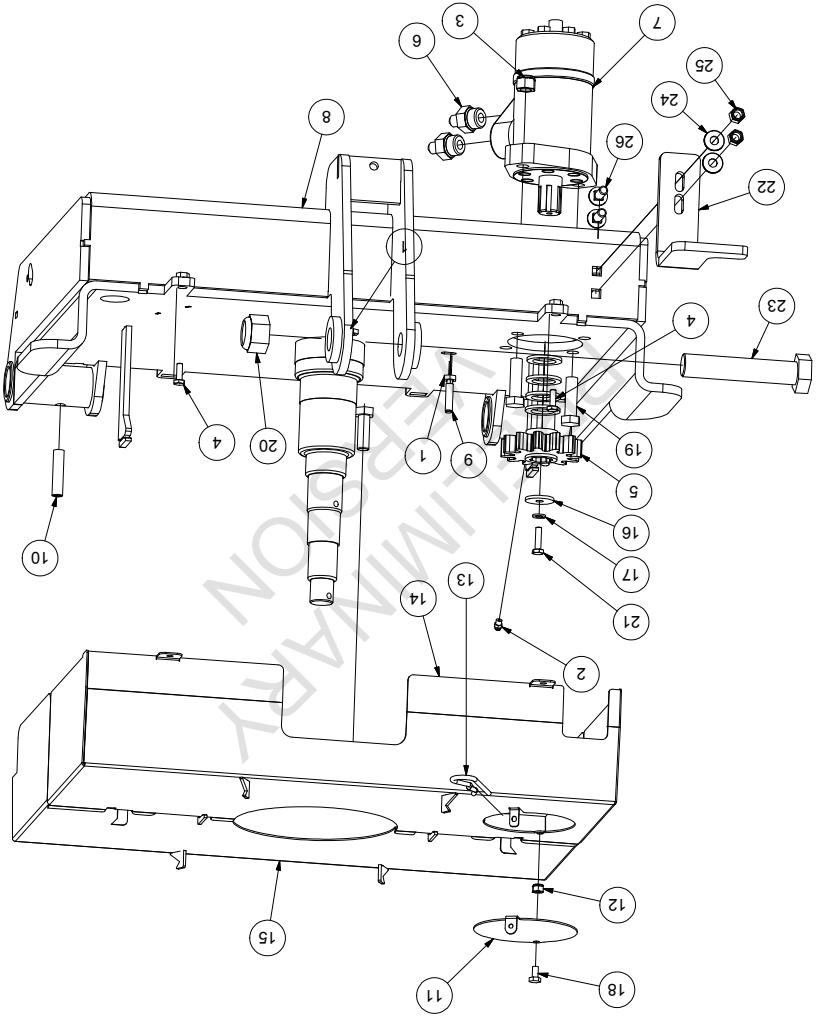

ITEM	QTY	PART	DESCRIPTION	NOTE
1	4	315007	PLASTIC NUT	
2	1	322299	GREASE FITTING	
3	2	501034	NYLON NUT	
4	2	500004	BOLT	
5	1	300513	GEAR	
6	2	451173	HYDRAULIC FITTING	
7	1	469147	HYDRAULIC MOTOR	
8	1	222005-1	TABLE	
9	1	315004	WIRED SENSOR	
10	1	320074	SPRING PIN	
11	1	223018	CAP	
12	1	501030	NYLON NUT	
13	1	320010	HITCH PIN CLIP	
14	1	222045	FRONT GUARD	
15	1	222046	REAR GUARD	
16	1	210629	WASHER	
17	1	502046	LOCK WASHER 5/16 Z	
18	1	500001	HEX BOLT GR5 1/4-20 X 1/2	
19	2	500179	HEX BOLT GR5 1/2-13 X 1 1/2	
20	1	501037	NYLON NUT	
21	1	500006	HEX BOLT GR5 1/4-20 X 1	
22	1	222053	SHUTTER	
23	1	500333	HEX BOLT GR5 1-8 X 5 Z	
24	2	502024	FLAT WASHER	
25	2	501032	NYLON NUT	
26	2	500443	CARRIAGE BOLT GR5 3/8-16 X 1 1/4 Z	

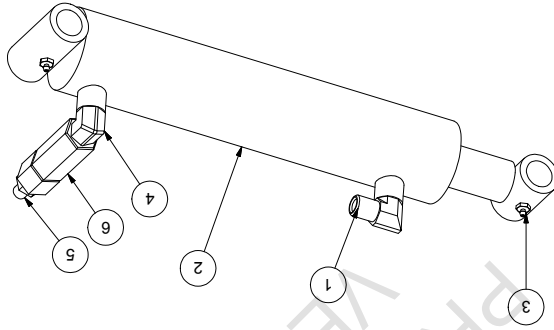

ITEM	QTY	PART	DESCRIPTION	NOTE
1	1	450712	HYDRAULIC FITTING	
2	1	467029	DOMP. TABLE CYLINDER	
3	2	322295	GREASE FITTING	
4	1	450196	HYDRAULIC FITTING	
5	1	450543	HYDRAULIC FITTING	
6	1	465878	CHECK VALVE	

7 - DUMPING TABLE

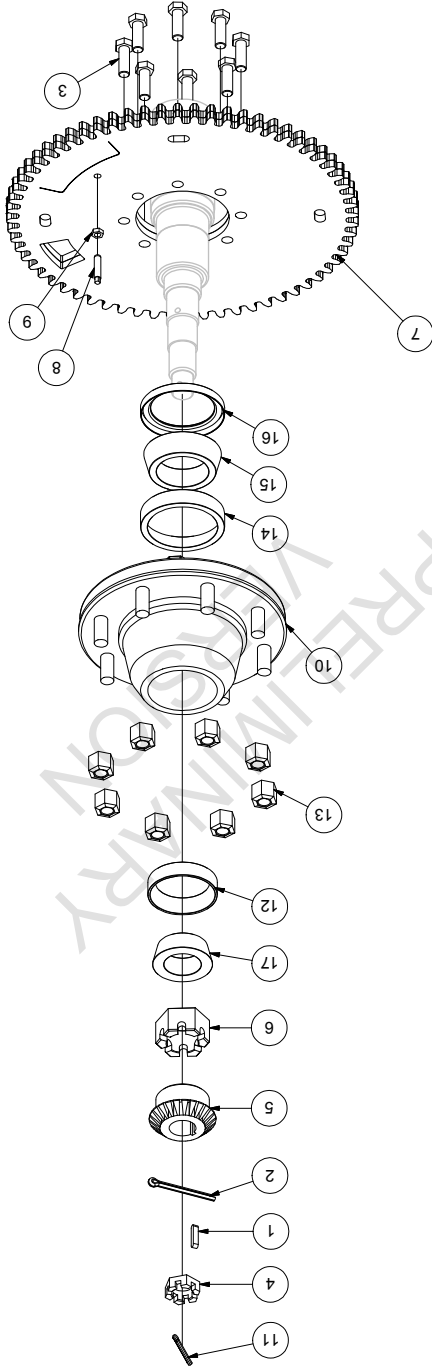



ITEM	QTY	PART	DESCRIPTION	NOTE
1	1	224036	KEY	
2	1	320017	COTTER PIN	
3	8	500211	HEX BOLT GR5 1/2-20 X 1 1/2	
4	1	501100	HEX HALF CASTLE NUT 1-12	
5	1	300509-S	CONIC GEAR	
6	1	501120	HEX CASTLE NUT 1 1/2-12	
7	1	223022-2	GEAR	
8	1	315004	SENSOR	
9	2	315007	PLASTIC NUT	
10	1	481404	HUB	
11	1	320002	COTTER PIN 3/16 X 2 Z	
12	1	303493	BEARING CUP	
13	1	501902	WHEEL NUT	
14	1	303492	BEARING CUP	
15	1	303491	BEARING	
16	1	303490	DUST CAP	
17	1	303494	BEARING	

PARTS LIST

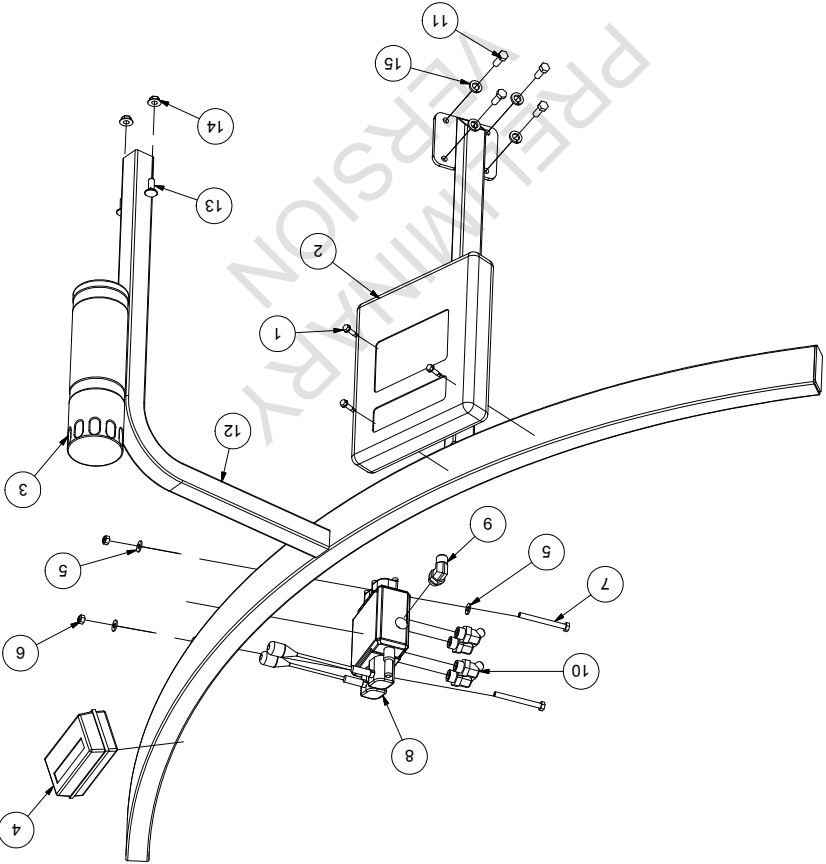

ITEM	QTY	PART	DESCRIPTION	NOTE
1	3	507006	SELF-DRILLING SCREW	
2	1	325109-1	OPERATOR'S MANUAL BOX	
3	1	325120	CYLINDER BOX	
4	1	315006	COUNTER	
5	4	502014	FLAT WASHER	
6	2	501031	NYLON NUT	
7	2	500059	BOLT	
8	1	466015	VALVE	
9	1	451265	HYDRAULIC FITTING	
10	4	451227	HYDRAULIC FITTING	
11	4	500084	BOLT	
12	1	222003	SHIELD	
13	2	500442	CARRIAGE BOLT	
14	2	501022	FLANGE NUT	
15	4	502045	LOCK WASHER	

PARTS LIST

PRELIMINARY
VERSION

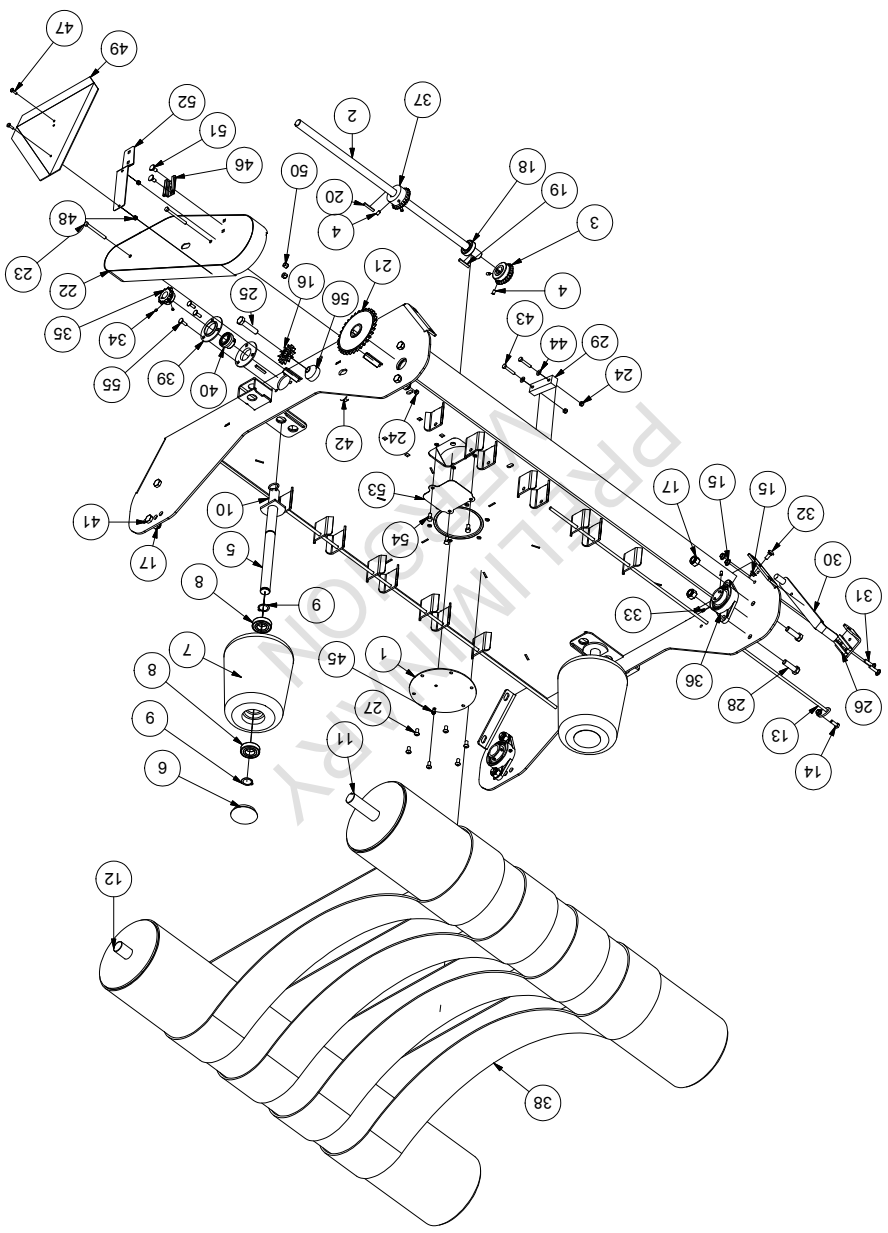

ITEM	QTY	PART	DESCRIPTION
1	1	223182	TAB
2	1	222040	ROTATING ROLL'S SHAFT
3	1	300511M1-S	GEAR
4	14	507005	HEX SOCKET SET SCREW CUP 5/16-18 X 1/2
5	2	223026	ROLLER SUPPORT STAND SHAFT
6	2	325107	PLASTIC HOLE PLUG
7	2	325112	PLASTIC ROLLER
8	4	303045	BEARING
9	4	320006	SNAP RING
10	2	320039	PIN
11	1	223039	DRIVING ROLLER
12	3	223040	DRIVERD ROLLER
13	2	230041	ROD
14	2	500084	BOLT
15	5	501022	HEX FLANGE NUT GR2 3/8-16 Z
16	1	301101	SPROCKET
17	8	501035	NYLON NUT
18	1	303989	BEARING
19	2	222015	KEY
20	1	224014	KEY
21	1	223035	SPROCKET
22	1	223042	CHAIN GARD ON PIV.TABLE
23	2	500060	HEX BOLT GR5 5/16-18 X 3 1/2
24	4	501031	NYLON NUT
25	1	502049	HEX BOLT GR5 5/8-11 X 2 3/4
26	2	222038	LOCK SUPPORT
27	6	507065	BUTTON HEAD SCREW 3/8-16 X 3/4
28	4	500246	HEX BOLT GR5 5/8-11 X 2
29	1	485576	STOPPER
30	1	222039	LOCK
31	2	500444	CARRIAGE BOLT GR5 3/8-16 X 1 1/2 Z
32	1	500442	CARRIAGE BOLT GR5 3/8-16 X 1 Z
33	4	322299	GREASE FITTING
34	2	507003	HEX SOCKET SET SCREW CUP 1/4-20 X 1/4
35	1	301050	SPROCKET
36	4	303024	BEARING
37	1	300511	GEAR
38	4	322603	BELT
39	2	303050	FLANGE BEARING
40	1	303000	BEARING SA205-16 EXCENTRIQUE
41	4	500245	BOLT
42	1	501025	FLANGE NUT
43	2	500050	HEX BOLT GR5 5/16-18 X 1 3/4
44	2	502014	FLAT WASHER 5/16 PO Z
45	1	322295	GREASE FITTING
46	1	210758	MOUNTING SUPPORT
47	2	500004	BOLT
48	2	501030	NYLON NUT
49	1	325145	SECURITY TRIANGLE
50	2	501032	NYLON NUT
51	2	500440	CARRIAGE BOLT GR5 3/8-16 X 3/4 Z
52	1	308016	TRIANGLE SUPPORT
53	1	222056	PLASTIC CUT COVER
54	3	500082	BOLT
55	3	500403	CARRIAGE BOLT GR5 5/16-18 X 1 Z
56	1	486241	

PARTS LIST

9 - ROTARY TABLE AND CUT AND HOLD



PARTS LIST			
ITEM	QTY	PART	DESCRIPTION
1	1	222006	CUT AND HOLD UPPER SECTION
2	1	222007	CUT AND HOLD BOTTOM SECTION
3	2	223049	HOLDING ROLLER
4	1	222008	ROTARY TABLE

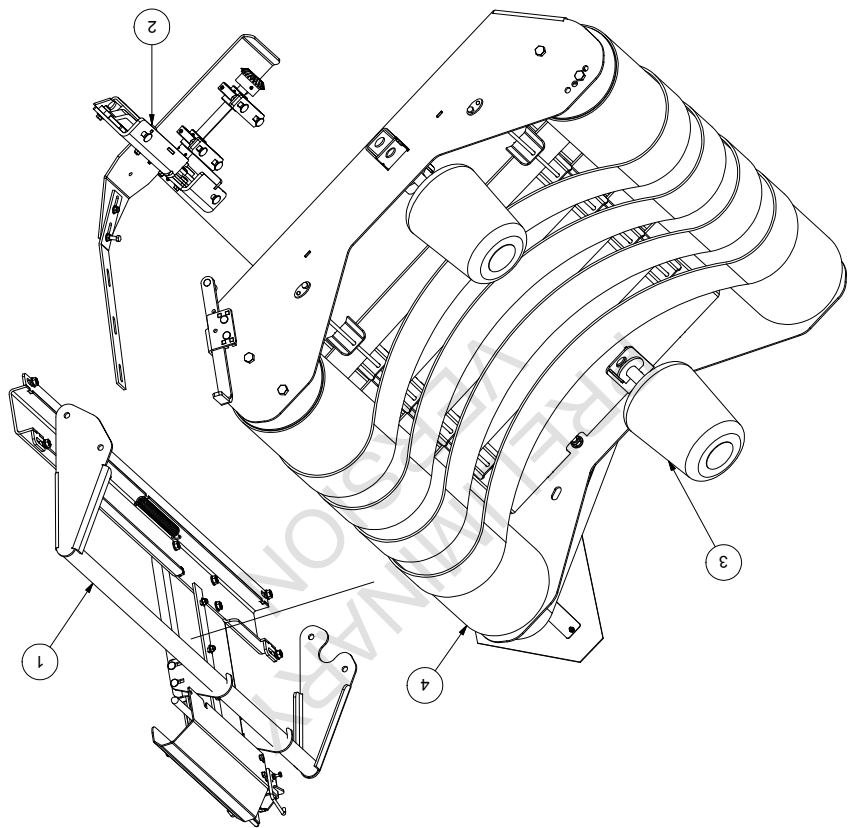

PRELIMINARY
VERSION

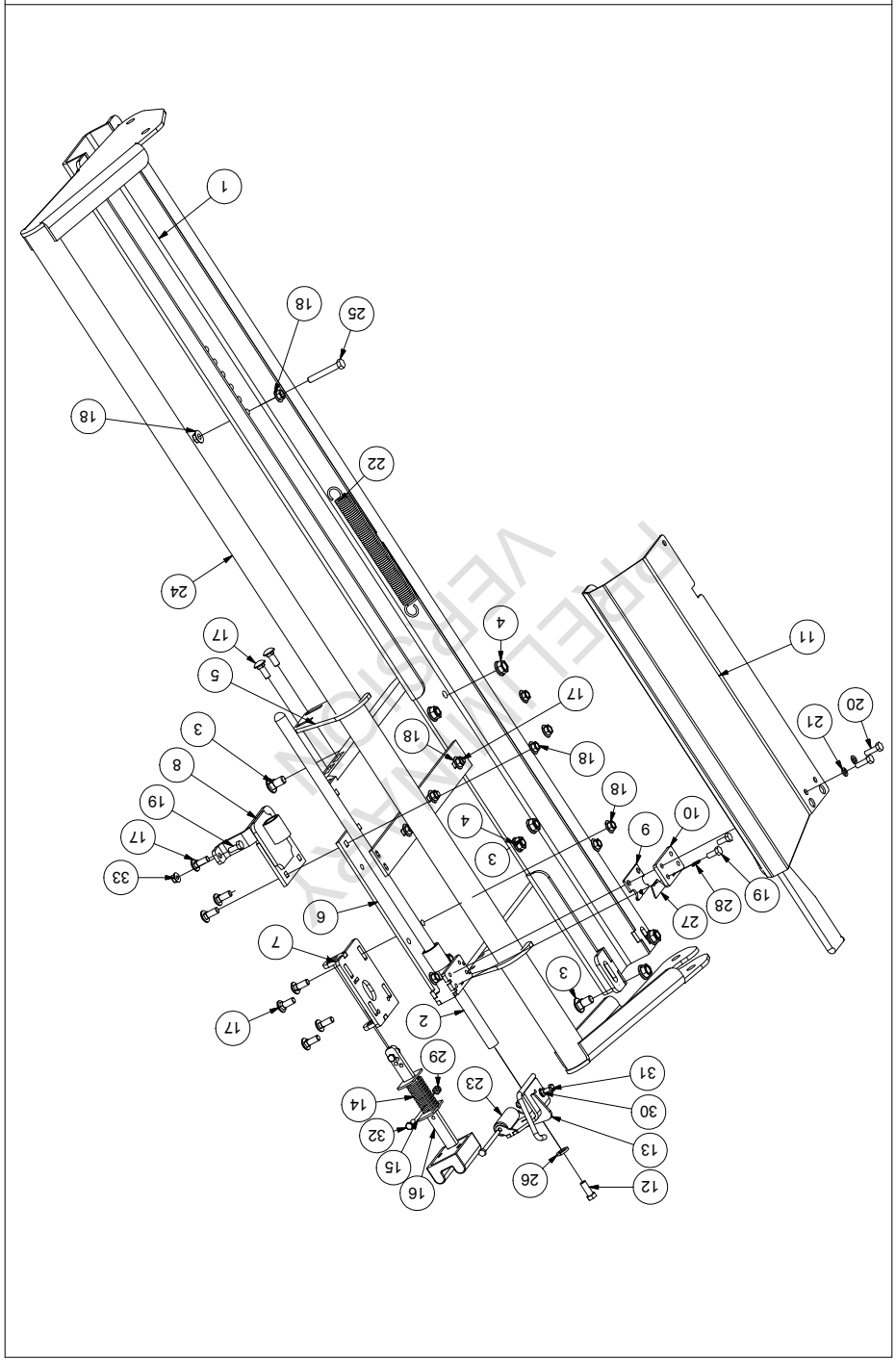

ITEM	QTY	PART	DESCRIPTION	NOTE
1	1		ATTECHEMENT PLATE	
2	1	222023	HAMMER SHAFT	
3	8	500500	CARRIAGE BOLT	
4	8	501024	FLANGE NUT	
5	2	222025	HOOK	
6	1	222037	HAMMER AND BUFFER SUPPORT	
7	1	222026	BUFFER SUPPORT	
8	1	222027	HAMMER SUPPORT	
9	1	222028	BLADE HOLDING PLATE	
10	1	222029	BLADE MOUNTING PLATE	
11	1	222030	COVER	
12	1	500084	BOLT	
13	1	222031	HAMMER'S PLATE	
14	1	304010	SPRING	
15	2	222033	SPRING'S PLATE	
16	1	222034	RUBBER BUFFER	
17	14	500442	CARRIAGE BOLT	
18	16	501022	FLANGE NUT	
19	3	500042	BOLT	
20	2	500044	BOLT	
21	2	502065	LOCK WASHER	
22	1	304012	SPRING	
23	1	222035	HAMMER'S ROLL	
24	1	238009	PLASTIC CUT SUPPORT	
25	1	500096	BOLT	
26	1	502045	LOCK WASHER	
27	1	325108	BLADE	
28	2	320050	SPRING PIN	
29	3	501030	NYLON NUT	
30	1	501020	FLANGE NUT	
31	1	500006	BOLT	
32	2	500004	BOLT	
33	1	501021	FLANGE NUT	

PARTS LIST

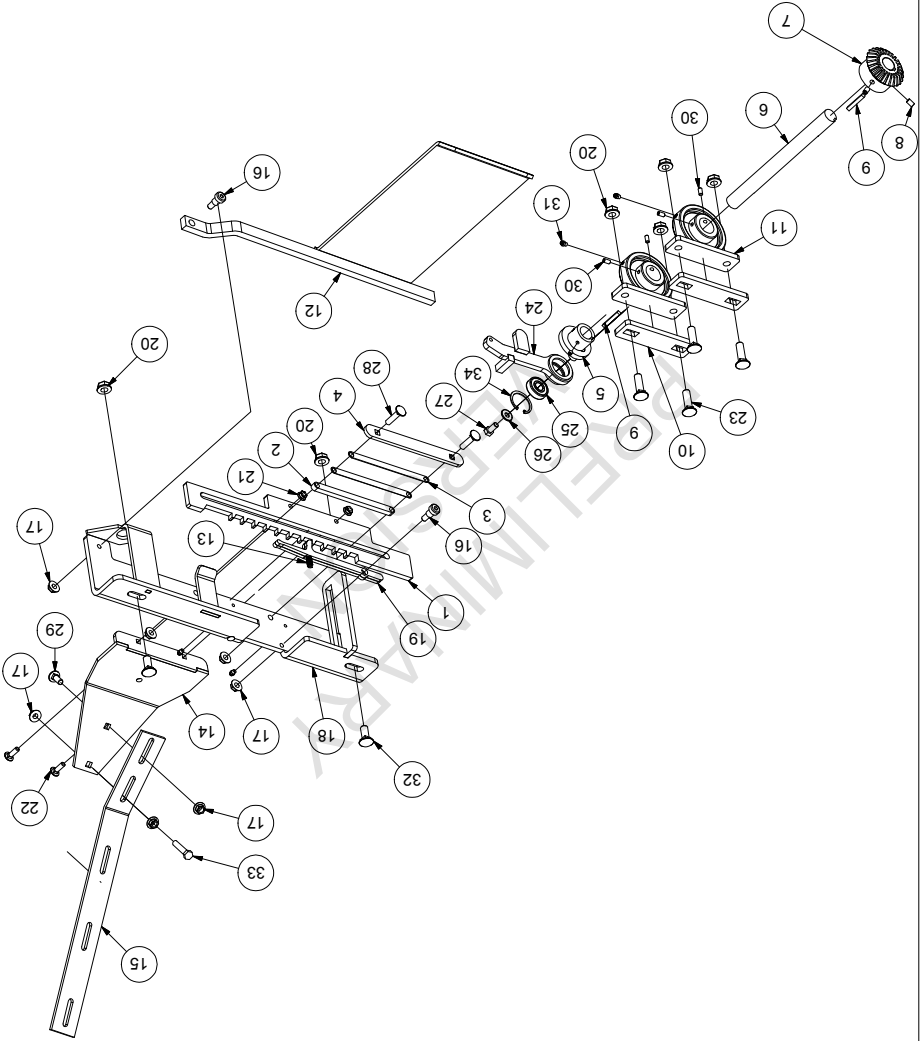

ITEM	QTY	PART	DESCRIPTION	NOTE
1	1	238008	RACK AND PINION	
2	1	222010	SPACER	
3	2	222011	SPACER	
4	1	222012	RACK AND PINION HOLDING PLATE	
5	1	222013	CAME	
6	1	222014	CAM SHAFT	
7	1	300511	GEAR	
8	2	507005	ALLEN SET SCREW	
9	2	222015	KEY	
10	2	222016	BEARING MOUNTING PLATE	
11	2	303028	BEARING	
12	1	222017	ACTIVATION PLATE	
13	1	304030	SPRING	
14	1	222018	TRANSFER PLATE	
15	1	222019	TRANSFER BRACKET	
16	2	500570	SHOULDER SCREW	
17	7	501022	FLANGE NUT	
18	1	222020	RACK AND PINION PLATE	
19	2	222021	RACK AND PINION HOOK	
20	6	501024	FLANGE NUT	
21	2	501021	FLANGE NUT	
22	2	500403	CARRIAGE BOLT	
23	4	500503	CARRIAGE BOLT	
24	1	222022	CAM FINGER	
25	1	303021-1	BEARING	
26	1	502004	FLAT WASHER	
27	1	500082	BOLT	
28	2	500444	CARRIAGE BOLT	
29	1	500442	CARRIAGE BOLT	
30	4	507003	ALLEN SET SCREW	
31	4	322299	GREASE FITTING	
32	2	500501	CARRIAGE BOLT	
33	1	500092	BOLT	
34	1	320055	RETAINING RING	

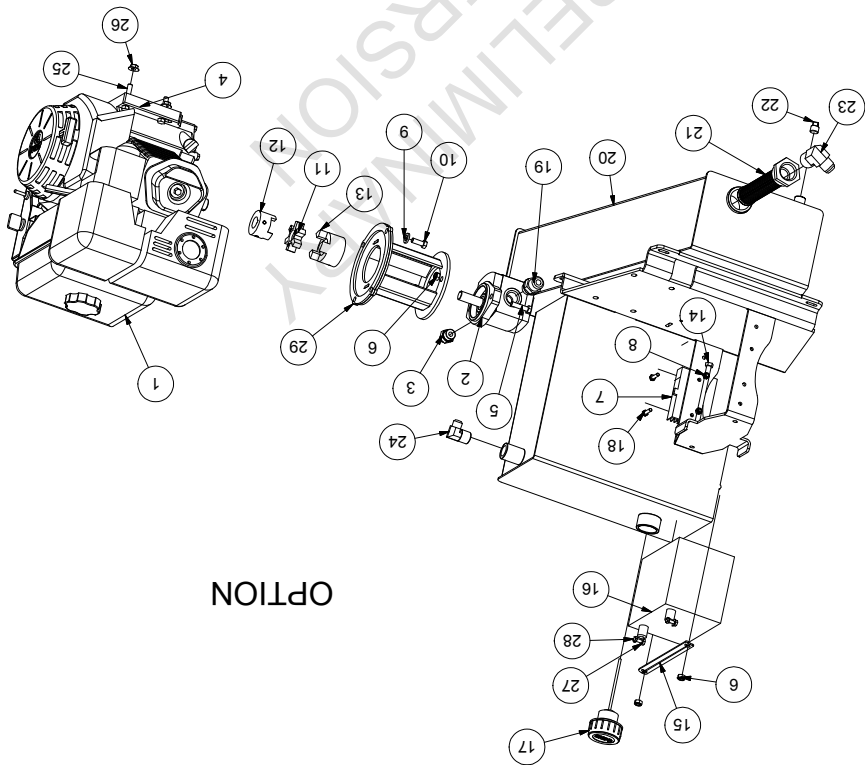

OPTION

PARTS LIST

ITEM	QTY	PART	DESCRIPTION	NOTE
1	1	605006	ENGINE	
2	1	468495-468002	PUMP	
3	1	451179	HYDRAULIC FITTING	
4	4	502004	FLAT WASHER	
5	2	500088	BOLT	
6	4	501032	NYLON NUT	
7	1	605009	VOLTAGE REGULATOR	
8	4	501030	NYLON NUT	
9	4	502045	LOCK WASHER	
10	4	500084	BOLT	
11	1	322020	INSERT	
12	1	322050	COUPLING	
13	1	322042	COUPLING	
14	2	500114	BOLT	
15	1	224110	BATTERY HOLDER	
16	1	470113	BATTERY	
17	1	470112	TANK CAP	
18	2	500006	BOLT	
19	1	451190	HYDRAULIC FITTING	
20	1	224108	TANK	
21	1	470990	STRAINER	
22	1	470117	DRAIN PLUG	
23	1	450725	HYDRAULIC FITTING	
24	4	450717	HYDRAULIC FITTING	
25	4	500092	BOLT	
26	4	501022	FLANGE NUT	
27	2	501020	FLANGE NUT	
28	2	500004	BOLT	
29	1	322008	PUMP ADAPTER	

11 - LOADING ARM



ITEM	QTY	PART	DESCRIPTION	NOTE
1	1	223058	LOCK PIN	
2	1	304010	SPRING	
3	1	322299	GREASE FITTING	
4	1	223059	OUTER FORK	
5	2	502004	FLAT WASHER	
6	4	500088	BOLT	
7	4	501032	NYLON NUT	
8	2	322299	GREASE FITTING	
9	1	223087-1	CAM	
10	1	223055	LOCK	
11	1	223056	BALE STOPPER	
12	3	500501	CARRIAGE BOLT	
13	3	501024	FLANGE NUT	
14	1	223057-1	LOADING ARM FRAME	
15	1	303052	BUSHING	

PARTS LIST

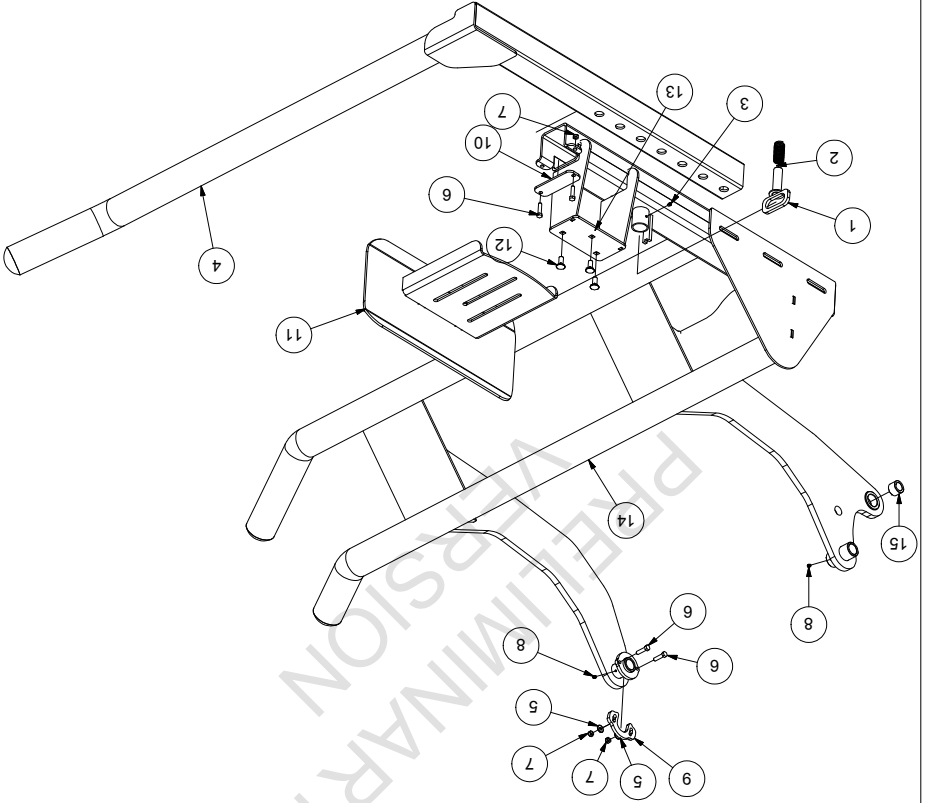

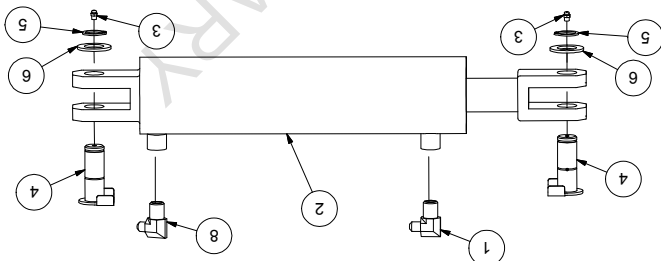

ITEM	QTY	PART	DESCRIPTION
1	1	450712	HYDRAULIC FITTING
2	1	467152	HYDRAULIC CYLINDER
3	2	322299	GREASE FITTING
4	2	223098	CYLINDER AXLE
5	2	32005-1	SNAP RING
6	2	223099	WASHER
7	1	450712M	HYDRAULIC FITTING
NOTE			

PARTS LIST

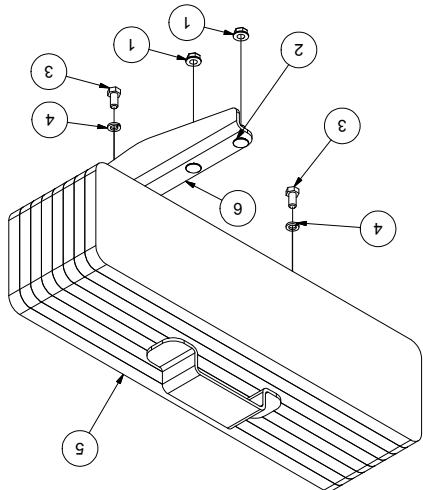

ITEM	QTY	PART	DESCRIPTION
1	2	501024	FLANGE NUT
2	2	500501	CARRIAGE BOLT
3	2	500173	BOLT
4	2	502048	LOCK WASHER
5	1	223083	COUNTERWEIGHT
6	1	223082	SUPPORT
NOTE			

PARTS LIST

ITEM	QTY	PART	DESCRIPTION	NOTE
1	1	223060	REAR ATTACHMENT	
2	1	501024	FLANGE NUT	
4	2	500501	CARRIAGE BOLT	
5	1	223061	PIN	
6	1	320010	LOCK	
7	7	501024	FLANGE NUT	
8	1	501032	NYLON NUT	
9	1	500096	BOLT	
15	5	500504	CARRIAGE BOLT	

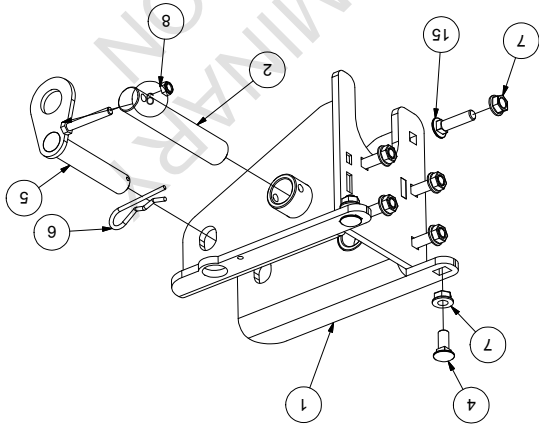

ITEM	QTY	PART	DESCRIPTION	NOTE
1	1	223063	FRONT ATTACHMENT	
2	1	223066	PIN	
3	6	500502	CARRIAGE BOLT	
4	1	502004	FLAT WASHER	
5	1	223065	LEVER	
6	1	223064	SPACER	
7	6	501024	FLANGE NUT	
8	1	500096	BOLT	
9	3	501032	NYLON NUT	
10	2	500088	BOLT	

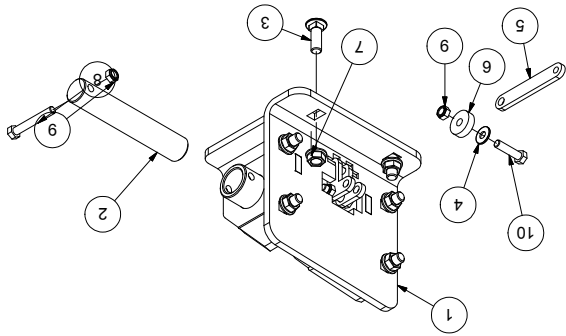



ITEM	QTY	PART	DESCRIPTION	NOTE
2	1	451230	HYDRAULIC FITTING	
3	1	465918	HYDRAULIC VALVE	
4	6	451226	HYDRAULIC FITTING	
5	3	465492	VALVE PIECE CABLE	
6	1	465490	CABLE	
6	1	451229	HYDRAULIC FITTING	

PARTS LIST

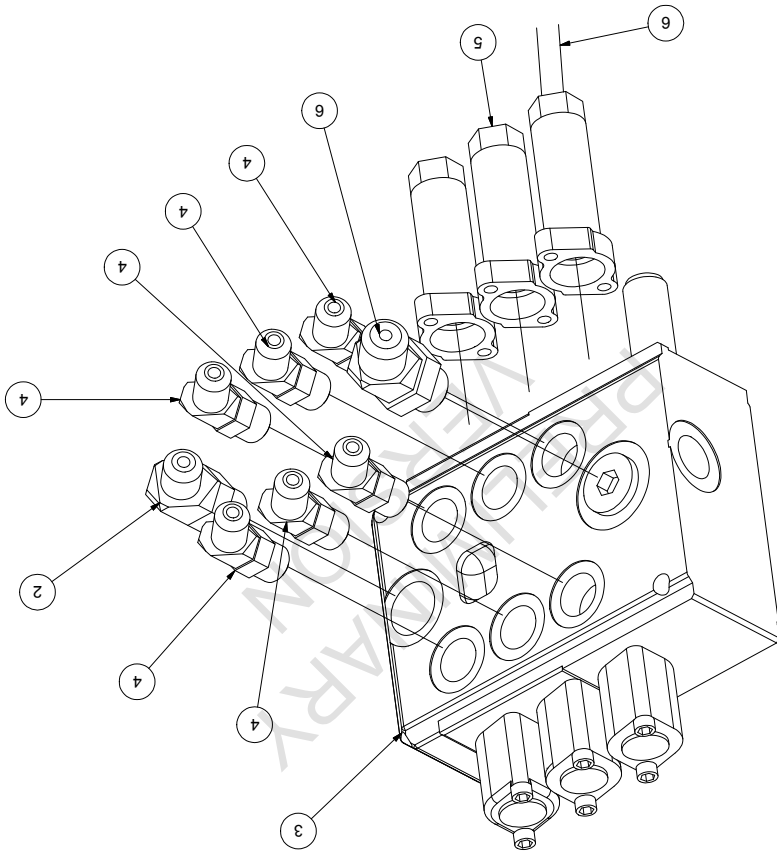

ITEM	QTY	PART	DESCRIPTION	NOTE
1	3	465494	CABLE CONTROL	
2	1	222048	CONTROL CABLE ATTACHMENT	
3	1	222049	CONTROL PLATE	
4	2	222050	PLATE ATTACHMENT	
5	1	210758	ASSEMBLY SUPPORT	
6	2	500403	CARRIAGE BOLT	
7	4	502065	LOCK WASHER	
8	2	501001	NUT	
9	6	507064	BUTTON HEAD SCREW	
10	6	501049	NYLON NUT	
11	6	501077-1	BOLT	
12	2	500044	BOLT	
13	4	502014	FLAT WASHER	
14	1	222051	COMPLETE CONTROL KIT	

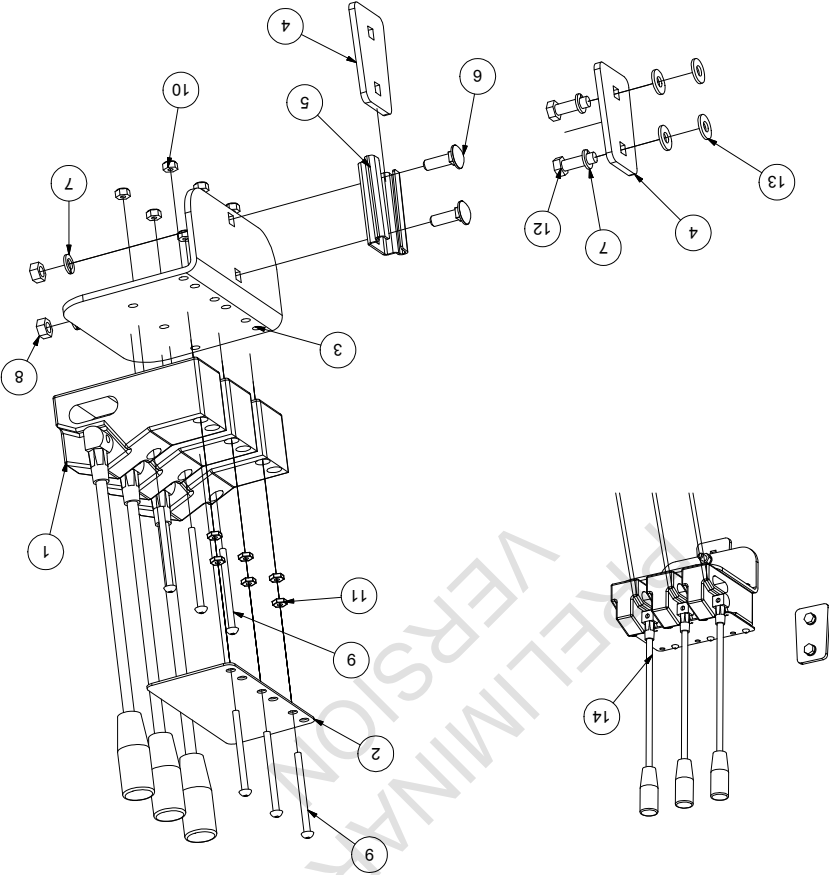

12 - DOUBLE PLASTIC ROLL

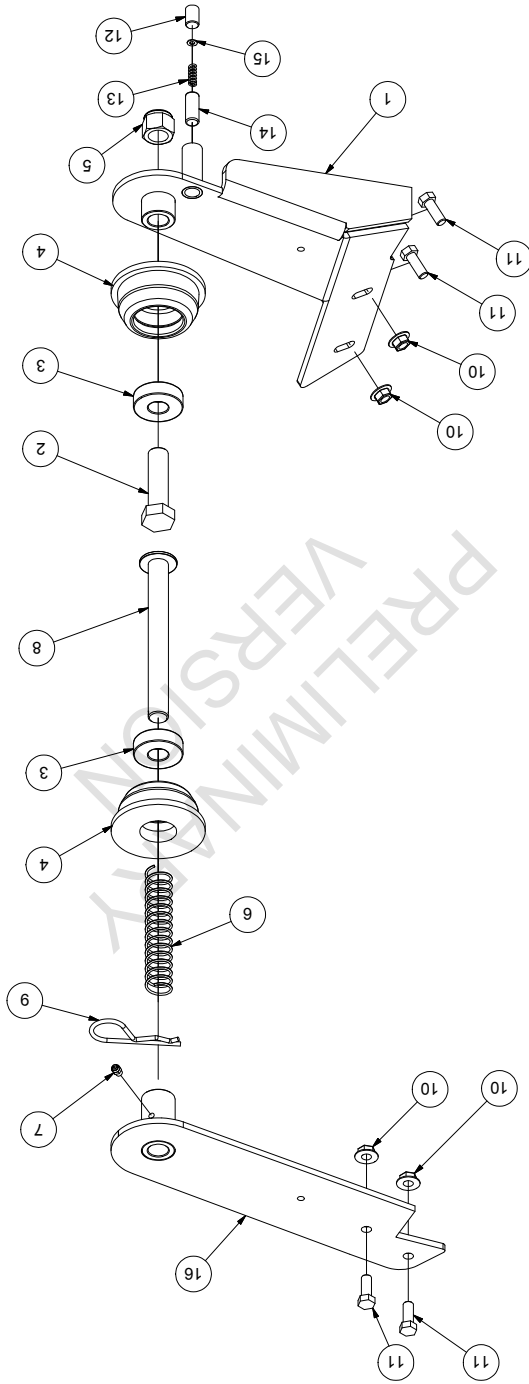



ITEM	QTY	PART	DESCRIPTION	NOTE
1	1	224214	LOWER SUPPORT	
2	1	500288	HEX BOLT GR5 3/4-10 X 2 3/4	
3	2	303012	BEARING 6204RS-750	
4	2	224082	ROLLER SUPPORT	
5	1	501036	NYLON NUT	
6	1	304009	SPRING	
7	1	322299	GREASE FITTING	
8	1	224077	SHAFT	
9	1	320039	HITCH PIN 5/32 X 3 5/16	
10	4	501022	HEX FLANGE NUT GR2 3/8-16 Z	
11	4	500084	BOLT	
12	1	507036	HEX SOCKET SET SCREW CUP 1/2-13 X 3/4	
13	1	304023	SPRING	
14	1	224081	BRAKE TEFLON	
15	1	502001	FLAT WASHER	
16	1	224215	HIGHER SUPPORT	

PARTS LIST

13 - DROP OFF

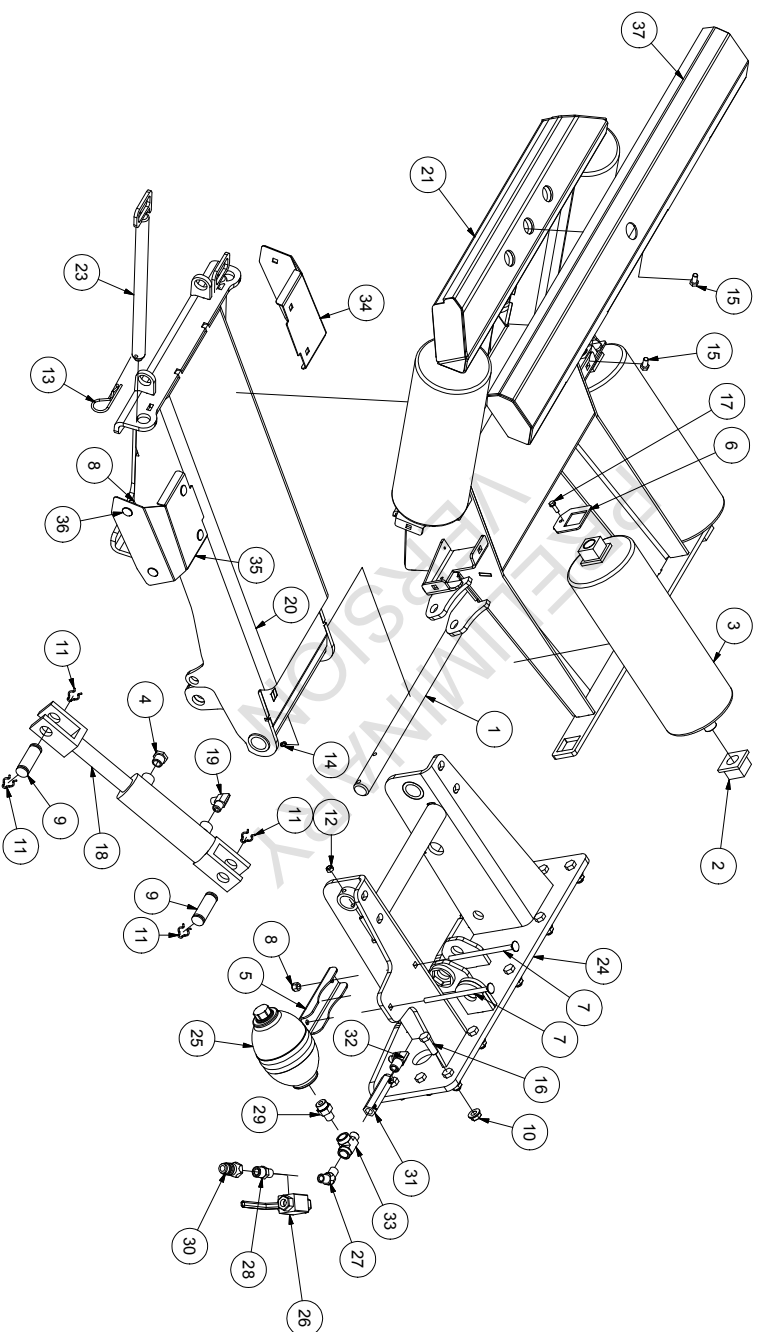

13 - DROP OFF



PARTS LIST				PARTS LIST			
ITEM	QTY	PART	DESCRIPTION	ITEM	QTY	PART	DESCRIPTION
1	1	223094	DROP OFF AXLE	20	1	223089-1	DROP OFF PLATE
2	8	279001	BUSHING	21	1	223090-2	TABLE
3	4	210523	ROLLER	22	1	223090	TABLE
4	1	470993	HYDRAULIC FITTING	23	2	223091-1	TABLE AXLE
5	1	223008	SUPPORT	24	1	223088-1	DROP OFF ATTACHMENT
6	4	210521	ROLLER LOCK	25	1	470108	ACCUMULATOR
7	2	500485	CARRIAGE BOLT GR5 3/8-16 X 6 1/2 Z	26	1	466999-1	HYDRAULIC VALVE
8	6	501032	NYLON NUT	27	1	450132	6 M NPT - 6 M NPT 45°
9	2	467500	CYLINDER PIN	28	1	450007	8 M NPT - 6 M NPT
10	26	501024	HEX FLANGE NUT GR2 1/2-13 Z	29	1	451094	8 M ORB - 6 M NPT
11	4	467501	HAIR PIN COTTER 1 PO	30	1	452000	HYDRAULIC FITTING
12	1	501031	NYLON NUT	31	1	465051	DOUBLE RELIEF VALVE
13	5	320039	HITCH PIN 5/32 X 3 5/16	32	1	450712	HYDRAULIC FITTING
14	4	322299	GREASE FITTING	33	1	450272	6 F NPT - 6 M NP
15	2	500082	BOLT	34	1	223194	LEFT GUARD
16	18	500177	BOLT	35	1	223193	RIGHT GUARD
17	4	507039-1	HEX SELF-THREADING SCREW 1/4-20 X 1/2 ST-647H	36	4	500440	CARRIAGE BOLT GR5 3/8-16 X 3/4 Z
18	1	467098	HYDRAULIC CYLINDER	37	1	223305	TABLE COVER
19	1	450711	HYDRAULIC FITTING				

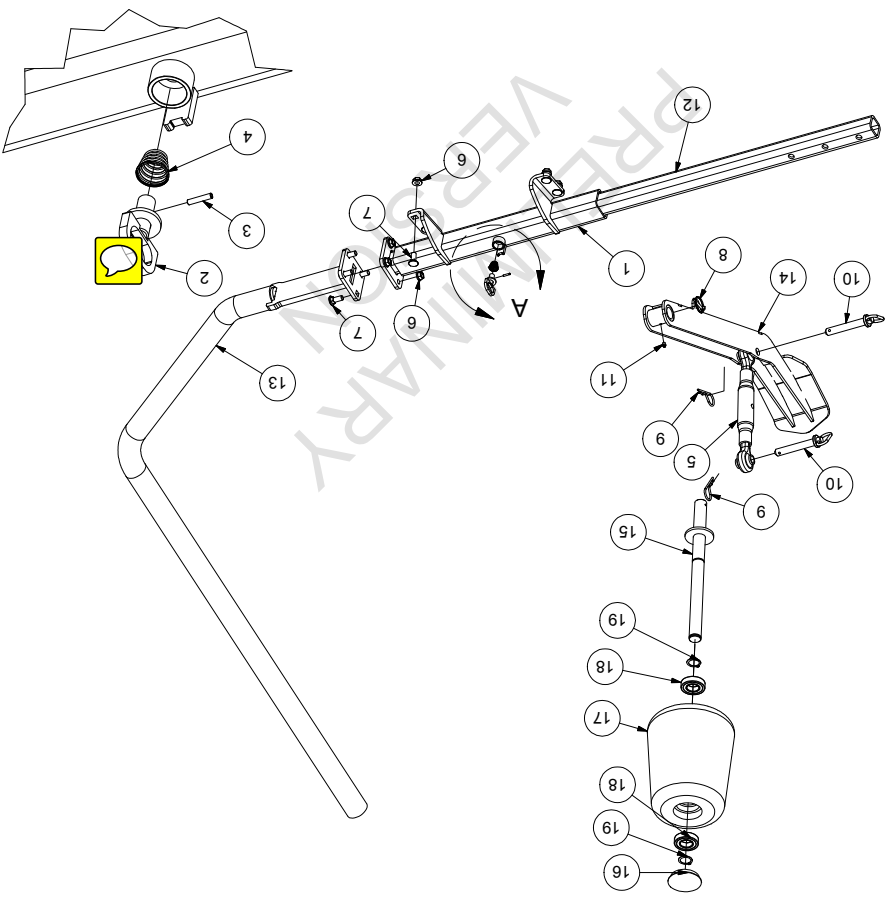

DETAIL A

PARTS LIST

ITEM	QTY	PART	DESCRIPTION
1	1	223093	ARM SUPPORT
2	1	223185	ARM LOCK
3	1	320073	SPRING PIN
4	1	304034	SPRING
5	1	224175	TOP LINK
6	26	501024	HEX FLANGE NUT GR2 1/2-13 Z
7	8	500501	CARRIAGE BOLT GR5 1/2-13 X 1 1/4 Z
8	1	320007	LINCHPIN
9	5	320039	HITCH PIN 5/32 X 3 5/16
10	2	320082	TOP LINK PIN
11	4	322299	GREASE FITTING
12	1	223183	FIXED PART OF ARM
13	1	223184	REMOVABLE PART OF ARM
14	2	223186-1	OUTRIGGER
15	1	223187	ROLLER SUPPORT AXLE
16	1	326107	CAP
17	1	326112	ROLLER SUPPORT
18	2	303045	BEARING 1654-Z
19	2	320006	RETAINING RING

NOTE



ITEM	QTY	PART	DESCRIPTION	NOTE
1	1	223222	TABLE AXLE	
2	1	223223	TABLE	
3	9	500502	CARRIAGE BOLT GR5 1/2-13 X 1 1/2 Z	
4	9	501024	HEX FLANGE NUT GR2 1/2-13 Z	
5	4	501032	NYLON NUT	
6	1	223224	DROP OFF ATTACHMENT	
7	1	467098	HYDRAULIC CYLINDER	
8	1	450711	HYDRAULIC FITTING	
8	1	470993-2	REINFLARD	
10	1	470108	ACCUMULATOR	
11	1	466999-1	HYDRAULIC VALVE	
12	1	450132	6 M.NPT - 6 M.NPT 45°	
13	1	450007	8 M.NPT - 6 M.NPT	
14	1	451094	8 M.ORB - 6 M.NPT	
15	1	452000	HYDRAULIC FITTING	
16	1	465051	DOUBLE RELIEF VALVE	
17	1	450712	HYDRAULIC FITTING	
18	1	450272	6 F.NPT - 6 M.NP	
19	1	223008	BRACKET SUPPORT	
20	2	500113	BOLT	

PARTS LIST

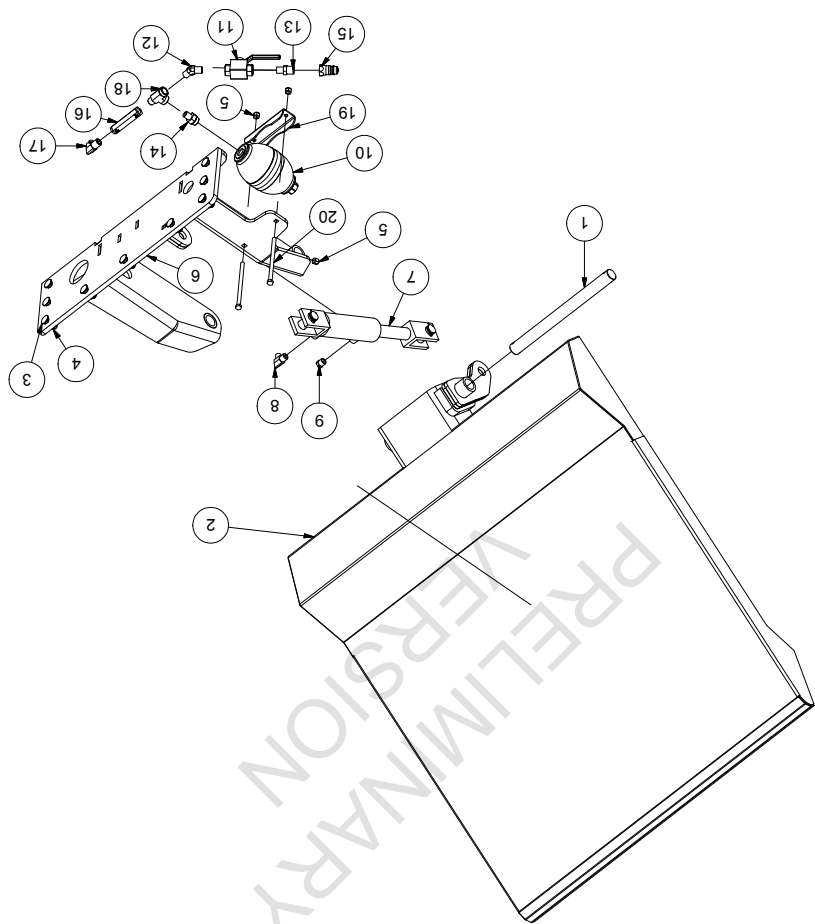



ITEM	QTY	PART	DESCRIPTION	NOTE
1	5	500334	BOLT	
2	2	223170	REAR STABILIZER	
3	1	500333	BOLT	
4	7	501057	HALF NYLON NUT	
5	4	322299	GREASE FITTING	
6	2	223171	FRONT STABILIZER	
7	1	223172	REAR STABILIZER SUPPORT	
8	14	501024	FLANGE NUT	
9	14	500500	CARRIAGE BOLT	
10	2	223179	FRONT STABILIZER SUPPORT	
11	2	467026	CYLINDER	
12	1	500330	BOLT	
13	4	450712	HYDRAULIC FITTING	
14	4	322296	GREASE FITTING	
15	1	223180	STABILIZER'S CYLINDER LOCK PIN	
16	1	320043	COTTER PIN	

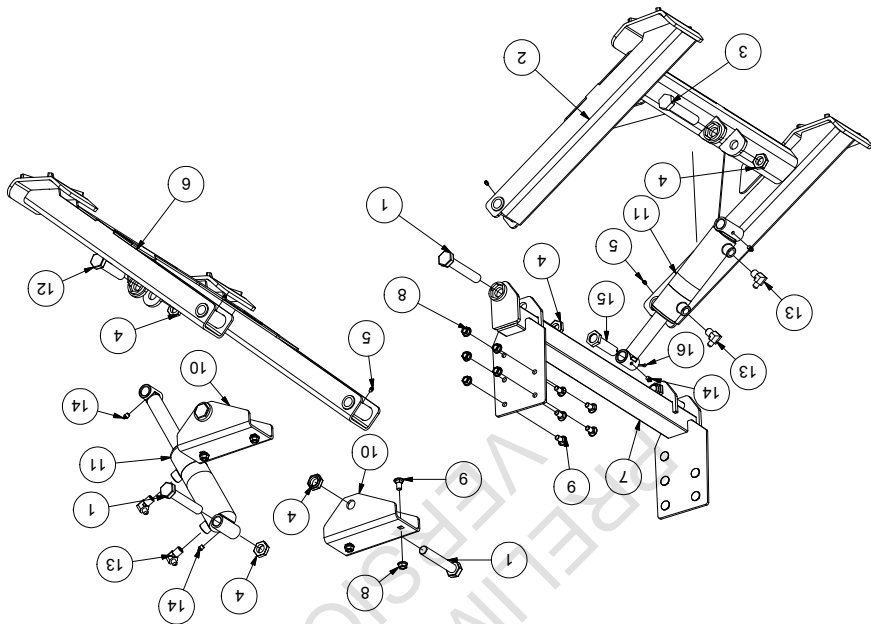

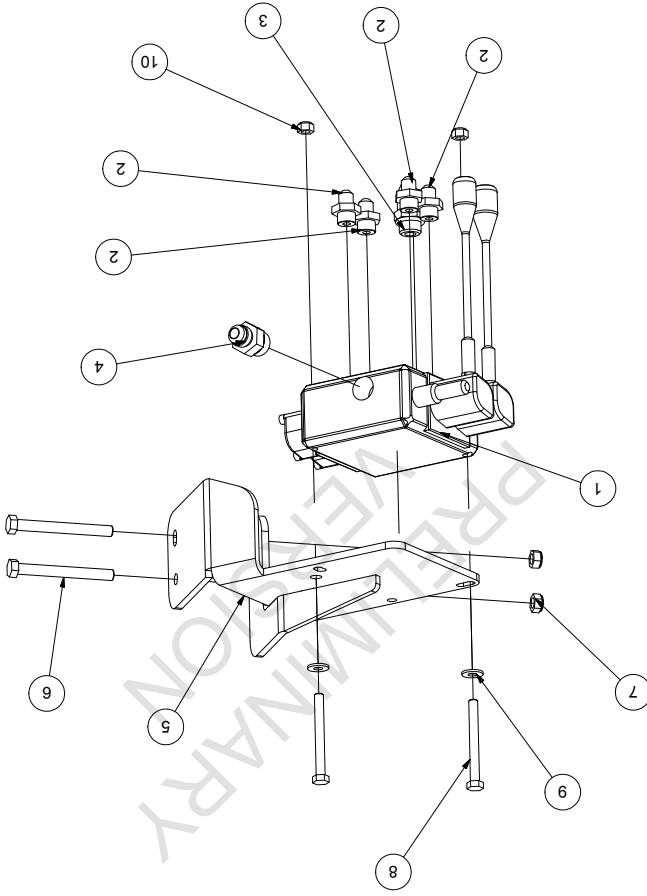

ITEM	QTY	PART	DESCRIPTION	NOTE
1	1	465901	HYDRAULIC VALVE	
2	4	451172	HYDRAULIC FITTING	
3	1	451265	HYDRAULIC FITTING	
4	1	451179	HYDRAULIC FITTING	
5	1	222047	VALVE SUPPORT	
6	2	500102	BOLT	
7	2	501032	NYLON NUT	
8	2	500058	BOLT	
9	2	502023	FLAT WASHER	
10	2	501031	NYLON NUT	

15 - DIAGRAMME HYDRAULIQUE 580 / 580 D 580M / 580 MD HYDRAULIC DIAGRAM



CYLINDRE DE TABLE BASCULANTE
DUMPING TABLE CYLINDER

VALVE 2 SECTIONS
2 SECTIONS VALVE

RACCORD RAPIDE MÂLE 1/2
MALE QUICK COUPLER 1/2
ACCUMULATEUR
ACCUMULATOR
VALVE À BILLE
BALL VALVE
3369-6-6
3759-6-6
VALVE VONBERG
#22089
3249-8-6

CYLINDRE DU POMPEUR
DROP-OFF CYLINDER

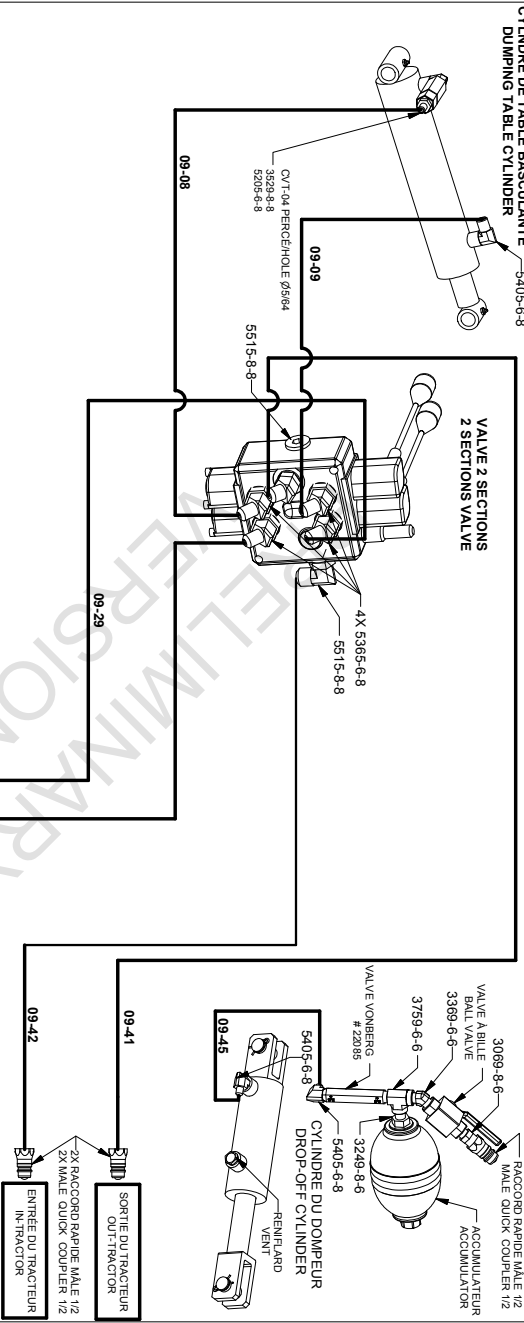

MOTEUR DE TABLE ROTANTE
ROTARY TABLE MOTOR

VALVE DÉVIA. TABLE BASCULANTE
DIVERTER VALVE TILTING TABLE

LIMITEUR DE PRESSION
RELIEF VALVE

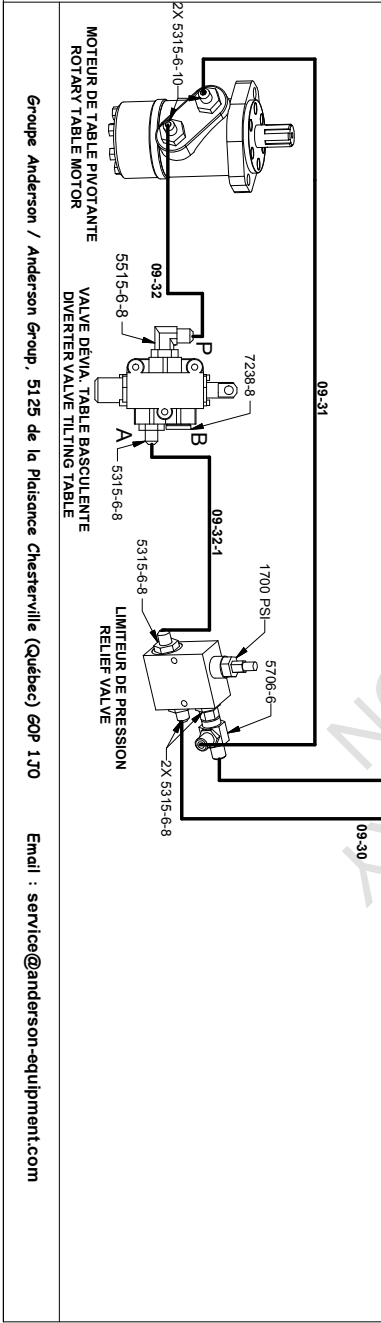

15 - DIAGRAMME HYDRAULIQUE 580 ML / 580 MLD 580 L / 580 LD HYDRAULIC DIAGRAM



CYLINDRE DE TABLE BASCULANTE
DUMPING TABLE CYLINDER

5405-6-8
3759-6-8
5205-6-8

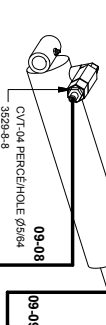

CYLINDRE DU BRAS DE CHARGEMENT
LOADING ARM CYLINDER

5405-6-8
3759-6-8
3769-6-8
PERCE-COULE #2032

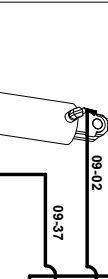

VALVE 4 SECTIONS
4 SECTIONS VALVE

LA VALVE EST PLACÉE DE COTÉ ET
LES MANÈTTES VERS L'INTERIEUR
DE LA MACHINE
THE VALVE IS MOUNTED ON
THE SIDE AND THE LEVERS TOWARDS
THE INSIDE

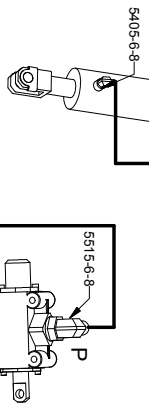
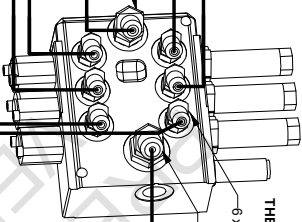

5515-6-8
VALVE DÉVIA. BRAS DE CHARG.
DIVERTER VALVE LOADING ARM

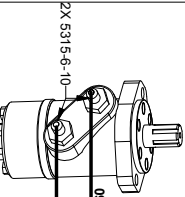

MOTEUR DE TABLE BASCULANTE
ROTARY TABLE MOTOR

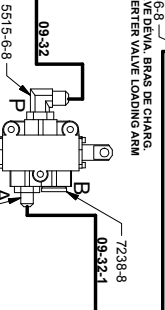

VALVE DÉVIA. TABLE BASCULANTE
DIVERTER VALVE TILTING TABLE

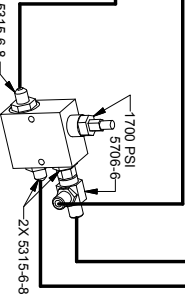

LIMITEUR DE PRESSION
RELIEF VALVE

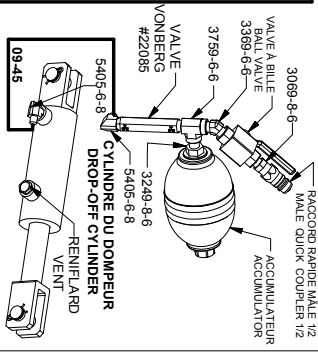

CYLINDRE DU DONDREUR
DROP-OFF CYLINDER

3069-8-6
VALVE À BILLE
VALVE
3369-6-6
3759-6-6
VALVE
#22085
VONBERG
3249-8-6
5405-6-8
5405-6-8

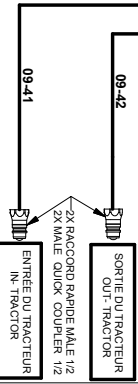

2X RACCORD RAPIDE MÂLE 1/2
2X MALE QUICK COUPLER 1/2

ENTRÉE DU TRACTEUR
IN. TRACTOR

09-41

09-42

SORTIE DU TRACTEUR
OUT. TRACTOR

09-30

09-33

7238-8

5515-6-8

2X 5315-6-10

09-34

5515-6-8

5315-6-8

5315-6-8

1700 PSI
5706-6

2X 5315-6-8

09-29

09-32-1

09-32

09-34

09-41

09-42

09-45

09-46

09-47

09-48

09-49

09-50

09-51

09-52

09-53

09-54

09-55

09-56

09-57

09-58

09-59

09-60

09-61

09-62

09-63

09-64

09-65

09-66

09-67

09-68

09-69

09-70

09-71

09-72

09-73

09-74

09-75

09-76

09-77

09-78

09-79

09-80

09-81

09-82

09-83

09-84

09-85

09-86

09-87

09-88

09-89

09-90

09-91

09-92

09-93

09-94

09-95

09-96

09-97

09-98

09-99

09-100

09-101

09-102

09-103

09-104

09-105

09-106

09-107

09-108

09-109

09-110

09-111

09-112

09-113

09-114

09-115

09-116

09-117

09-118

09-119

09-120

09-121

09-122

09-123

09-124

09-125

09-126

09-127

09-128

09-129

09-130

09-131

09-132

09-133

09-134

09-135

09-136

09-137

09-138

09-139

09-140

09-141

09-142

09-143

09-144

09-145

09-146

09-147

09-148

09-149

09-150

09-151

09-152

09-153

09-154

09-155

09-156

09-157

09-158

09-159

09-160

09-161

09-162

09-163

09-164

09-165

09-166

09-167

09-168

09-169

09-170

09-171

09-172

09-173

09-174

09-175

09-176

09-177

09-178

09-179

09-180

09-181

09-182

09-183

09-184

09-185

09-186

09-187

09-188

09-189

09-190

09-191

09-192

09-193

09-194

09-195

09-196

09-197

09-198

09-199

09-200

09-201

09-202

09-203

09-204

09-205

09-206

09-207

09-208

09-209

09-210

09-211

09-212

09-213

09-214

09-215

09-216

09-217

09-218

09-219

09-220

09-221

09-222

09-223

09-224

09-225

09-226

09-227

09-228

09-229

09-230

09-231

09-232

09-233

09-234

09-235

09-236

09-237

09-238

09-239

09-240

09-241

09-242

09-243

09-244

09-245

09-246

09-247

09-248

09-249

09-250

09-251

09-252

09-253

09-254

09-255

09-256

09-257

09-258

09-259

09-260

09-261

09-262

09-263

09-264

09-265

09-266

09-267

09-268

09-269

09-270

09-271

09-272

09-273

09-274

09-275

09-276

09-2

15 - DIAGRAMME HYDRAULIQUE 580M / 580 MD AVEC UNITÉ DE PUISSANCE 580 / 580 D WITH POWER UNIT HYDRAULIC DIAGRAM

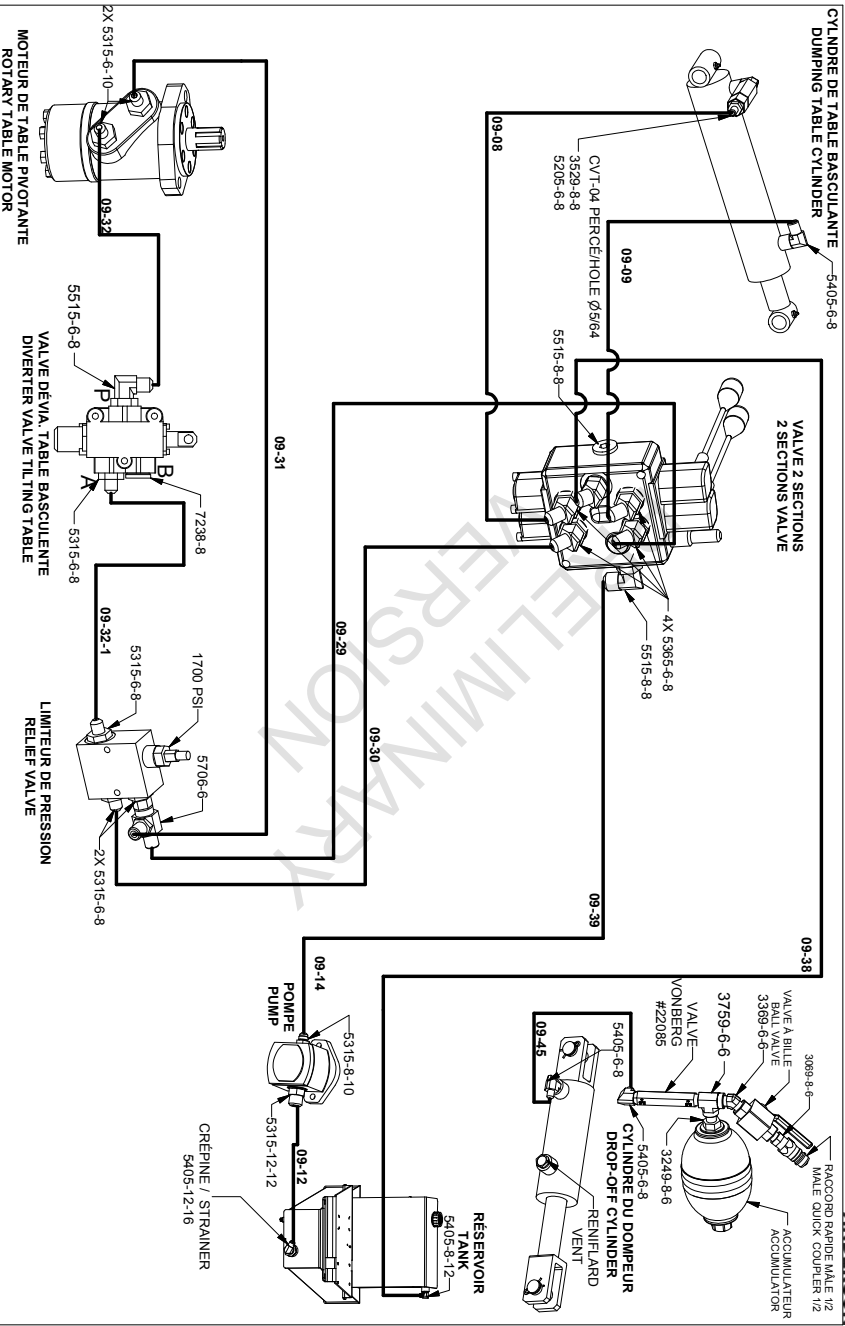

15 - LISTE DE BOYAUX / HOSE LIST



DESCRIPTION	LISTE DE BOYAUX / HOSE LIST NUMÉRO / NUMBER	NOTE
09-02	223102-1	
09-08	223108-1	
09-09	223109-1	
09-12	223158-1	
09-13	223113	
09-14	223159	
09-16	223116	
09-24	223124-1	
09-25	223125	
09-26	223126-1	
09-27	223127-1	
09-28	223128-1	
09-29	223129-1	
09-30	223130-1	
09-31	223131	
09-32	223132	
09-32-1	223132-1	
09-33	223133	
09-34	223134	
09-37	223137-1	
09-40	223140	
09-41	223141-1	
09-42	223142-1	
09-45	223178-1	