

#404611-2

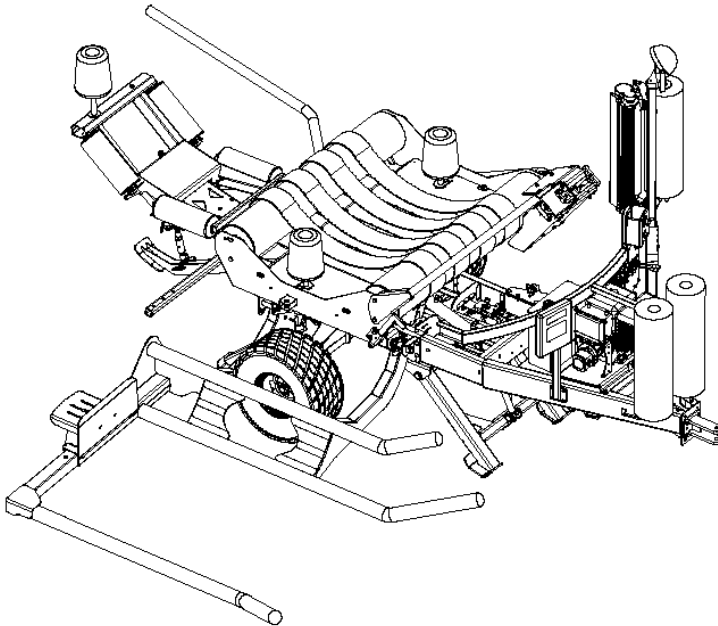

**Round Bale Wrapper
RB 580**



**Operator's Manual
2011**

For safe and proper functioning please:

1. Read the manual.
2. Follow the safety instructions.
3. Follow the start-up steps given on the last page of your manual.
4. In case of sale or transfer, give this manual to the new owner.

The illustrations in this manual are presented for your reference according to the latest information available at the moment of printing. ANDERSON EQUIPMENT reserves the right to modify its machines without advance notice.

Table of Contents

1 ANDERSON Limited Warranty.....	8
One-Year Limited Warranty.....	8
Documents	8
Problem Resolution	8
Modifications.....	8
Warranty Exemptions	10
Exclusive Remedy	10
2 Safety.....	11
Safe Operators.....	11
Danger Zone.....	11
Secure Attachment to the Tractor	11
Dangerous Situations	11
Prevention	11
Safe Maintenance and Repair.....	11
Fuel.....	12
Hydraulic Oil	12
Travelling Safely on Public Roads	12
End of Operation.....	13
3 General Characteristics and Specifications.....	14
General Specifications	15
4 Adjustment Procedures.....	16
Verifications Before Each Use.....	16
Installing the Plastic Film Roll.....	16
Testing the Plastic Film Stretcher	17
Adjusting the Two Support Rollers	17
5 Operating Procedures	18
5.1 Moving the Bale Wrapper	18
Short and Medium Distances.....	18
Safety Measures.....	18
5.2 Using the IG-C3 Bale Counter.....	18
Characteristics	18
Advanced Menu of the IG-C3 Bale Counter	19
5.3 Start and End Wrapping.....	19
Start-Up	19
Levers	20
First Bale	20
Unloading and Second Bale.....	20
End Bale Wrapping.....	20
5.4 Bale Wrapping: Adjusting the Sensors	21
Adjusting the Rotation Counter Sensor	21
5.5 Adjusting the Mechanical Plastic Film Cutter.....	21
6 Maintenance Procedures	23
Maintenance	23
Grease Gun Lubrication	23
Other Lubrication Points	27
Cleaning and Other Maintenance.....	28
Storage	29
7 Troubleshooting: Problems and Solutions.....	30
8 Optional Equipment.....	32
Hydraulic Unit	32
Electric starter with 18 amp. alternator and work light.....	32
Stabilizers.....	33

Modifying Gears to Reduce Stretch Ratio	33
Bale Loading Arm and Film Roll Support	33
Bale Unloading Platform (D).....	34
Unloading Platform (D3)	35
Double Roll Plastic Unit.....	39
9 Start-Up Procedures	40

List of Illustrations

Figure 2.1 Lock of the turntable	12
Figure 2.2 Closing the fuel valve	13
Figure 3.1 Components of the wrapper.....	14
Figure 3.2 Exterior dimensions for the base model	15
Figure 3.3 Exterior dimensions for model with optional.....	15
Figure 4.1 Installing the film roll.....	16
Figure 4.2 Direction of film unwinding	17
Figure 4.3 Adjusting the support rollers	17
Figure 5.1 Bale counter screen.....	18
Figure 5.2 580 Levers.....	20
Figure 5.3 Rotation counter sensor.....	21
Figure 5.4 Plastic film cutter blade.....	21
Figure 5.5 Stopper spring and adjustment bolt.....	22
Figure 5.6 Adjusting the plastic film cutter blade (at rest)	22
Figure 6.1 Grease gun lubrication.....	23
Figure 6.2 Lubricating the plastic film stretcher	27
Figure 6.3 Lubricating the chain (through the hole in the guard)	27
Figure 6.4 Lubricating the plastic film cutter 1.....	28
Figure 6.5 Lubricating the plastic film cutter 2.....	28
Figure 7.1 Starter fuse.....	31
Figure 8.1 Hydraulic unit and work light	32
Figure 8.2 Stabilizers	33
Figure 8.3 Bale loading arm	34
Figure 8.4 Bale unloading platform D	34
Figure 8.5 Bale unloading platform D3.....	35
Figure 8.6 Accumulator of the unloading arm.....	39
Figure 8.7 Double roll unit	39

How to Reach Us

When you contact us, always provide us with the following information:

- Your name, address, and telephone number;
- Product model and serial number;
- Purchase date and invoice number;
- Dealer name, address, and telephone number and salesperson name;
- Precise and detailed description of your problem.

Address: **ANDERSON EQUIPMENT**
5125 de la Plaisance
Chesterville (Québec)
CANADA G0P 1J0

Email Service: service@anderson-equipment.com

Fax Service: 1-819-382-2218

Website: www.anderson-equipment.com

ANDERSON LIMITED WARRANTY

Warranty form must be completed and returned.

Please fill in this form with information about your new machine. **Please return this form to us in the 15 days following the date of delivery** to validate your warranty. Details of the warranty provided can be found in the operator's manual.

Warranty Validation

(to be mailed or faxed within 15 days)

Type of Machine:	
Model:	
Options:	
Serial Number:	
Date of Sale to Customer:	
Customer Name:	
Customer Address:	
Customer Telephone Number:	
Dealer Name:	
Salesperson Name:	
Dealer Address:	
Salesperson signature:	
Customer signature:	

FAX: 1-819-382-2218

For your personal records, we recommend that you fill in this form with information about your machine.

Type of Machine:	
Model:	
Options:	
Serial Number:	
Date of Sale to Customer:	
Customer Name:	
Customer Address:	
Customer Telephone Number:	
Dealer Name:	
Salesperson Name:	
Dealer Address:	
Salesperson Signature:	
Customer Signature:	

1 ANDERSON Limited Warranty

One-Year Limited Warranty

In the year following the purchase of a new machine, if your ANDERSON equipment fails to operate properly due to defective materials, manufacturing, or assembly, our company will furnish replacement parts and repair your machine free of charge.

Documents

Keep your original invoice or a photocopy. Please refer to your invoice or to the information on the preceding page whenever you order parts, for any questions about the operating procedures of your machine or for any questions you might have concerning your warranty.

Problem Resolution

Your satisfaction is a priority for your dealer and for us. Normally, all problems concerning our products are taken care of by the dealer's service department. Please follow the following steps if you are not satisfied after consulting your dealer:

- First, let it be understood that our warranty is void if your equipment has been modified without our express authorization. Let it also be understood that we alone will determine the cause of the problem or how the machine was broken. Please note that all repairs must be authorized before any work is performed to ensure that your machine remains covered by the warranty.
- If your problem has already been dealt with by your dealer's service department but you are not completely satisfied, please contact one of the managers of the dealership that sold you the Anderson machine. In most cases, your problem can be solved at this level.
- If your problem still has not been resolved to your satisfaction after this step, please contact us directly.

When you contact us, always provide us with the following information:

- Your name, address, and telephone number;
 - Product model and serial number;
 - Purchase date and invoice number;
 - Dealer name, address, and telephone number and salesperson name;
 - Precise and detailed description of your problem.
- 1.3.4 After reviewing all aspects of the problem, we will rapidly communicate our decision to you and, if applicable, the steps taken to resolve the situation. It is nonetheless likely that your problem will be solved by your dealer using his team and specialized equipment. We therefore strongly suggest that if you need any kind of help, your first contact should be made directly with your dealer.

Modifications

Given that our desire is to always improve our products, our company reserves the right to modify its machines, their characteristics, and their parts at any time without advance notice or obligation.

Thank you for placing your confidence in us

Dany Poisson, President
Anderson Equipment



**ANDERSON EQUIPMENT
LIMITED WARRANTY**

The **one-year warranty** period will begin on the date the new equipment is sold to the customer. However, if your equipment is used for **commercial or rental purposes**, this warranty will only be valid for a period of **90 days or a maximum of 3500 bales for in-line bale wrappers and 2500 bales for individual bale wrappers beginning on the date of purchase.**

1. During the year following the purchase of a new machine, if your ANDERSON equipment fails to function properly due to defective design, materials, manufacturing, or assembly, our company will repair your equipment free of charge.
2. Replacement or repair of equipment parts will be performed by the dealer or by our technician. This includes parts and labour **only if preauthorized by our customer service department.**
3. However, the customer will be responsible for transporting the equipment to/from the authorized dealer's head office.
4. The dealer will describe the terms of this warranty to the customer before the retail sale and will record the date of purchase, the serial number, and the equipment description. The dealer will fax the duly completed warranty form in the 15 days following the transaction to the following number: 1-819-382-2218 to validate the warranty.
5. To have equipment repaired under the warranty, the customer must advise his dealer **as soon as possible** of the problem and request that the repairs be made according to the terms of the applicable warranty.
6. For all repair requests made to an **Anderson** dealer, you must furnish **the date of sale, the serial number, the type of equipment and options, and the owner's contact information.**
7. **Anderson equipment reserves the rights to modify the warranty policy at any time without advance notice.**
8. Notwithstanding the foregoing.

Warranty Exemptions

1. **Certain parts**, such as the tires, the battery, and the Honda engine, **are covered under warranties from their respective manufacturers. Please contact the appropriate manufacturer.**
2. If the equipment has been subjected to bad treatment or negligence, has been used inappropriately, has not received necessary maintenance, has not been appropriately protected during storage, has been damaged by vandalism, bad weather, natural elements, collision, or accident.
3. Let it be understood that our warranty is void if your equipment has been modified without our express authorization.
4. This warranty **does not cover** normal maintenance services (such as adjustments, oil changes, normal wear and tear, etc.)
5. The customer will be responsible for service calls and/or transporting the equipment to/from the authorized dealer's head office. **The warranty does not cover towing expenses.**
6. If parts or accessories other than those **manufactured or sold by Anderson Equipment** have been used the authorization of the customer service department, and if we decide that their use negatively impacts the performance, stability, or reliability of the equipment.

Exclusive Remedy

To the extent permitted by law, the purchaser's exclusive remedy in connection with the breach or performance of any warranty on the equipment are those set forth in this warranty.

In no event will Anderson Equipment be liable for any incidental or consequential damages or injuries, including but not limited to loss of profits, rental of substitute equipment, or other commercial or personal loss or damages arising as a result of a fundamental breach or breach of a fundamental term.

No Dealer Warranty

Except for conditions or warranties which may not be excluded by law, the selling dealer makes no warranty of its own on any item warranted by **Anderson Equipment** unless it delivers to the purchaser a separate written warranty document specifically warranting the item. **The selling dealer has no authority to make any representation or promise on behalf of Anderson Equipment or to modify the terms or limitations of this warranty in any way.**

Right of Modification

Given that our desire is to always improve our products, our company reserves the right to modify its machines, their characteristics, and their parts at any time **without advance notice or obligation.**

ANDERSON EQUIPMENT

5125 de la Plaisance
Chesterville (Québec)
CANADA GOP 1J0
Email Service: service@anderson-equipment.com
Fax Service: (819) 382-2218

2 Safety

Your ANDERSON bale wrapper was designed to reduce to a minimum the risks to the operator. However, it must be used only for the work it was designed for. Additionally, since it includes a powerful hydraulic system, moving metal parts, and a gasoline engine (optional) and all these elements can cause serious injury to humans or animals, it is strongly recommended to read and to closely adhere to the following guidelines.

Safe Operators

Be familiar with operating procedures before using your ANDERSON bale wrapper. Also insist that these directions be followed by all who use your bale wrapper. Make sure that your operators know the emergency telephone numbers and the location of your first aid kit. Only allow the bale wrapper to be used by responsible people who have been fully trained in its safe operation.

Danger Zone

Do not allow yourself to be disturbed during the installation or the operation of the machine. As an operator, you must be the only person to move about the machine within a security zone of 5 metres (16 feet) diameter. Keep all other people, especially children, away from the site, as well as domestic animals.

Secure Attachment to the Tractor

The machine must be properly attached to the fixed drawbar of the tractor so that the bale wrapper is positioned as high as possible. To increase the stability of the bale wrapper, choose a flat and level ground and use the stabilizers, if you have that option.

Dangerous Situations

Pay attention to the stickers and the warning labels that appear on your machine. Know how to make an emergency stop. Before starting the engine, make sure that all controls are in neutral position. It is always dangerous to stand on the machine. Keep fingers, hands, and feet away from moving parts: chains, gears, etc. Recall that all parts are potentially dangerous because certain parts can be activated suddenly. Be especially cautious around the plastic film cutter, which contains sharp parts under tension.

Prevention

The clothes that you wear as an operator must be safe. Avoid wide sleeves and pants, scarves, and shirt or coat sleeves that could become stuck in the moving parts of the machine. Additionally, wear adequate hearing protection to reduce the danger of hearing loss due to continued exposure to the noise of the bale wrapper. Also use an approved mask in dusty conditions. If you work in the evening or at night, make sure that you have sufficient lighting to work safely. Have a working fire extinguisher within arm's reach. Keep the protective shields and other security devices in place and never use your bale wrapper if they have been removed or damaged.

Safe Maintenance and Repair

Stop the engine and remove the switch key (from the tractor and/or from the hydraulic unit) before performing maintenance, adjustments, or repairs. Release the oil pressure before moving beneath certain hydraulically lifted parts and be aware of the blade of the plastic film cutter. Replace all defective or worn out parts. We recommend you use original or approved parts in order to protect your warranty and to obtain optimal performance from your machine.

Fuel

Gasoline is a very flammable substance which must be handled with care in an approved container when you fill the engine tank of your hydraulic unit. Put back in place and firmly tighten the tank cap and wipe away any spilled fuel. Never add gasoline when the engine is hot or operating. Have a working fire extinguisher within arm's reach near the baling site.

Hydraulic Oil

Any leak of pressurized oil can cause serious injuries. Do not use your hands to locate a leak, but rather an object such as a piece of cardboard. Stop the engine and release the pressure before disconnecting or reconnecting the lines. Firmly tighten all connections before restarting the engine or reapplying hydraulic pressure.



WARNING !

Any hydraulic fluid that makes contact on or underneath the skin must be removed within hours by a doctor familiar with this type of injury. Without intervention, very serious problems may result.

Travelling Safely on Public Roads

If you travel on public roads, you are responsible for respecting the identification and lighting regulations of your region. We recommend that you always attach a security chain to the hitch point between the machine and your tractor and that you lock the coupling link with a pin.

Attach the turntable's (Figure 2.1) L-shaped lock (1). Rotate the table as needed so that the latch faces the notch (2) at the front of the frame. Remove the latch pin. Slide the latch toward the notch and insert the latch shaft. Place the pin in the hole of the notch.

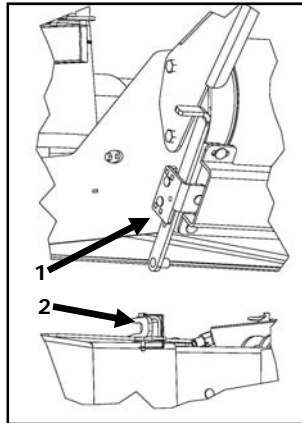

Figure 2.1 Lock of the turntable

End of Operation

If you will not use the bale wrapper again for a long period of time, do not forget to close the engine fuel valve (1), located beneath the choke on the right side of the engine (Figure 2.2).

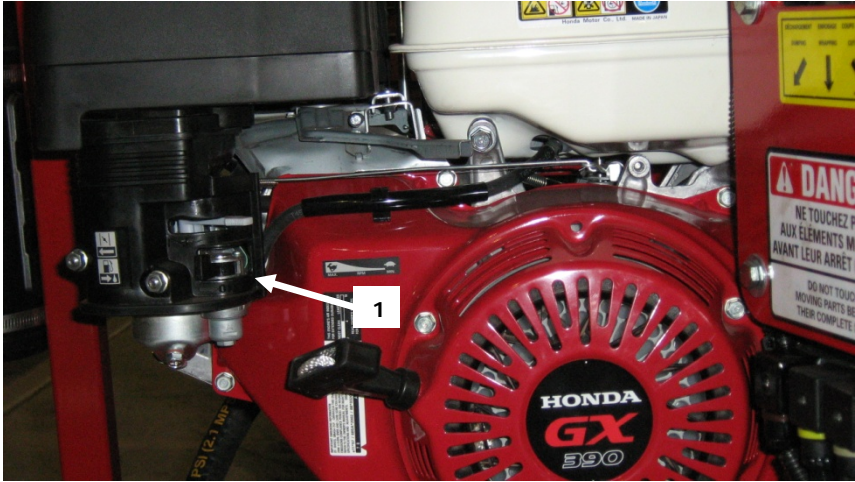

Figure 2.2 Closing the fuel valve

3 General Characteristics and Specifications

Congratulations! You are now the owner of an ANDERSON bale wrapper, a high-quality machine designed for the separate storage of round bales of up to 5 feet (1.5m) in diameter. This agricultural machine is carefully manufactured by our company to give you many years of reliable performance.

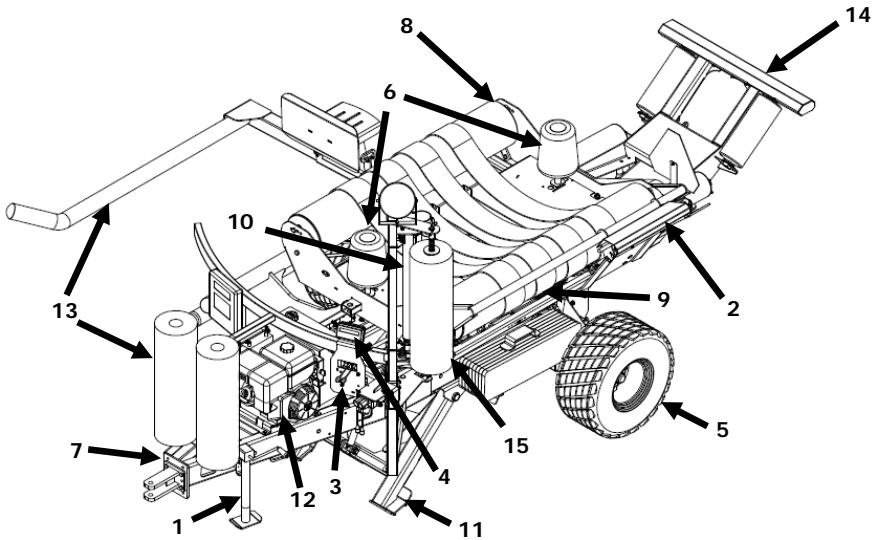

Figure 3.1 Components of the wrapper

Components	#
Jack with side crank	1
Mechanical film cutter	2
Manual controls	3
Bale and revolution counter	4
26 x 12 x 12 Tires (8 plies)	5
Support roller	6
Tongue	7
Turntable	8
Tilting table	9
Plastic film stretcher	10
Optional Components	
Stabilizers	11
Hydraulic unit with 13HP Honda motor and electric starter, alternator, and work lights	12
Loading arm and plastic film roll support	13
Unloading platform (D) (regular)	14
Unloading platform (D3) (3 positions)	---
Double film roll unit	15

* It is not possible to combine the loading arm and stabilizer options

General Specifications

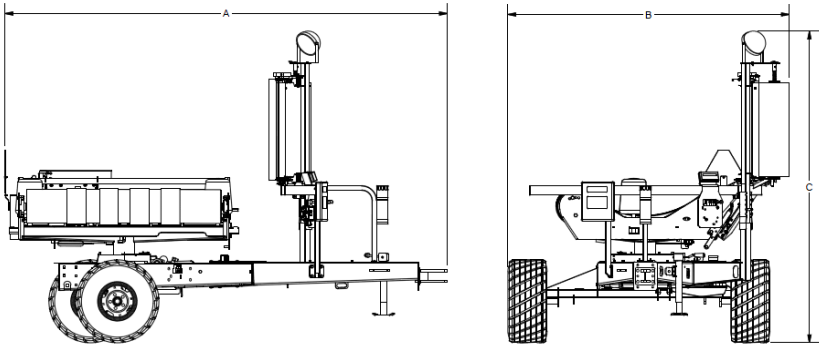

Figure 3.2 Exterior dimensions for the base model

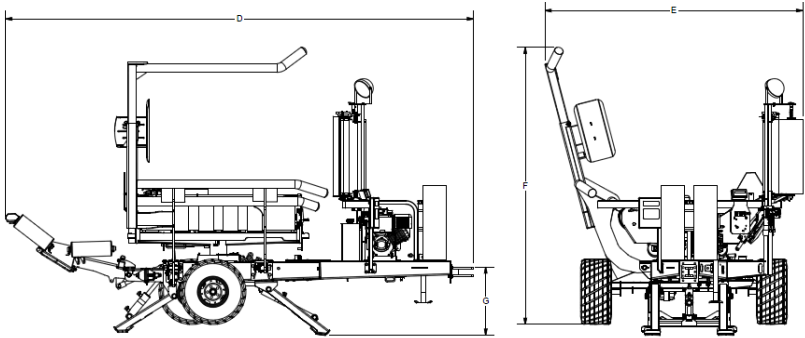

Figure 3.3 Exterior dimensions for model with optional

Dimensions and Weight for base model		Dimensions and Weight for model with optional	
Length (A)	140 po (3,55m)	Length (D)	187,50 po (4,77m)
Width (B)	89 po (2,26m)	Width (E)	100,75 po (2,56m)
Height (C)	99 po (2,51m)	Height (F)	118,50 po (3,01m)
Total weight*	1896 lbs (860 kg)	Weight of stabilizers	250 lbs (113 kg)
* Without hydraulic unit or optional components.		Weight of hydraulic unit	386 lbs (175 kg)
		Weight of loading arm	Arm: 465 lbs (210 kg) Weight: 550 lbs (249 kg)
		Poids support de rouleaux plastiques	20 lbs (9 kg)
		Weight of unloading platform D	420 lbs (190 kg)
		Weight of unloading platform D3	550 lbs (250 kg)
		Weight of double film roll unit	55 lbs (25 kg)

4 Adjustment Procedures

Verifications Before Each Use

Check the hydraulic oil level in the tank of your unit if your bale wrapper is equipped with this option. Check the oil level in the Honda engine, if applicable, as well as the need for fuel. Open the fuel valve and check the engine air filter. If necessary, lubricate the machine well after each day of use. Every day, check the cleanliness of the plastic film stretcher rollers. Clean them as necessary with penetrating oil, rubbing alcohol, or paint thinner.

At start-up, your bale wrapper must be placed in the most horizontal position possible. Detach the turntable's L-shaped latch (Figure 2.1). If you have the stabilizer option, start the machine and pull the 2 levers of the control to put them in place (Figure 5.2). If the film roll is in place, check if the edge of the plastic is properly held by the clamp of the film cutter. If not, you can attach the plastic directly onto the bale ties.

Installing the Plastic Film Roll

When the film roll is empty, remove the spool by pushing it upward to compress the retaining spring of the upper support (Figure 4.1). Install the new roll in the same manner.

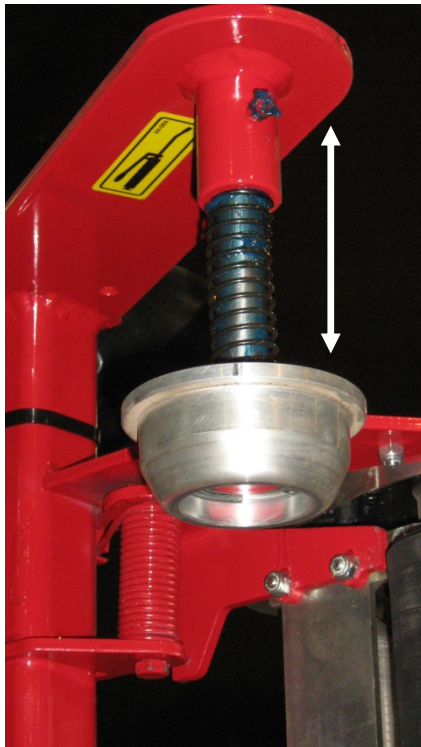

Figure 4.1 Installing the film roll

Follow the diagram (Figure 4.2) to unroll the start of the film between the rubber roller and an aluminium roller, then around the other aluminium roller. The edge of the plastic must be attached onto the ties or the net of the first bale.

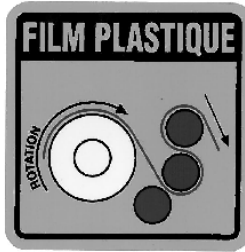

Figure 4.2 Direction of film unwinding



WARNING !

Avoid leaving the plastic film rolls in the sun for a long period of time before using them. Prolonged sun exposure can cause the film to break or deteriorate during wrapping.

Testing the Plastic Film Stretcher

To check the effectiveness of your system, draw a 10-inch (25 cm) horizontal line on your plastic film roll with a felt-tip pen. Turn the table about one revolution and stop. Once the line has passed the aluminum rollers, measure it on the bale. If it has stretched up to a length of approximately 16.5 inches (41 cm), this means that your film stretcher is working properly. If the film does not stretch properly, check the gears of the film stretcher, and if the plastic film roll and the free roller turn freely, clean the aluminum rollers.

Adjusting the Two Support Rollers

These two conically shaped support rollers are made of rigid plastic and are placed on each end of the table between the feed rollers to hold your bale in place. In the factory, they are placed 48 inches (1.2 m) apart to hold bales of 48 inches (1.2 m) in width. Move them together or apart as necessary according to the average width of your bales by removing the pins beneath the table and changing their position. The support rollers can hold bales up to 60 inches (1.5 m) in width (Figure 4.3).

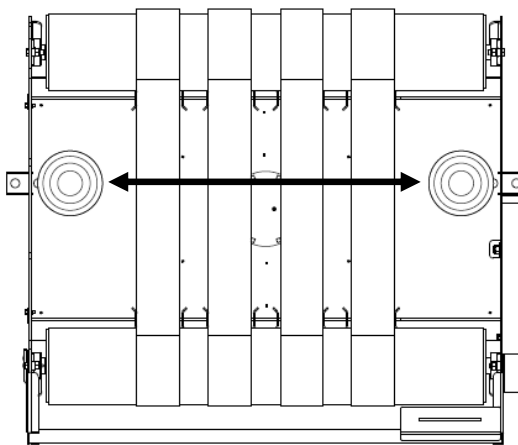

Figure 4.3 Adjusting the support rollers

5 Operating Procedures

5.1 Moving the Bale Wrapper

Short and Medium Distances

Your machine can be moved short and medium distances behind a tractor. Fasten the turntable latch (Figure 2.1). Attach the machine and attach a security chain to the ring provided for this purpose on the draw bar. On public roads, follow the traffic regulations of your region for agricultural machines, including those concerning the use of agricultural machines by minors.

Safety Measures



WARNING !

Regardless of method, during transportation, do not stand on and do not let anyone else stand on the machine.



WARNING !

Close the fuel valve if it is necessary, because the gasoline could leak into the engine base.

5.2 Using the IG-C3 Bale Counter

Characteristics

The IG-C3 bale counter is powered by a rechargeable battery. Use the provided AC/DC charger as needed. The module consists of a 2-line screen with 4 buttons beneath it. Start up the counter by touching the **ON/OFF** button on the left. This opens the first **Anderson** window. Five seconds later, the screen will look as follows:

- In the upper left corner of this window, **rev: 00** will count each wrapping as you operate the bale wrapper.
- On the second line of the window, **Bales (D): 000** shows the total bales wrapped in the day.
- In the upper right corner, **MAX: 18** shows the maximum number of revolutions programmed for each bale. When your number of revolutions approaches this number, the screen will begin to blink. You will hear three warning beeps, but the machine will not stop automatically. Bales/total will increase by 1, and after 15 seconds, the number of revolutions will return to 0.

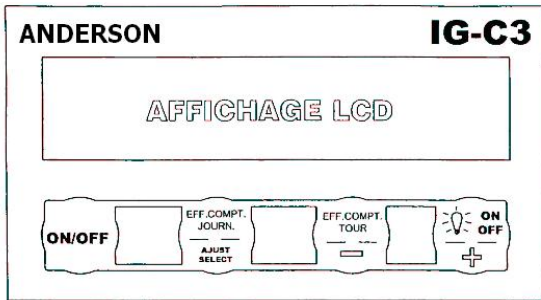

Figure 5.1 Bale counter screen

Operation Menu of the IG-C3 Bale Counter

- If you press the **ER. COUNT. DAY.** button, the screen will ask you to confirm NO **-** or YES **+** whether you really want to erase the daily counter.
- Similarly, the **ER. COUNT. REV.** button allows you to reset the revolution counter to zero during a test or during a missed cycle. You must confirm the operation.
- The **ON / OFF** button on the right allows you to turn on or off the illumination of the screen during operation. The internal battery consumes 10 times less energy when the screen is turned off. The illumination of the screen automatically turns off after 20 seconds if the counter is not being used.
- To shut down the module and close the operation MENU, press the **ON/OFF** button on the left. The data will be saved. When not being used, the bale counter will go into energy saver mode after 5 minutes.

Advanced Menu of the IG-C3 Bale Counter

To reach this menu, hold down the **ADJUST.SELECT** button for 3 seconds.

- Program 1: The 1st program allows you to: **Enter the number of revolutions, MAX: 00** per bale by pushing the **- / +** buttons. The minimum number is 2 and the maximum is 80. Holding down one of the **- / +** buttons for 3 seconds will cause the number to change faster. We recommend 18 revolutions with 30-inch plastic rolls so as to obtain 4 layers on all surfaces of the bale. Certain users will want more layers or fewer layers.
- Program 2: Pushing the **ADJUST. SELECT** button again will take you to program 2, which allows you to **modify # bales Day: 000** (in the same manner as for program 1). If you press the **- / +** buttons simultaneously, the number will be reset to zero.
- Program 3: Pushing the **ADJUST.SELECT** button a third time will take you to program 3, which allows you to: **modify # bales Year: 0000**.
- Program 4: Choose your language with the **- / +** buttons: French or English.

You have finished programming the bale counter and the **ADJUST.SELECT** menu will bring you back to the operation menu.

5.3 Start and End Wrapping

Start-Up



If you do not use the optional hydraulic unit, adjust your tractor at a flow rate of 8 GPM at 2000 PSI.

WARNING !

Make sure your bale counter has been properly programmed.

Levers

Once the table's latch has been removed, use the levers to lower the rear (1) and front (2) stabilizers (Figure 5.2) if applicable. Depending on the hardness of the ground, it is possible that after a dozen bales you will have to manually readjust the stabilizers to solidify your machine or keep it properly horizontal.

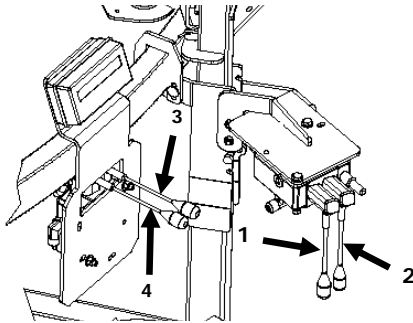

Figure 5.2 580 Levers

#	FONCTION
1	Rear stabilizer
2	Front stabilizer
3	Wrapping lever
4	Tilt the table

Note: With the Hydraulic Unit and Stabilizers options, only one tractor is needed to continuously wrap bales.

First Bale

Take a round bale and place it in the center of the feed rollers, preferably on the side opposite the plastic film stretcher. The bale will turn counterclockwise. Attach the edge of the plastic film to the ties or net of the bale. Pull the wrapping lever (3). Wrapping will begin. When you approach the maximum number of rotations, the screen of the counter will blink and you will hear 3 beeps. Stop wrapping when the table is properly aligned (the axis of the bale must be parallel to the axis of the axle).

Unloading and Second Bale

Take the time to properly align your table well so that the bale falls backward from the wrapper and the plastic film cutter system forward, then pull its lever (4) to tilt the table. During this operation, the plastic film cutter will be engaged and will cut the plastic film and hold onto one of the cut ends. Next, lower the table again and place a new bale on the feed rollers. The first bale can be retrieved from the ground.



Warning !

Tilt the table when it is badly aligned may cause damage to your machine.

End Bale Wrapping

If you have the hydraulic unit, shut off the fuel valve to prevent the gasoline from seeping into the engine oil. Once your batch of bales has been stored, take the time to check the air tightness of the plastic film on your bales. As necessary, seal the air leaks with tape so that fermentation will begin rapidly. Use the tape recommended by your plastic film supplier.

5.4 Bale Wrapping: Adjusting the Sensors

Adjusting the Rotation Counter Sensor

Place the 2 parts of the sensor at position 1 so that they face each other, turning the table by pulling the control valve lever, and adjust the distance between them to 1/8 inch (2.5 mm)(Figure 5.3)

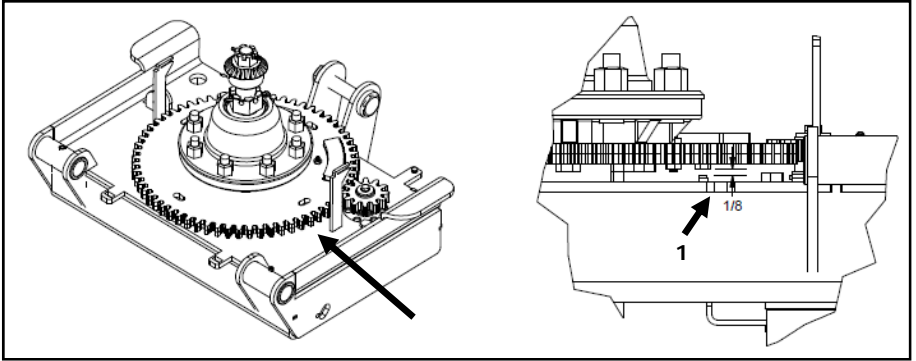

Figure 5.3 Rotation counter sensor

5.5 Adjusting the Mechanical Plastic Film Cutter

-First, check the condition of the steel blade (1) and replace it as needed (Figure 5.4).

-Increase the force of the stopper spring as needed. Move the bolt (2) holding the spring in a hole, thereby making it possible to further compress the spring (Figure 5.5) for a better hold on the plastic.

-Reposition the blade (3) (Figure 5.6) to change when the plastic film cutter closes during bale unloading. Ideally the plastic film cutter is actuated just before the table is fully lifted.

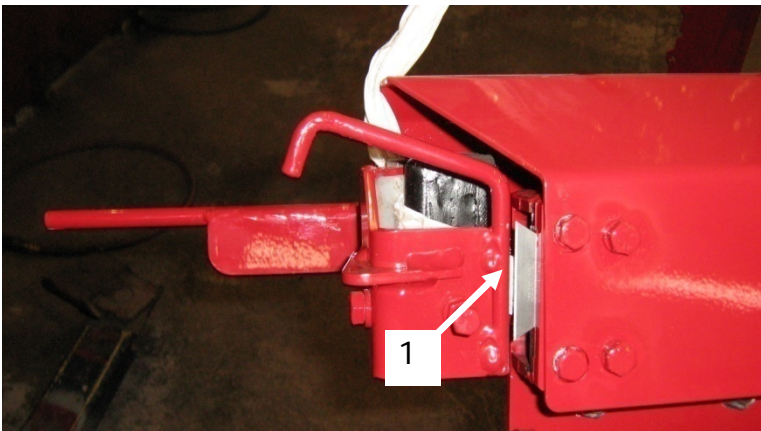

Figure 5.4 Plastic film cutter blade

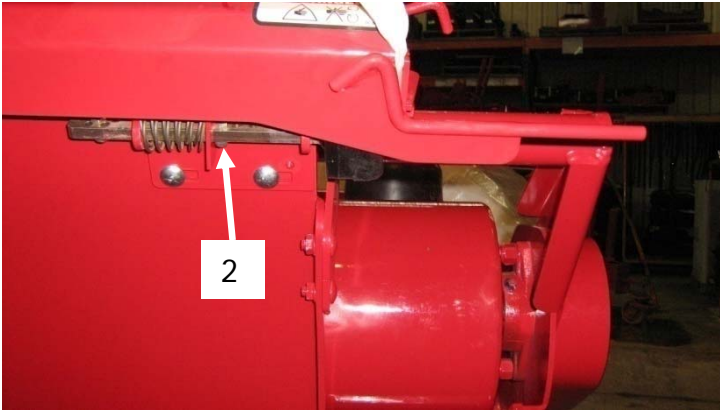

Figure 5.5 Stopper spring and adjustment bolt

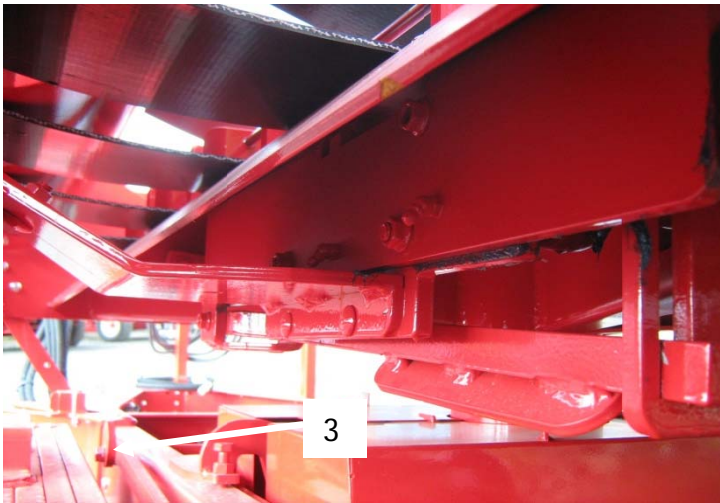

Figure 5.6 Adjusting the plastic film cutter blade (at rest)

6 Maintenance Procedures

Maintenance



Warning !

Before performing any maintenance operations on your machine, ensure that you are following the security precautions laid out in the safe maintenance and repair section: stop the engine (of the tractor or the unit), turn off the receiver, release hydraulic pressure, etc.

Grease Gun Lubrication

Your ANDERSON bale wrapper must be lubricated with a grease gun in the places indicated by the sticker (Figure 6.1).

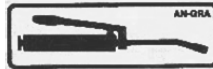

Figure 6.1 Grease gun lubrication



Note: The use of synthetic grease is highly recommended

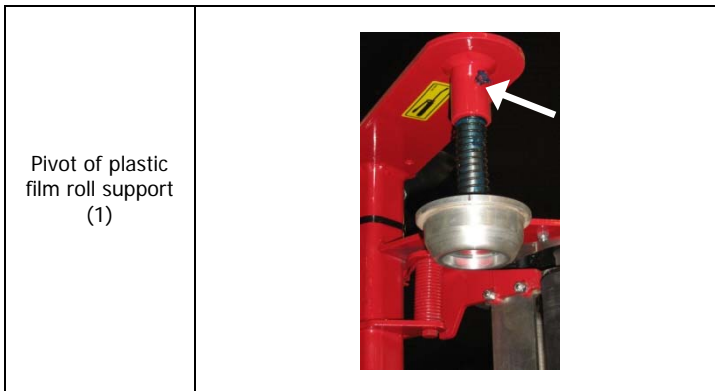

Greasing Frequency

Frequency	Greasing (number of grease cups)
Every 200 bales	Pivot of plastic film roll support (1) Central axle of turntable (1 on the top) Pivots of tilting table (2) Axles of the tilting cylinder (2) Axles of the unloading platform cylinder (2)* Pivot of the unloading arm (2)* Axles of the unloading arm cylinder (2)* Pivot of the unloading platform (4)*
Every 500 bales	Front and rear stabilizers (4)*
Every 1000 bales	Bearings of the two feed rollers of the belts (1 on each end, total of 4)

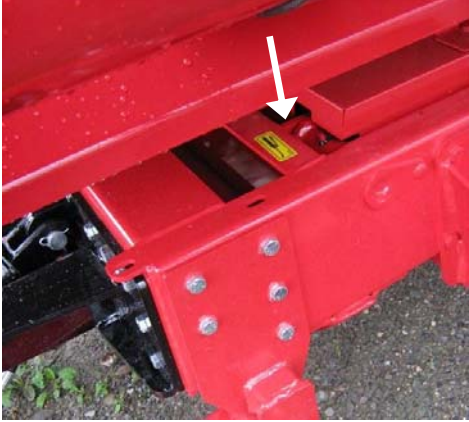
* Optional equipment



<p>Central axle of turntable (1 on the top)</p>	
<p>Pivots of tilting table (2)*</p>	
<p>Axles of the tilting cylinder (2)</p>	

<p>Axles of the unloading platform cylinder (2)*</p>	
<p>Pivot of the unloading arm (2)*</p>	
<p>Axles of the unloading arm cylinder (2)*</p>	

Pivot of the unloading platform (4)*



Front and rear stabilizers (2 grease cups each) and cylinder axles (2each)*

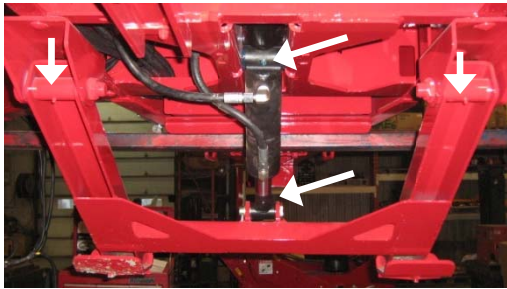

Bearings of the two feed rollers of the belts (1 on each end, total of 4)



Other Lubrication Points

The power transmission chains and other moving parts of the machine must be oiled or greased regularly or every 50 hours. This also applies to the 2 toothed wheels of the plastic film stretcher.



Figure 6.2 Lubricating the plastic film stretcher



Figure 6.3 Lubricating the chain (through the hole in the guard)

The film cutter must be lubricated daily (approximately 100 balls) where indicated in the following figures:



Use a antifriction lubricant to lubricate the film cutter system.

Do not use grease because it causes the accumulation of dust that affect the lubricating.



Figure 6.4 Lubricating the plastic film cutter 1

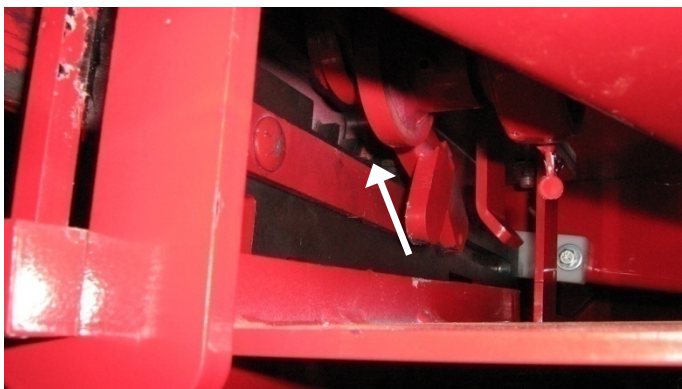

Figure 6.5 Lubricating the plastic film cutter 2

The film cutter must be lubricated daily (approximately 100 balls) where indicated in the following figures:



IMPORTANT !

Use a antifriction lubricant to lubricate the film cutter system.

Do not use grease.

Cleaning and Other Maintenance

Pay particular attention to the cleanliness of the plastic film cutter system. An accumulation of debris (hay, dust, string, etc.) can reduce its functionality. Regularly check the cutting condition of the blade.

Always keep the rollers and the gears of the plastic film stretcher free of all residues to prevent these parts from jamming, breaking, or tearing the plastic film. As necessary, wash the aluminum rollers with rubbing alcohol, penetrating oil, or paint thinner.

Also remove the hay that can get stuck in the axles and gears of the machine to not place needless strain on the hydraulic motor.

For the maintenance of the hydraulic unit, we recommend that you follow the Honda instruction manual for the maintenance of your engine. Check the oil level of the HONDA engine on each day of operation. The engine air filter must be checked each time you begin wrapping and cleaned as needed. As for changing the hydraulic oil, filter, and strainer, we recommend that you perform this maintenance every 5000 wrapped bales. It is a good idea to free the area around the gasoline engine of all flammable material.

Storage

To unhitch the machine, follow these steps:



Warning !

During unhitching operations, the operator is the only person authorized to be near the machine.

Before lowering the tractor to remove the hydraulic connections, and the electric cables, the operator must ensure that the machine is fully on the ground and stable. S/he must also engage the hand brake, turn off the tractor, and remove the key from the ignition switch.

- Secure the machine in a stable location.
- Use chocks to prevent the machine from moving while being unhitched from the tractor.
- Disconnect the hydraulic connections from the tractor.
- Disconnect the power cables.
- Remove the fixing pin and the security chain to rotate the jack.
- Replace the fixing pin and the security chain.
- Lift the pole with the jack.
- Remove the fixing pin and the security chain.



Warning !

Ensure that you have released the hydraulic pressure from the tractor's system to make disconnection and future reconnection easier.

- Remove the bale counter and store in a dry place.

It is preferable to keep the machine in a dry, covered place so that it will be in good condition when it is used again.

7 Troubleshooting: Problems and Solutions

Before calling a technician, examine your machine and consult the table below to find a solution. If you are still not able to solve the problem yourself, ask for help from the customer service department of your agricultural dealer.

Troubleshooting Table

Problems	Possible Causes	Solutions
1. The IG-C3 counter does not turn on.	Lack of power.	Install the provided AC/DC charger or the charge wire on the module.
2. The IG-C3 turns on but does not count revolutions.	Defective sensor or problem with wiring or connections.	Check the wiring and connections, replace the sensor if necessary.
3. The engine of the hydraulic unit does not start.	The fuel valve is closed.	Open the fuel valve and start again.
	The gas tank is empty.	Put fuel in the tank and start again.
	The low engine oil sensor is activated.	Add oil to the engine and start again.
	The spark plug is clogged or defective	Clean the spark plug or change it.
	The engine is flooded because the fuel valve was not closed the previous day or during transportation.	Remove the spark plug, dry it out, dry out the cylinder by activating the starter crank. Put back the spark plug and start again.
	The fuse in the HONDA switch key box is burned out	Replace the fuse (Figure 7.1)
4. The turntable does not turn or turns slowly.	The level of hydraulic oil or the flow rate of the hydraulic unit or the tractor is too low	Check for oil leaks and breaks. Retighten or repair as necessary. Add hydraulic oil to the tank. Check the tractor's flow rate (8 GPM).
	The HONDA motor turns too slowly.	The motor must be adjusted to 3600 revolutions/min.
5. The plastic film wrapping is unsatisfactory.	The plastic film breaks, develops holes, or tears during wrapping.	Check if the roll installed was damaged to begin with and replace it if necessary.
		Check if hay or something else is inhibiting or blocking the plastic film stretcher. Remove the object and clean the film stretcher. Check if all the rollers are turning freely.
		The film is too soft because it has been in the sun for too long before being used. Install a cooler roll.
	The plastic film is not tight enough on the bale.	Check if the plastic film roll is properly installed. Check if the parts of the plastic film stretcher are in good condition and turn freely. Repair as needed.
6. The plastic film cutter does not work well.	The plastic film cutter clamp does not hold onto the end of the plastic film.	The rubber stopper moves back too far on its adjustment bolt. Adjust the bolt. The stopper spring needs to be more tense (Figure 5.5).

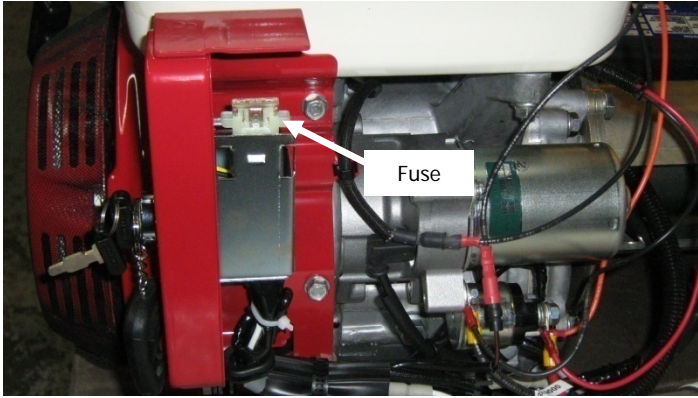

Figure 7.1 Starter fuse

8 Optional Equipment

Hydraulic Unit

The 580 bale wrapper can function with your tractor's hydraulic system or with an optional independent hydraulic unit which includes:

- A 13 horsepower Honda gasoline engine;
- A pump adapter and a hydraulic pump;
- A hydraulic oil tank with oil filter and strainer.

We recommend that you follow the Honda instruction manual for the proper maintenance of your engine.



IMPORTANT !

The engine air filter must be checked at the start of each wrapping session and cleaned as needed

We recommend that you change the hydraulic oil, the filter, and the strainer every 5000 wrapped bales.

Electric starter with 18 amp. alternator and work light

These 2 options complement the Honda engine of the hydraulic unit. The work light (1) is installed on top of the plastic film stretcher (Figure 8.1).

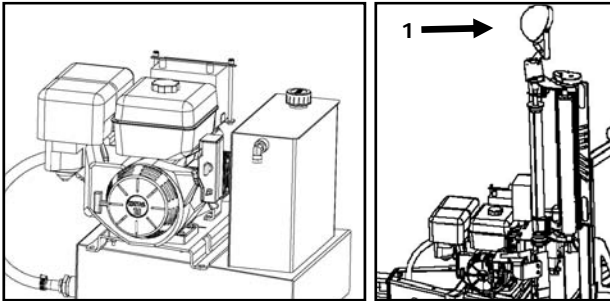

Figure 8.1 Hydraulic unit and work light

Stabilizers

Activated by hydraulic cylinders and controlled by manual controls at the front of the machine, these two pieces of equipment improve the stability of the bale wrapper. They are equipped with security valves (lock valves) to prevent inadvertent movement of stabilizers or the feet from collapsing, whether the machine is turned on or not. The stabilizer option and the hydraulic unit option make it possible to completely detach the bale wrapper and to function independently, one tractor is required to handle bales.

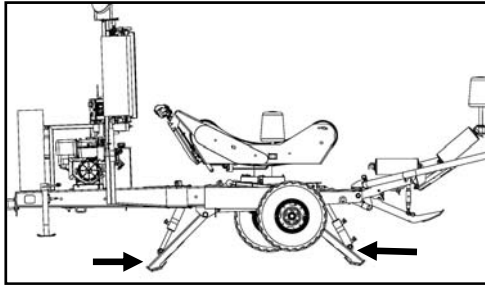

Figure 8.2 Stabilizers

Modifying Gears to Reduce Stretch Ratio

It is possible to modify the standard stretch ratio (65%) by changing the gears of the plastic film stretcher and thereby obtain a ratio of approximately 55%. Contact your dealer to obtain this accessory.

Bale Loading Arm and Plastic Film Roll Support

As an option, a loading arm can be installed on the bale wrapper **only at Anderson manufacture**. This arm makes it possible to load bales directly onto the bale wrapper without using a frontal loader.

1. The loading arm option is always sent with extension cables to control the wrapper from the tractor seat and a rack to carry two extra rolls of plastic.
2. For loading the bale, the turntable must be parallel to the loading arm.
3. The loading arm is equipped with a safety device to prevent collisions with the turntable and error operations. The loading arm must be dropped halfway between the turntable and the ground so that the table can rotate and wrap.
4. Adjustment of the loading arm :
Fork outer arm adjusts to different bale diameter. An adjustable backstop allows you to charge balls of 4 or 5 feet (1.2 m or 1.5m) wide and filed on the center of the turntable.
5. Transport



WARNING !

To transport the wrapper equipped with a loading arm, install the safety pin (1) that keeps the loading arm upright.

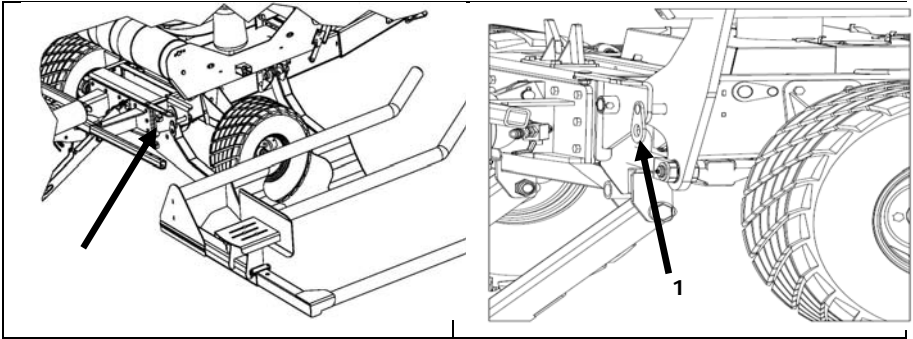

Figure 8.3 Bale loading arm

Bale Unloading Platform (D)

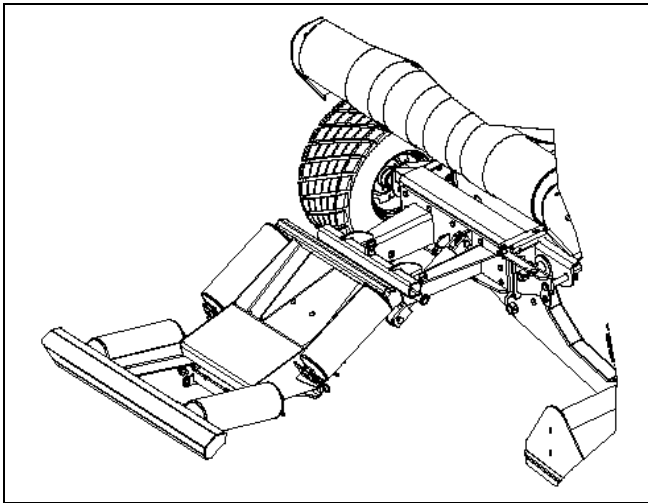

Figure 8.4 Bale unloading platform D

This unloading ramp makes it possible to gently discharge wrapped bales behind the bale wrapper. This system is composed of a rigid platform, a hydraulic cylinder, and a maintenance-free nitrogen cylinder.

Unloading Platform (D3)

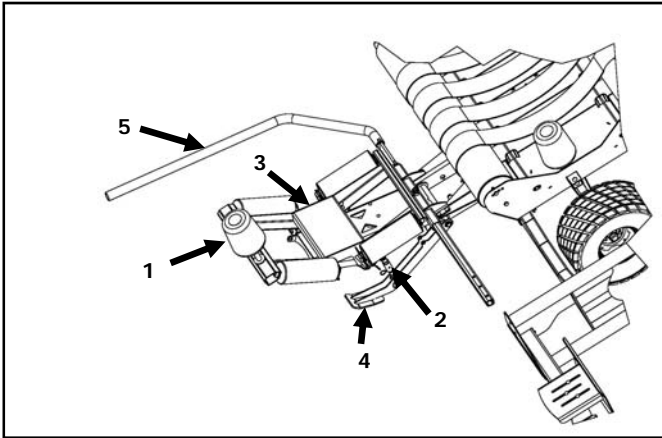

Figure 8.5 Bale unloading platform D3

This optional equipment makes it possible to bring the bales to a vertical position and set them down on the flat side.

Additionally, this unloading platform makes it possible to turn bales on one side or the other according to the preference of the user. To make this change, the operator need only place the barrier (6) on top of the platform, the foot (4), the support roller (1), and the retaining bar (5) on the other side of the unloading platform. The same attachment points are situated on each side of the platform to facilitate the change.



WARNING !



For transport, it is necessary to manually retract the retaining bar (2) (Figure 8.5).

With the D3 option, it is possible to gently discharge bales on the cylindrical side (without rotation). The operator need only raise the foot, remove the support roller (1), and ensure that the 2 platform barriers are installed to limit movement.

Installation of the three position unloading platform (D3)

Here are the steps to install the unloading platform D3 from the unloading platform D :

Installation of the foot

<p>Sand the shaft.</p>	 A close-up photograph showing a person's hands using a sanding block to smooth a metal shaft. The shaft is part of a larger mechanical assembly, and the person is wearing a grey long-sleeved shirt. The background shows a red-painted metal surface and a yellow and green logo.
<p>Slide the foot on the shaft and lock in place with the linchpin. (1).</p>	 A close-up photograph showing a hand sliding a metal foot onto a shaft. A white arrow points to the foot, and the number '1' is visible next to it. The shaft is part of a larger mechanical assembly, and the hand is wearing a grey long-sleeved shirt.

Attaching the retaining arm on the support

<p>Install the support of the arm.</p>	 A photograph of a black metal retaining arm with two mounting brackets. The arm is lying on a grey, textured surface. The mounting brackets are positioned at the ends of the arm, and there are two screws visible on each bracket.
--	--

Place the support on the dumping unit and bolt into place. Holes on the dumper are predrilled from the factory.



Installation of the retaining arm

Insert the fixed part of the arm into the support.



You can now attach the "L" shaped bar to the straight bar. (4 bolts)



Installation of the cone shaped roller

Remove the deflector at the end of the dumper to reveal the placement holes for the cone shaped roller.



Place the cone shaped roller on the same side as the foot as you will be bumping the bale to the opposite side.



This procedure is for if you are dropping the bale to the left side. The same procedure is used when dumping to the right side but the foot and cone roller will be placed on the other side of the machine. Also the "L" shaped retaining arm must be inserted opposite to the procedure.

Charging the accumulator

When the unloading platform does not go back to its position, you must correct the pressure in the accumulator to a pressure ranging from 1000 to 1200 lbs. A too low pressure will not lift the unloading platform to its position and a too high pressure will not allow the bale to dump from the unloading platform.

1. Remove the handle (1)
2. Turn the lock washer (2) to enable the handle to turn and open the ball valve (4).
3. Replace the handle (1).
4. Connect a hydraulic pump at the male quick connect (3).
5. Open the ball valve (4). The unloading platform will go down.
6. Put hydraulic oil to achieve a pressure of 1000 lbs. Press on the unloading platform for to verify if he goes back to its position and adjust the pressure as required.

7. Close the ball valve (4).
8. Remove the handle (1).
9. Turn the lock washer (2) that its lock the handle.
10. Replace the handle (1).

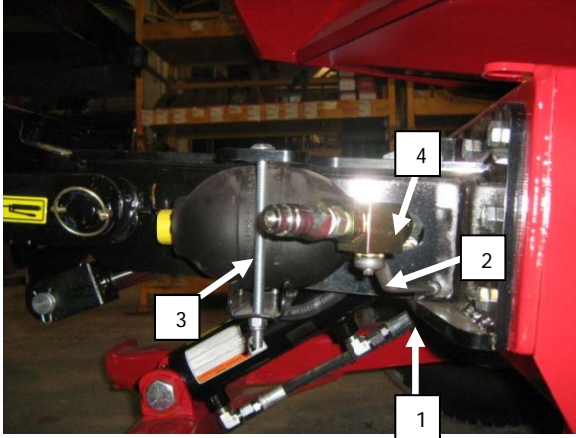

Figure 8.6 Accumulator of the unloading arm

If using a tractor for this procedure we recommend that you put a relief valve between the wrapper and the tractor. This way you can fully open the oil from the tractor and regulate it with the relief valve.

Double Roll Plastic Unit

The double roll option allows to install two plastic film rolls on the plastic film roll stretcher, thereby making it possible to apply a double layer of plastic with each rotation of the table. With this option, wrapping time will be decrease by almost half, because two layers of plastic are applied simultaneously.



Figure 8.7 Double roll unit

9 Start-Up Procedures

When you receive your new ANDERSON equipment:

Stationary mode:

1. Attach the bale wrapper to the tractor or stabilize the machine with the stabilizers and start the engine HONDA.
2. Remove the table lock on the bale wrapper (Figure 2.1).
3. Install a plastic film roll (Figure 4.1).
4. Enable the tractor hydraulic system or start the Honda engine.
5. Place a bale on the table, centered between the support rollers.
6. Attach the edge of the plastic film to the ties of the bale.
7. Pull the lever to begin wrapping (Figure 5.2).
8. Adjust the revolution of the engine to the wrapping speed desired.

Field mode:

1. Remove the table barrier on the bale wrapper (Figure 2.1).
2. Install a plastic film roll (Figure 4.1).
3. Enable the tractor hydraulic system or start the HONDA engine.
4. Place a bale on the table with the loading arm.
5. Only for the first bale, attach the end of the plastic wrap on the rope or bale net.
6. Pull the lever to begin wrapping (Figure 5.2).
7. Adjust the revolution of the engine to the wrapping speed desired.



Parts manual

ROUND BALE WRAPPER RB580

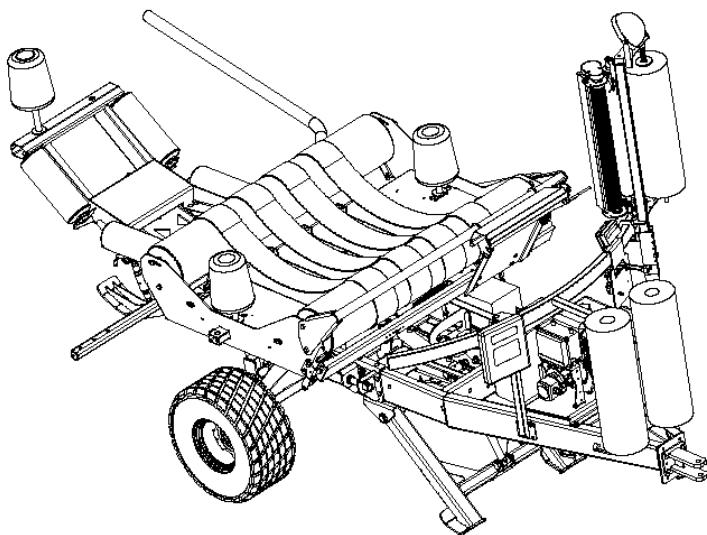

ALWAYS KEEP THIS MANUAL WITH THE WRAPPER

Content

1 – Main Frame	P. 2
2 – Plastic Roller Frame, Coupling Hand and Tongue	P. 3
3 – Axle	P. 4
4 – Stretcher Support Arm	P. 5
5 – Stretcher Support	P. 6
6 – Stretcher	P. 7
7 – Dumping Table	P. 8-10
8 – Shield	P. 11
9 – Rotary Table and Cut and Hold	P. 12-16
10 – Power Unit (option)	P. 17
11 – Loading Arm	P. 18-21
12 – Drop Off (option)	P. 22-24
13 – Stabilizer (option)	P. 25
14 – Hydraulic Diagram	P. 26-32

For any parts order, please use the parts manual to find the item(s) you need and contact your dealer to order it or contact us directly at :

ANDERSON GROUP

5125 de la Plaisance
Chesterville (Québec)
CANADA G0P 1J0

Fax : (819) 382-2643
Email : service@grpanderson.com

Visit our website → www.grpanderson.com

1 - MAIN FRAME

PARTS LIST				PARTS LIST			
ITEM	QTY	PART	DESCRIPTION	ITEM	QTY	PART	DESCRIPTION
1	1	222000-1	FRAME	18	1	501037	NYLON NUT
2	7	500444	CARRIAGE BOLT	19	5	451172	HYDRAULIC FITTING
3	5	223001	HOSE ATTACHMENT	20	2	451355	HYDRAULIC FITTING
4	1	466000	CUSHION VALVE	21	2	466989	VALVE
5	10	501030	NYLON NUT	22	6	451260	HYDRAULIC FITTING
6	4	500014	BOLT	23	2	451171	HYDRAULIC FITTING
7	1	223003	PIVOT AXLE	24	1	450972	HYDRAULIC FITTING
8	4	500443	CARRIAGE BOLT	25	2	322299	GREASE FITTING
9	4	501022	FLANGE NUT	26	1	222042	TRIGGER ARM TIP
10	2	465063	VALVE	27	1	222041	TRIGGER ARM
11	1	501031	NYLON NUT	28	1	500173	BOLT
12	1	500334	BOLT	29	2	500570	SHOULDER SCREW
13	1	222001	VALVE SUPPORT	30	1	502048	LOCK WASHER
14	9	501032	FLANGE NUT	31	1	222044	TRIGGER ARM ADJUSTMENT
15	2	500084	BOLT	32	1	222043	DUMPING TABLE AXIS
16	6	500016	BOLT	33	1	502006	FLAT WASHER
17	1	500044	BOLT	34	2	451261	HYDRAULIC FITTING

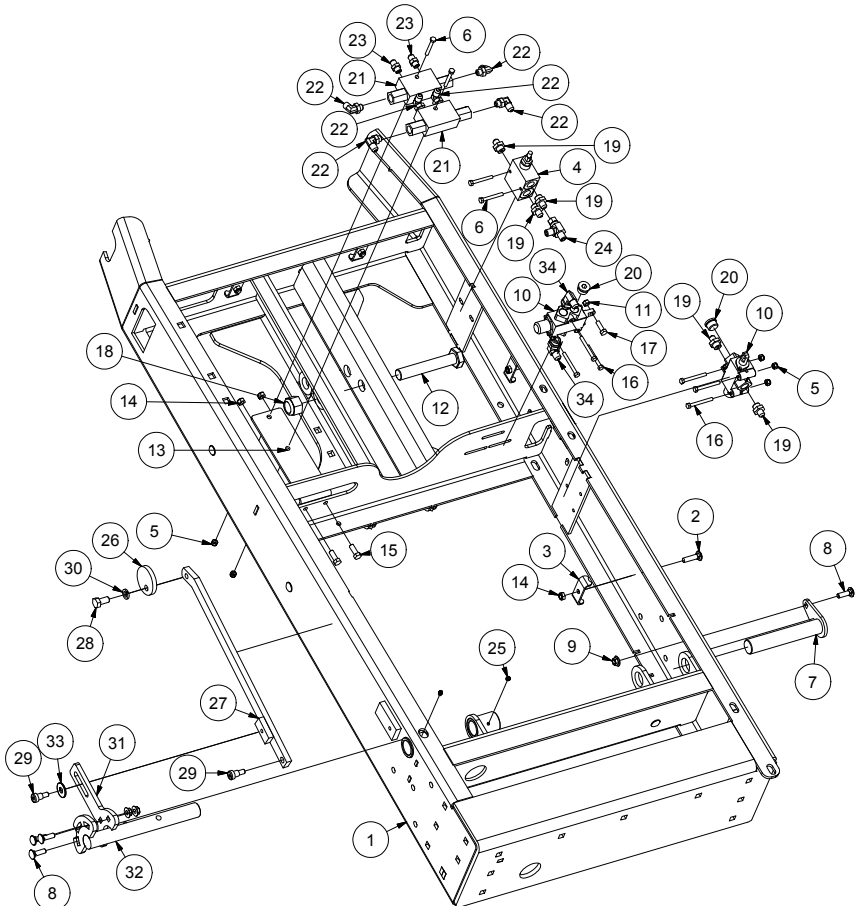

2 - PLASTIC ROLLER SUPPORT, COUPLING HAND AND TONGUE

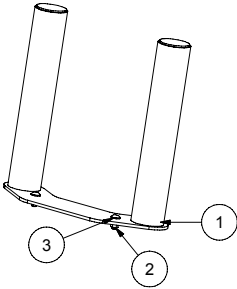

ROLLER SUPPORT

PARTS LIST			
ITEM	QTY	PART	DESCRIPTION
1	2	224082-1	PLASTIC ROLLER SUPPORT
2	2	501022	FLANGE NUT
3	2	500442	CARRIAGE BOLT

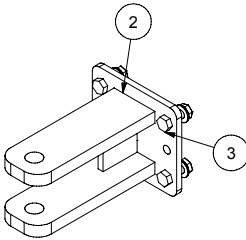

COUPLING HAND

PARTS LIST			
ITEM	QTY	PART	DESCRIPTION
2	1	223076	COUPLING HAND
3	4	500177	BOLT
6	4	501024	FLANGE NUT

TONGUE

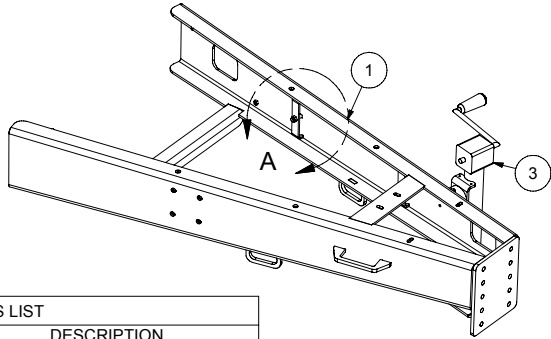

PARTS LIST			
ITEM	QTY	PART	DESCRIPTION
1	1	222002	TONGUE
2	2	501032	NYLON NUT
3	1	322457	JACK
4	2	223001	HOSE ATTACHMENT
5	2	500444	CARRIAGE BOLT
23	2	507011	WELD NUT

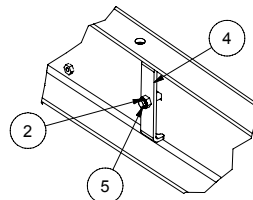

DETAIL A

PARTS LIST			
ITEM	QTY	PART	DESCRIPTION
1	1	223084	DOMPING TABLE LOCK
2	1	500088	BOLT
3	5	501022	FLANGE NUT
4	4	500443	CARRIAGE BOLT
5.1	2	481400	HUB
5.2	2	320002	COTTER PIN
5.3	2	501076	CASTLE NUT
6	13	501024	FLANGE NUT
7	9	500175	BOLT
8	4	500501	CARRIAGE BOLT
9	1	223080-1	COMPLETE RIGHT AXLE
10	1	223081-1	COMPLETE LEFT AXLE
11	2	481604	TIRE AND RIM

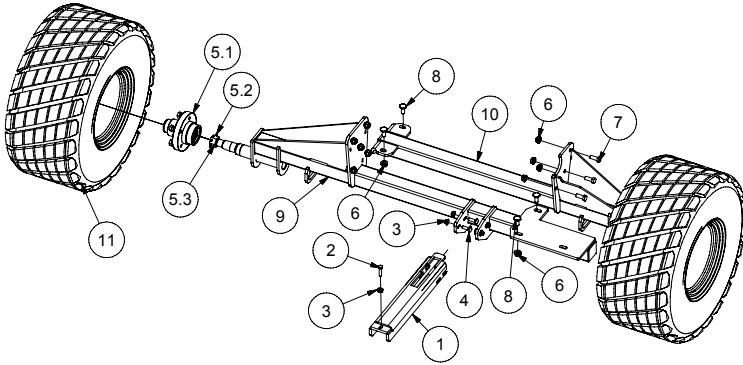

PARTS LIST			
ITEM	QTY	PART	DESCRIPTION
1	1	481400	HUB
2	1	303035	BEARING
3	1	303036	BEARING
4	1	303037	ROLLING BEARING CAGE
5	1	303034	BEARING
6	1	303077	SEAL
7	1	481000	DUST CAP
8	5	507010	WHEEL BOLT

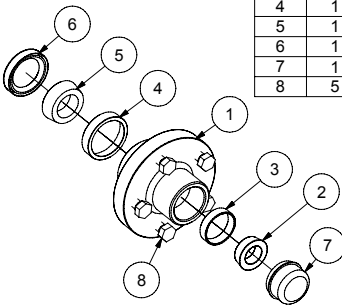

4 - STRETCHER SUPPORT ARM

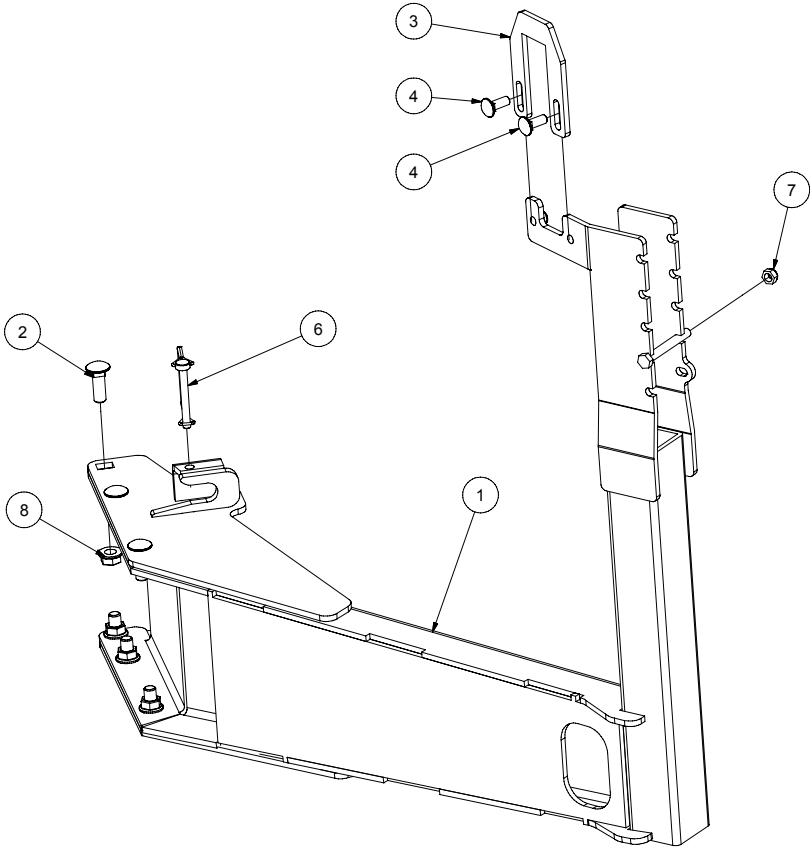

PARTS LIST

ITEM	QTY	PART	DESCRIPTION
1	1	223067	ARM
2	6	500502	CARRIAGE BOLT
3	1	223068	REINFORCEMENT
4	2	500442	CARRIAGE BOLT
6	1	320021	LOCK
7	3	501032	NYLON NUT
8	6	501024	FLANGE NUT
23	1	500099	BOLT

5 - STRETCHER SUPPORT

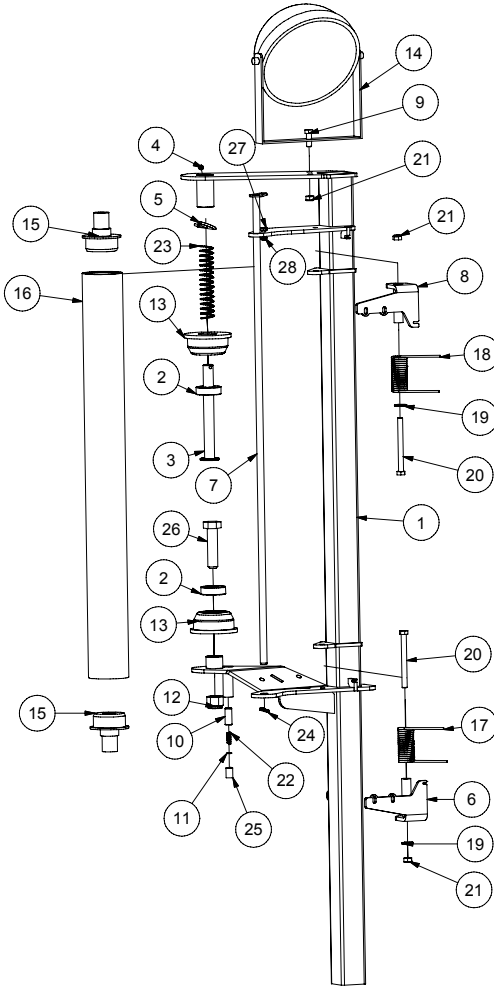

PARTS LIST				PARTS LIST			
ITEM	QTY	PART	DESCRIPTION	ITEM	QTY	PART	DESCRIPTION
1	1	224076	STRETCHER'S POST	15	2	306018	AXLE
2	2	303012	BEARING	16	1	224084	RUBBER ROLLER
3	1	224077	SHAFT	17	1	304007	SPRING
4	1	322299	GREASE FITTING	18	1	304008	SPRING
5	1	320039	HITCH PIN	19	2	502004	FLAT WASHER
6	1	224078	SPRING HOLDER	20	2	500104	BOLT
7	1	224079	ROD	21	3	501032	NYLON NUT
8	1	224080	SPRING HOLDER	22	1	304023	SPRING
9	1	500084	BOLT	23	1	304009	SPRING
10	1	224081	TEFLON BREAK	24	1	320002	PIN
11	1	502001	FLAT WASHER	25	1	507036	ALLEN SET SCREW
12	1	501036	NYLON NUT	26	1	500289	BOLT
13	2	224082	ROLLER SUPPORT	27	1	500004	BOLT
14	1	319880	WORK LIGHT	28	1	501030	NYLON NUT

6- STRETCHER

PARTS LIST

ITEM	QTY	PART	DESCRIPTION
1	2	224067	BEARING CUP
2	1	279102	GEAR
3	1	279100	GEAR
4	2	224068	SPACER
5	2	500017	BOLT
6	2	279004	ALUMINUM ROLLER
7	1	224065	LOWER BRACKET
8	1	224066	UPPER BRACKET
9	1	224070	ROD
10	5	500004	BOLT
11	2	224067	BEARING CUP
12	1	224071	SHIELD
13	8	501030	NYLON NUT
14	4	500006	BOLT
15	1	224075	PLASTIC SHIELD
16	2	320022	KEY
17	2	501020	FLANGE NUT
18	1	322299	GREASE FITTING
19	4	303018	BEARING
20	2	501022	FLANGE NUT
21	1	279103	GEAR
22	1	279104	GEAR

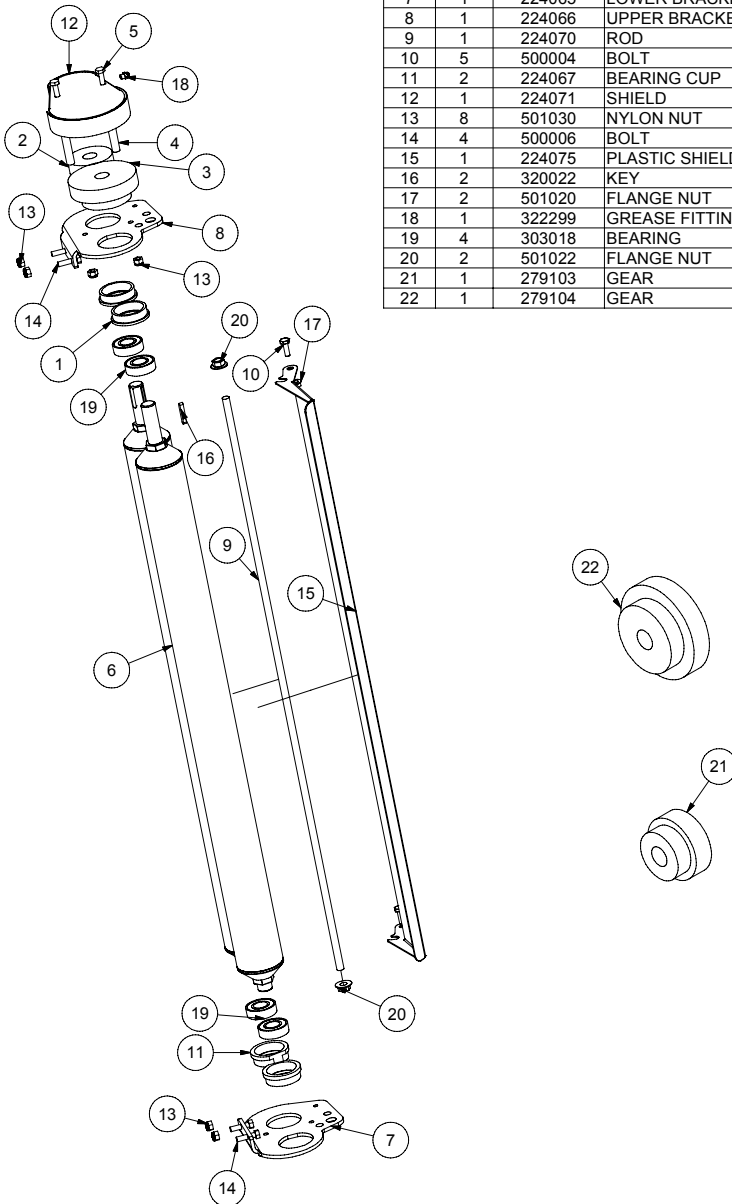

7- DUMPING TABLE

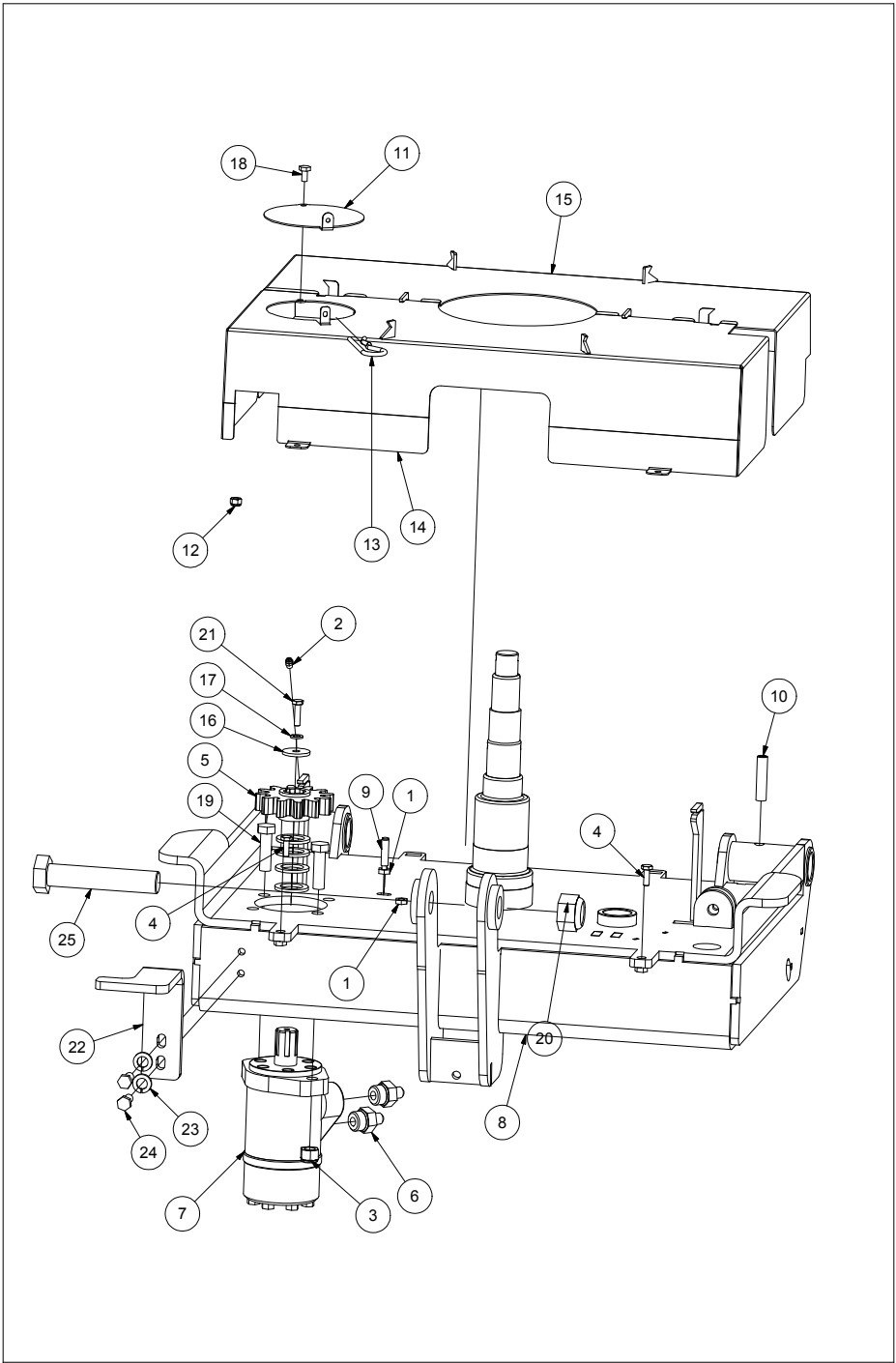

7 - DUMPING TABLE

PARTS LIST			
ITEM	QTY	PART	DESCRIPTION
1	4	315007	PLASTIC NUT
2	1	322299	GREASE FITTING
3	2	501034	NYLON NUT
4	2	500004	BOLT
5	1	224015-2	GEAR
6	2	451173	HYDRAULIC FITTING
7	1	469147	HYDRAULIC MOTOR
8	1	222005	TABLE
9	1	315004	WIRED SENSOR
10	1	320074	SPRING PIN
11	1	223018	CAP
12	1	501030	NYLON NUT
13	1	320010	HITCH PIN CLIP
14	1	222045	FRONT GUARD
15	1	222046	REAR GUARD
16	1	210629	WASHER
17	1	502046	LOCK WASHER
18	1	500001	BOLT
19	2	500179	BOLT
20	1	501037	NYLON NUT
21	1	500006	BOLT
22	1	222053	SHUTTER
23	2	502045	LOCK WASHER
24	2	500084	BOLT
25	1	500333	BOLT

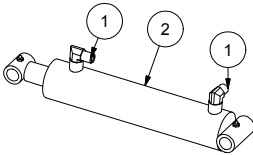

PARTS LIST			
ITEM	QTY	PART	DESCRIPTION
1	2	450712	HYDRAULIC FITTING
2	1	467029	DUMP. TABLE CYLINDER
3	2	322295	GREASE FITTING

7 - DUMPING TABLE

PARTS LIST			
ITEM	QTY	PART	DESCRIPTION
1	1	224035	KEY
2	1	320017	COTTER PIN
3	8	500211	BOLT
4	1	501076	CASTLE NUT
5	1	300509-S	CONIC GEAR
6	1	501120	CASTLE NUT
7	1	223022-2	GEAR
8	1	315004	SENSOR
9	2	315007	PLASTIC NUT
10	1	481404	HUB
11	1	320002	COTTER PIN
12	1	303493	BEARING CUP
13	1	501902	WHEEL NUT
14	1	303492	BEARING CUP
15	1	303491	BEARING
16	1	303490	DUST CAP
17	1	303494	BEARING

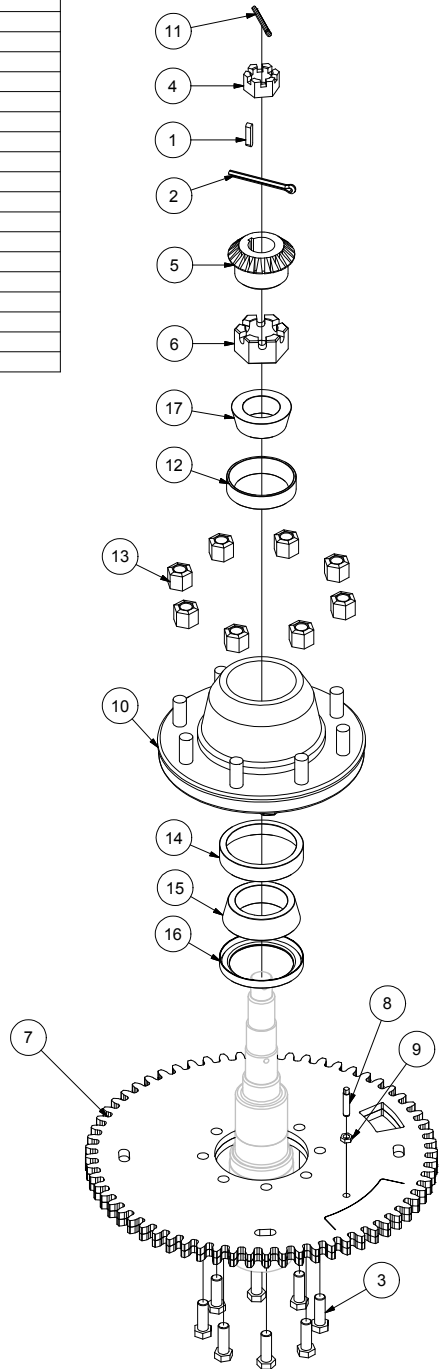

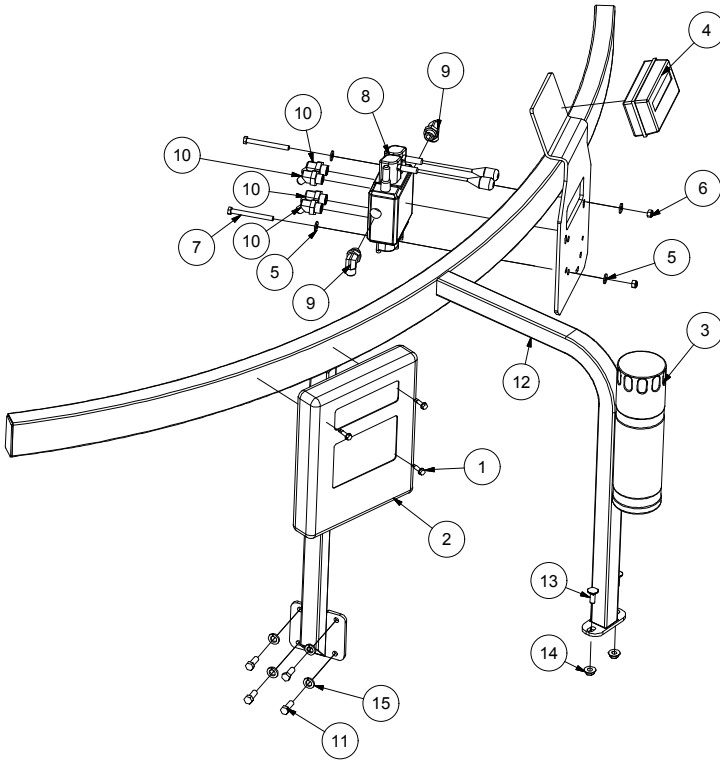

PARTS LIST			
ITEM	QTY	PART	DESCRIPTION
1	3	507006	SELF-DRILLING SCREW
2	1	325109-1	OPERATOR'S MANUAL BOX
3	1	325120	CYLINDER BOX
4	1	315006	COUNPTER
5	4	502014	FLAT WASHER
6	2	501031	NYLON NUT
7	2	500059	BOLT
8	1	466015	VALVE
9	2	451265	HYDRAULIC FITTING
10	4	451227	HYDRAULIC FITTING
11	4	500084	BOLT
12	1	222003	SHIELD
13	2	500442	CARRIAGE BOLT
14	2	501022	FLANGE NUT
15	4	502045	LOCK WASHER

9 - ROTARY TABLE

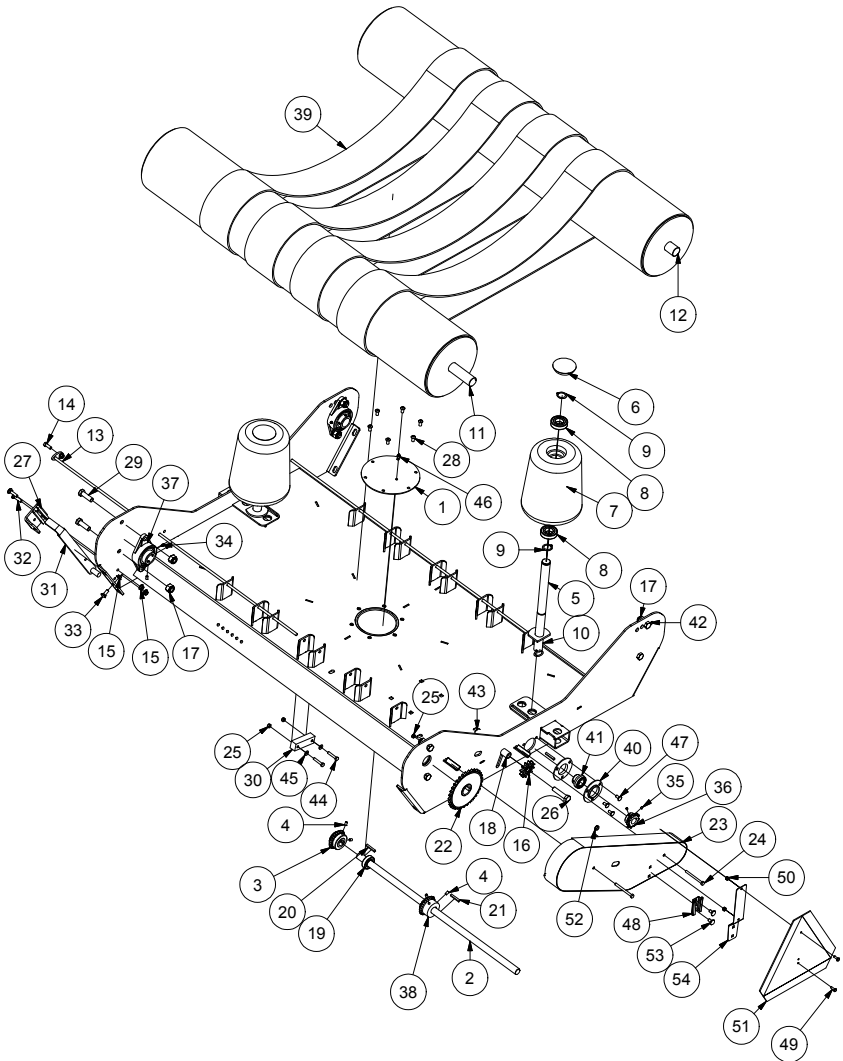

PARTS LIST			
ITEM	QTY	PART	DESCRIPTION
1	1	223182	TAB
2	1	222040	ROTATING ROLL'S SHAFT
3	1	300511M1-S	GEAR
4	14	507005	ALLEN SET SCREW
5	2	223026	ROLLER SUPPORT STAND SHAFT
6	2	325107	PLASTIC HOLE PLUG
7	2	325112	PLASTIC ROLLER
8	4	303045	BEARING
9	4	320006	SNAP RING
10	2	320039	PIN
11	1	223039	DRIVING ROLLER
12	3	223040	DRIVED ROLLER
13	2	230041	ROD
14	2	500084	BOLT
15	5	501022	FLANGE NUT
16	1	301101	SPROCKET
17	8	501035	NYLON NUT
18	1	485548	ADJUSTMENT WASHER
19	1	303989	BEARING
20	2	222015	KEY
21	1	325141-1	KEY
22	1	223035	SPROCKET
23	1	223042	CHAIN GARD ON PIV.TABLE
24	2	500060	BOLT
25	4	501031	NYLON NUT
26	1	500249	BOLT
27	2	222038	LOCK SUPPORT
28	6	507065	BUTTON HEAD SCREW
29	4	500246	BOLT
30	1	485576	STOPPER
31	1	222039	LOCK
32	2	500444	CARRIAGE BOLT
33	1	500442	CARRIAGE BOLT
34	4	322299	GREASE FITTING
35	2	507003	ALLEN SET SCREW
36	1	301050	SPROCKET
37	4	303024	BEARING
38	1	300511	GEAR
39	4	322603	BELT
40	2	303050	FLANGE BEARING
41	1	303000	BEARING
42	4	500245	BOLT
43	1	501025	FLANGE NUT
44	2	500050	BOLT
45	2	502014	FLAT WASHER
46	1	322295	GREASE FITTING
47	3	500360	CARRIAGE BOLT
48	1	210758	MOUNTING SUPPORT
49	2	500004	BOLT
50	2	501030	NYLON NUT
51	1	325145	SECURITY TRIANGLE
52	2	501032	NYLON NUT
53	2	500440	CARRIAGE BOLT
54	1	222055	TRIANGLE SUPPORT

9 - ROTARY TABLE AND CUT AND HOLD

PARTS LIST			
ITEM	QTY	PART	DESCRIPTION
1	1	222006	CUT AND HOLD UPPER SECTION
2	1	222007	CUT AND HOLD BOTTOM SECTION
3	2	223049	HOLDING ROLLER
4	1	222008	ROTARY TABLE

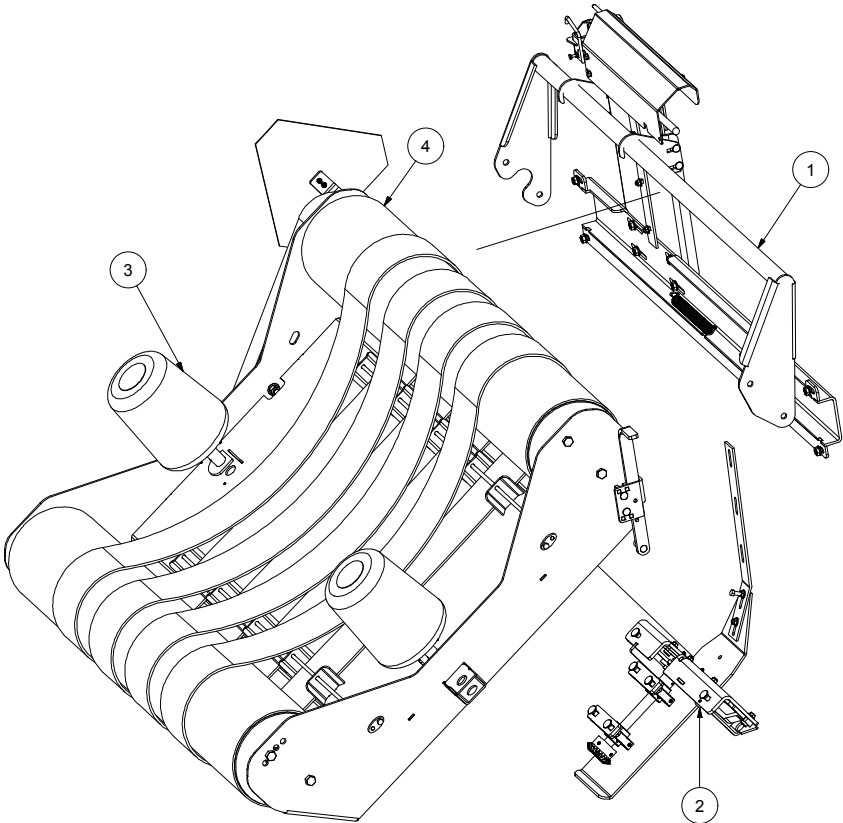

9 - CUT AND HOLD

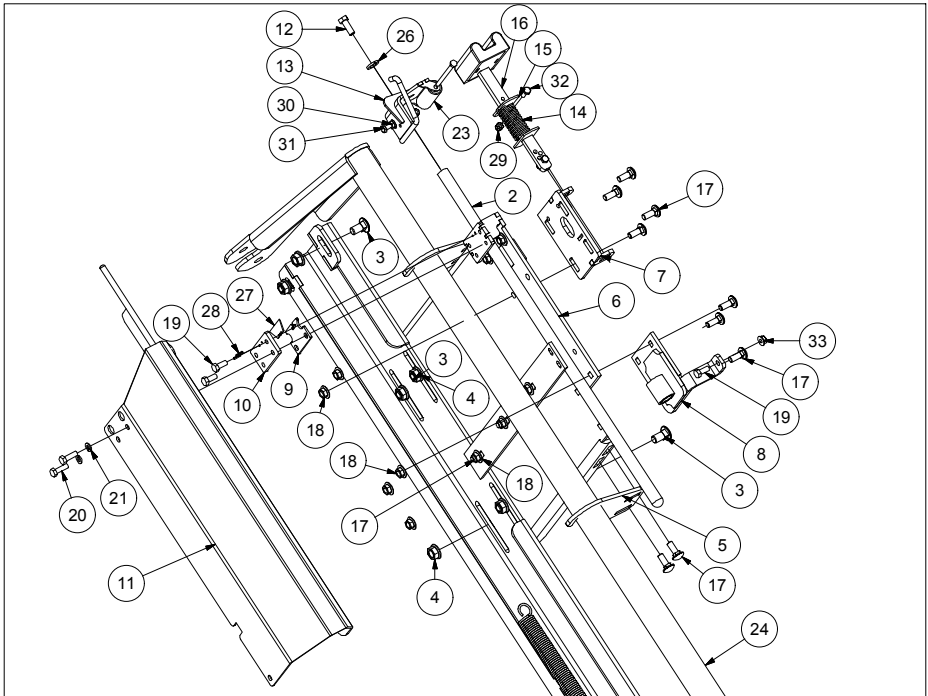

PARTS LIST			
ITEM	QTY	PART	DESCRIPTION
1	1		ATTECHEMENT PLATE
2	1	222023	HAMMER SHAFT
3	8	500500	CARRIAGE BOLT
4	8	501024	FLANGE NUT
5	2	222025	HOOK
6	1	222037	HAMMER AND BUFFER SUPPORT
7	1	222026	BUFFER SUPPORT
8	1	222027	HAMMER SUPPORT
9	1	222028	BLADE HOLDING PLATE
10	1	222029	BLADE MOUNTING PLATE
11	1	222030	COVER
12	1	500084	BOLT
13	1	222031	HAMMER'S PLATE
14	1	304010	SPRING
15	2	222033	SPRING'S PLATE
16	1	222034	RUBBER BUFFER
17	14	500442	CARRIAGE BOLT
18	16	501022	FLANGE NUT
19	3	500042	BOLT
20	2	500044	BOLT
21	2	502065	LOCK WASHER
22	1	304012	SPRING
23	1	222035	HAMMER'S ROLL
24	1	238009	PLASTIC CUT SUPPORT
25	1	500096	BOLT
26	1	502045	LOCK WASHER
27	1	325108	BLADE
28	2	320050	SPRING PIN
29	3	501030	NYLON NUT
30	1	501020	FLANGE NUT
31	1	500006	BOLT
32	2	500004	BOLT
33	1	501021	FLANGE NUT

9 - CUT AND HOLD

PARTS LIST			
ITEM	QTY	PART	DESCRIPTION
1	1	238008	RACK AND PINION
2	1	222010	SPACER
3	2	222011	SPACER
4	1	222012	RACK AND PINION HOLDING PLATE
5	1	222013	CAME
6	1	222014	CAM SHAFT
7	1	300511	GEAR
8	2	507005	ALLEN SET SCREW
9	2	222015	KEY
10	2	222016	BEARING MOUNTING PLATE
11	2	303028	BEARING
12	1	222017	ACTIVATION PLATE
13	1	304030	SPRING
14	1	222018	TRANSFER PLATE
15	1	222019	TRANSFER BRACKET
16	2	500570	SHOULDER SCREW
17	7	501022	FLANGE NUT
18	1	222020	RACK AND PINION PLATE
19	2	222021	RACK AND PINION HOOK
20	6	501024	FLANGE NUT
21	2	501021	FLANGE NUT
22	2	500403	CARRIAGE BOLT
23	4	500503	CARRIAGE BOLT
24	1	222022	CAM FINGER
25	1	303021-1	BEARING
26	1	502004	FLAT WASHER
27	1	500082	BOLT
28	2	500444	CARRIAGE BOLT
29	1	500442	CARRIAGE BOLT
30	4	507003	ALLEN SET SCREW
31	4	322299	GREASE FITTING
32	2	500501	CARRIAGE BOLT
33	1	500092	BOLT
34	1	320055	RETAINING RING

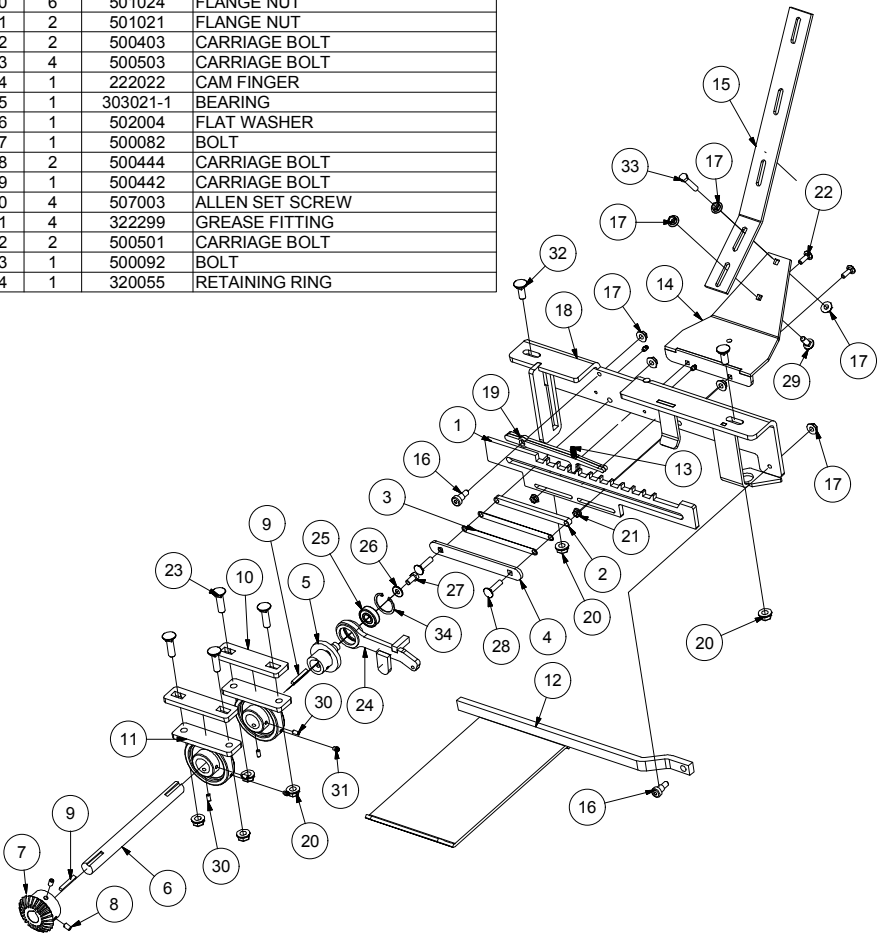

11 - LOADING ARM

PARTS LIST			
ITEM	QTY	PART	DESCRIPTION
1	1	223058	LOCK PIN
2	1	304010	SPRING
3	1	322299	GREASE FITTING
4	1	223059	OUTER FORK
5	2	502004	FLAT WASHER
6	4	500088	BOLT
7	4	501032	NYLON NUT
8	2	322299	GREASE FITTING
9	1	223087-1	CAM
10	1	223055	LOCK
11	1	223056	BALE STOPPER
12	3	500501	CARRIAGE BOLT
13	3	501024	FLANGE NUT
14	1	223057-1	LOADING ARM FRAME
15	1	303051	BUSHING

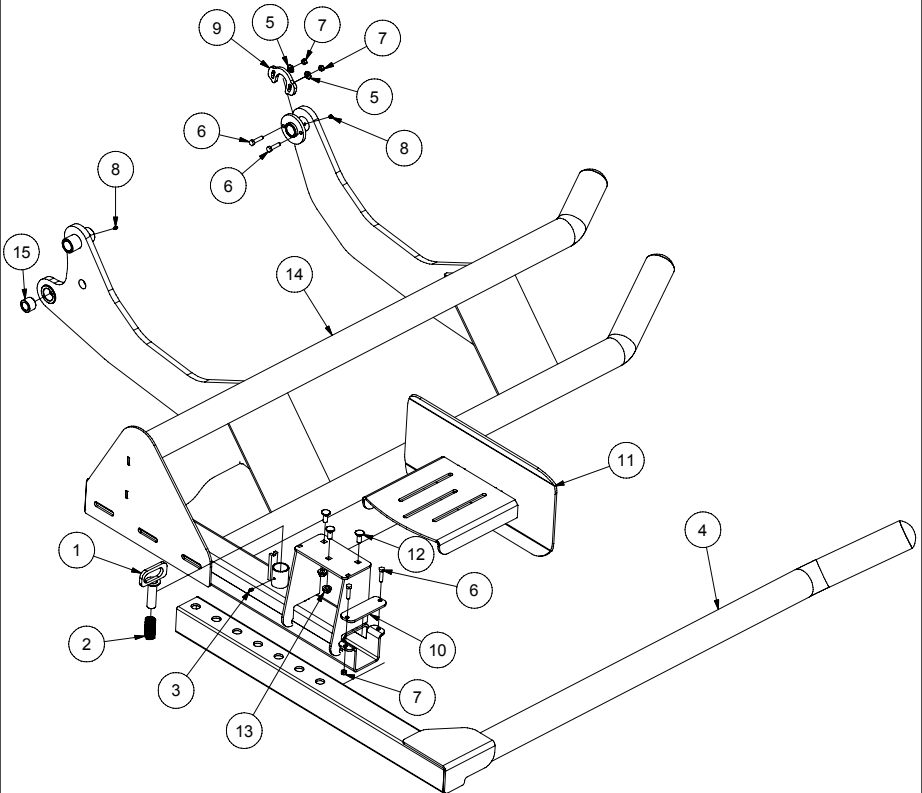

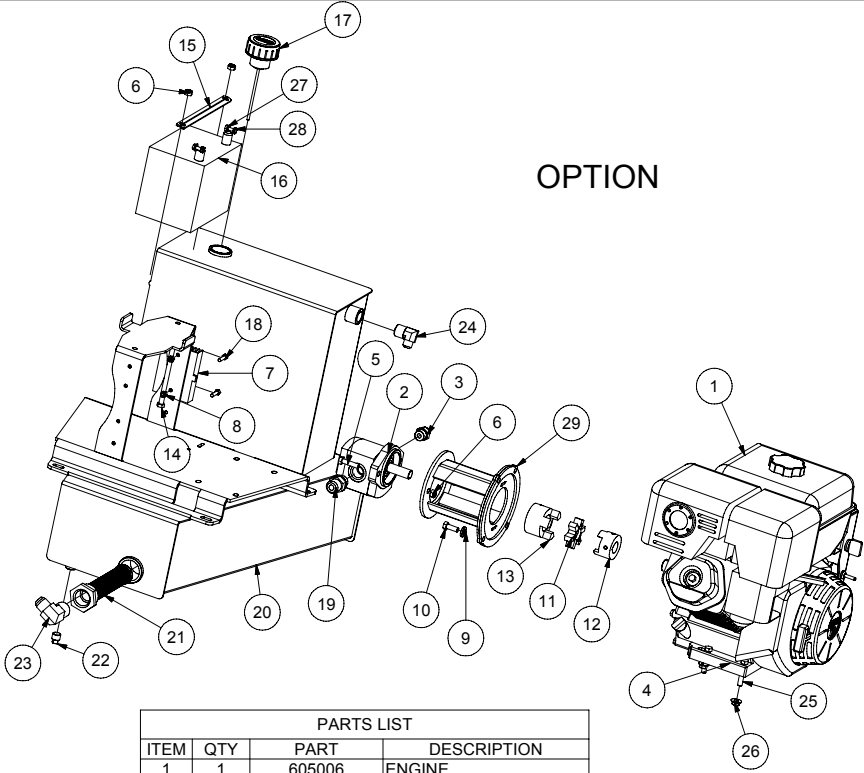

PARTS LIST			
ITEM	QTY	PART	DESCRIPTION
1	1	605006	ENGINE
2	1	468495-468002	PUMP
3	1	451179	HYDRAULIC FITTING
4	4	502004	FLAT WASHER
5	2	500088	BOLT
6	4	501032	NYLON NUT
7	1	605009	VOLTAGE REGULATOR
8	4	501030	NYLON NUT
9	4	502045	LOCK WASHER
10	4	500084	BOLT
11	1	322020	INSERT
12	1	322050	COUPLING
13	1	322042	COUPLING
14	2	500114	BOLT
15	1	224110	BATTERY HOLDER
16	1	470113	BATTERY
17	1	470112	TANK CAP
18	2	500006	BOLT
19	1	451190	HYDRAULIC FITTING
20	1	224108	TANK
21	1	470990	STRAINER
22	1	470117	DRAIN PLUG
23	1	450725	HYDRAULIC FITTING
24	1	450717	HYDRAULIC FITTING
25	4	500092	BOLT
26	4	501022	FLANGE NUT
27	2	501020	FLANGE NUT
28	2	500004	BOLT
29	1	322008	PUMP ADAPTER

11 - LOADING ARM

PARTS LIST			
ITEM	QTY	PART	DESCRIPTION
1	1	450712	HYDRAULIC FITTING
2	1	467152	HYDRAULIC CYLINDER
3	2	322299	GREASE FITTING
4	2	223098	CYLINDER AXLE
5	2	320005-1	SNAP RING
6	2	223099	WASHER
7	1	450712M	HYDRAULIC FITTING

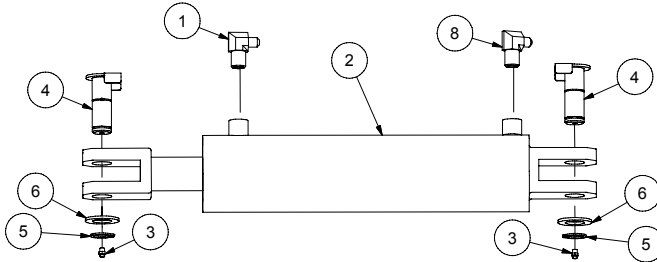

PARTS LIST			
ITEM	QTY	PART	DESCRIPTION
1	2	501024	FLANGE NUT
2	2	500501	CARRIAGE BOLT
3	2	500173	BOLT
4	2	502048	LOCK WASHER
5	1	223083	COUNTERWEIGHT
6	1	223082	SUPPORT

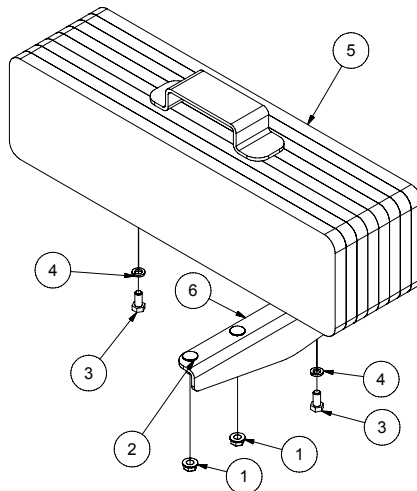

11 - LOADING ARM

PARTS LIST			
ITEM	QTY	PART	DESCRIPTION
1	1	223060	REAR ATTACHMENT
2	1	501024	FLANGE NUT
4	2	500501	CARRIAGE BOLT
5	1	223061	PIN
6	1	320010	LOCK
7	7	501024	FLANGE NUT
8	1	501032	NYLON NUT
9	1	500096	BOLT
15	5	500504	CARRIAGE BOLT

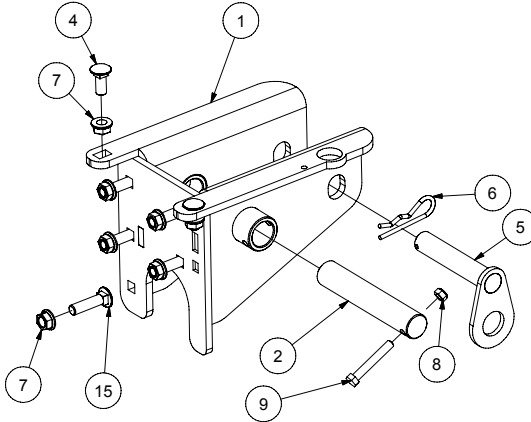

PARTS LIST			
ITEM	QTY	PART	DESCRIPTION
1	1	223063	FRONT ATTACHMENT
2	1	223066	PIN
3	6	500502	CARRIAGE BOLT
4	1	502004	FLAT WASHER
5	1	223065	LEVER
6	1	223064	SPACER
7	6	501024	FLANGE NUT
8	1	500096	BOLT
9	3	501032	NYLON NUT
10	2	500088	BOLT

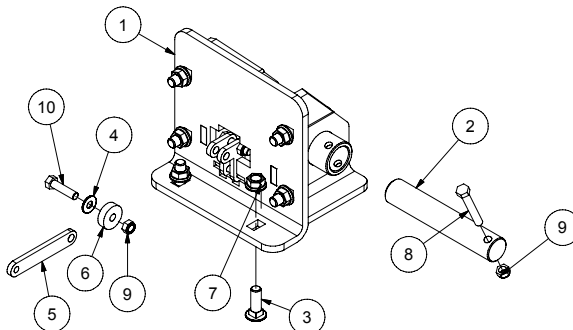

PARTS LIST			
ITEM	QTY	PART	DESCRIPTION
1	1	451229	HYDRAULIC FITTING
2	1	451230	HYDRAULIC FITTING
3	1	465918	HYDRAULIC VALVE
4	6	451226	HYDRAULIC FITTING
5	3	465492	VALVE PIECE CABLE
6	1	465490	CABLE

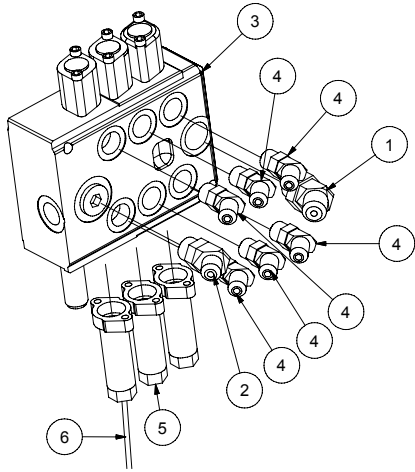

PARTS LIST			
ITEM	QTY	PART	DESCRIPTION
1	3	465494	CABLE CONTROL
2	1	222048	CONTROL CABLE ATTACHMENT
3	1	222049	CONTROL PLATE
4	2	222050	PLATE ATTACHMENT
5	1	210758	ASSEMBLY SUPPORT
6	2	500403	CARRIAGE BOLT
7	4	502065	LOCK WASHER
8	2	501001	NUT
9	6	507064	BUTTON HEAD SCREW
10	6	501049	NYLON NUT
11	6	501077-1	BOLT
12	2	500044	BOLT
13	4	502014	FLAT WASHER
14	1	222051	COMPLET CONTROL KIT

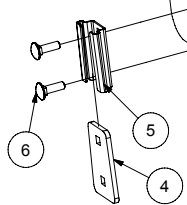
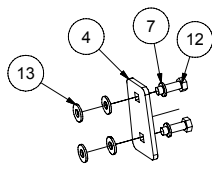
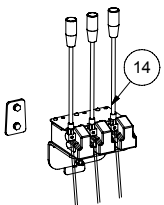
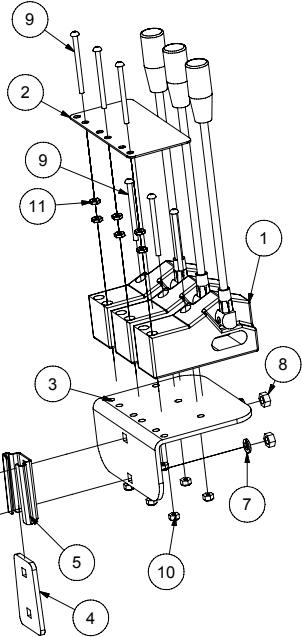



ANDERSON

12 - DROP OFF

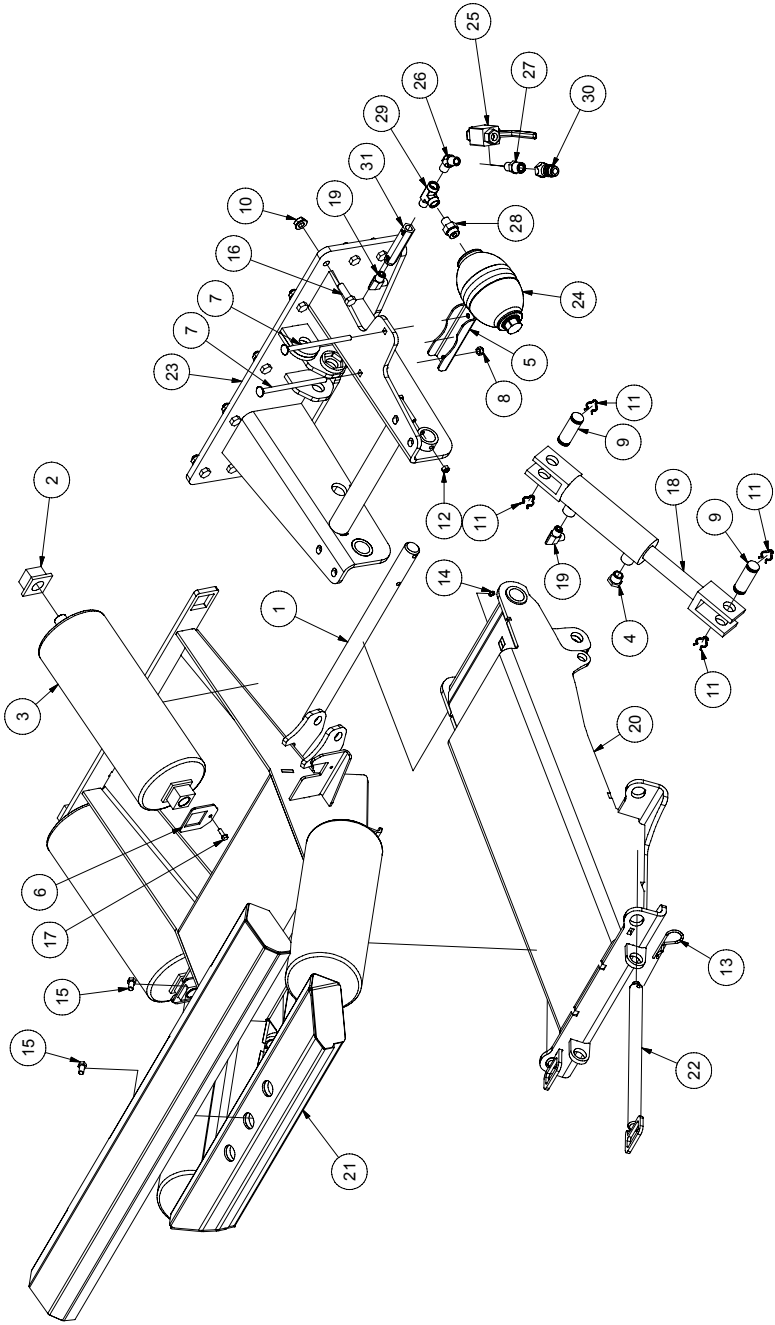

PARTS LIST		
ITEM	QTY	DESCRIPTION
1	1	DROP OFF AXLE
2	8	BUSHING
3	4	ROLLER
4	1	HYDRAULIC FITTING
5	1	SUPPORT
6	4	ROLLER LOCK
7	2	CARRIAGE BOLT
8	2	NYLON NUT
9	2	CYLINDER PIN
10	17	FLANGE NUT
11	4	CYLINDER CLIP PIN
12	1	NYLON NUT
13	4	HITCH PIN
14	4	GREASE FITTING
15	2	BOLT
16	9	BOLT
17	4	SELF-DRILLING SCREW
18	1	HYDRAULIC CYLINDER
19	2	HYDRAULIC FITTING
20	1	DROP OFF PLATE
21	1	TABLE
22	2	TABLE AXLE
23	1	DROP OFF ATTACHMENT
24	1	ACCUMULATOR
25	1	HYDRAULIC VALVE
26	1	HYDRAULIC FITTING
27	1	HYDRAULIC FITTING
28	1	HYDRAULIC FITTING
29	1	HYDRAULIC FITTING
30	1	HYDRAULIC FITTING
31	1	DOUBLE RELIEF VALVE

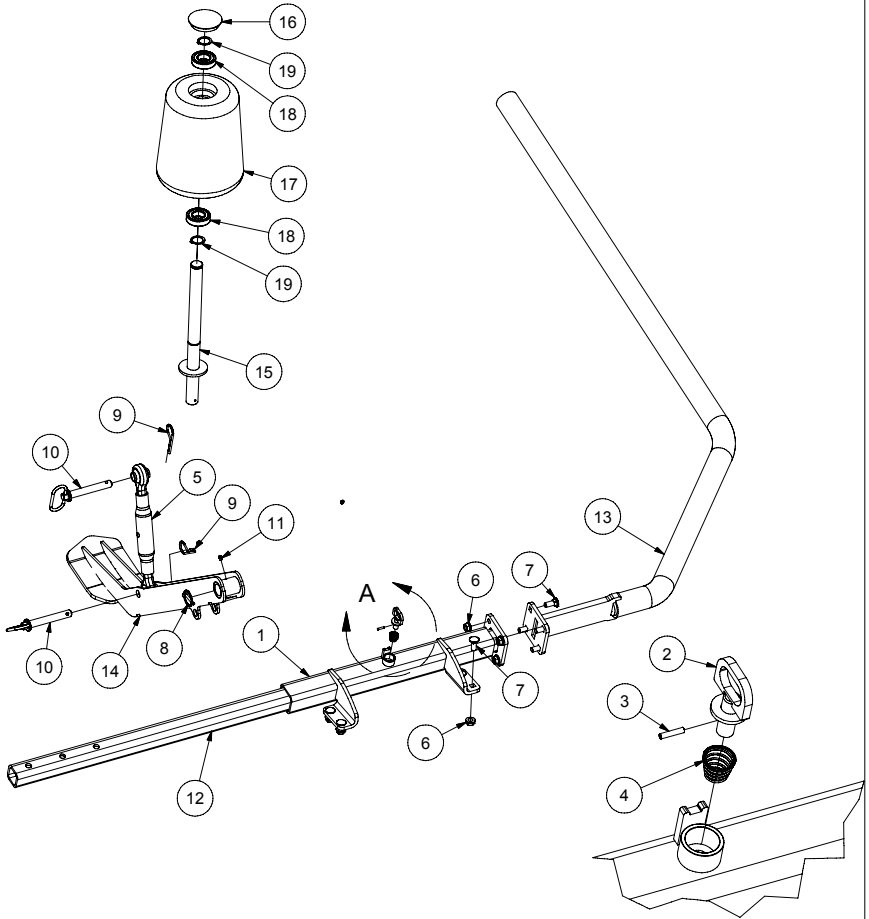

DETAIL A

PARTS LIST				
ITEM	QTY	PART	DESCRIPTION	
1	1	223093	ARM SUPPORT	
2	1	223185	ARM LOCK	
3	1	320073	SPRING PIN	
4	1	304034	SPRING	
5	1	224175	TOP LINK	
6	17	501024	FLANGE NUT	
7	8	500501	CARRIAGE BOLT	
8	1	320007	LINCHPIN	
9	4	320039	HITCH PIN	
10	2	320082	TOP LINK PIN	
11	4	322299	GREASE FITTING	
12	1	223183	FIXED PART OF ARM	
13	1	223184	REMOVABLE PART OF ARM	
14	2	223186-1	OUTRIGGER	
15	1	223187	ROLLER SUPPORT AXLE	
16	1	325107	CAP	
17	1	325112	ROLLER SUPPORT	
18	2	303045	BEARING	
19	2	320006	RETAINING RING	

13 - STABILIZER

PARTS LIST			
ITEM	QTY	PART	DESCRIPTION
1	5	500334	BOLT
2	2	223170	REAR STABILIZER
3	1	500333	BOLT
4	7	501057	HALF NYLON NUT
5	4	322299	GREASE FITTING
6	2	223171	FRONT STABILIZER
7	1	223172	REAR STABILIZER SUPPORT
8	14	501024	FLANGE NUT
9	14	500500	CARRIAGE BOLT
10	2	467026	CYLINDER
11	1	500330	BOLT
12	4	450712	HYDRAULIC FITTING
13	4	322295	GREASE FITTING
14	2	223173-1	STABILIZER SUPPORT
15	1	223304	ATTACHMENT
16	1	320043	COTTER PIN

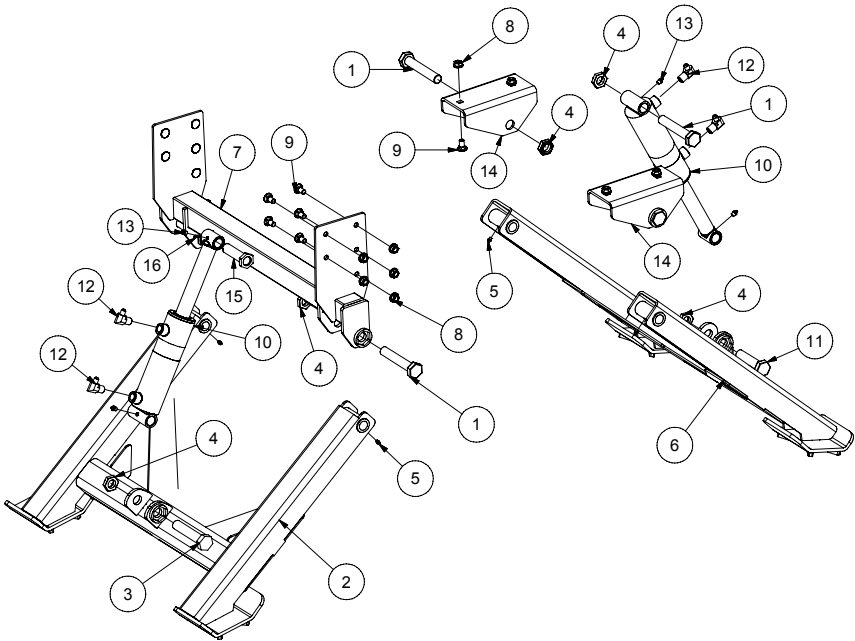



14 - DIAGRAMME HYDRAULIQUE 580 / 580 D 580M / 580 MD HYDRAULIC DIAGRAM

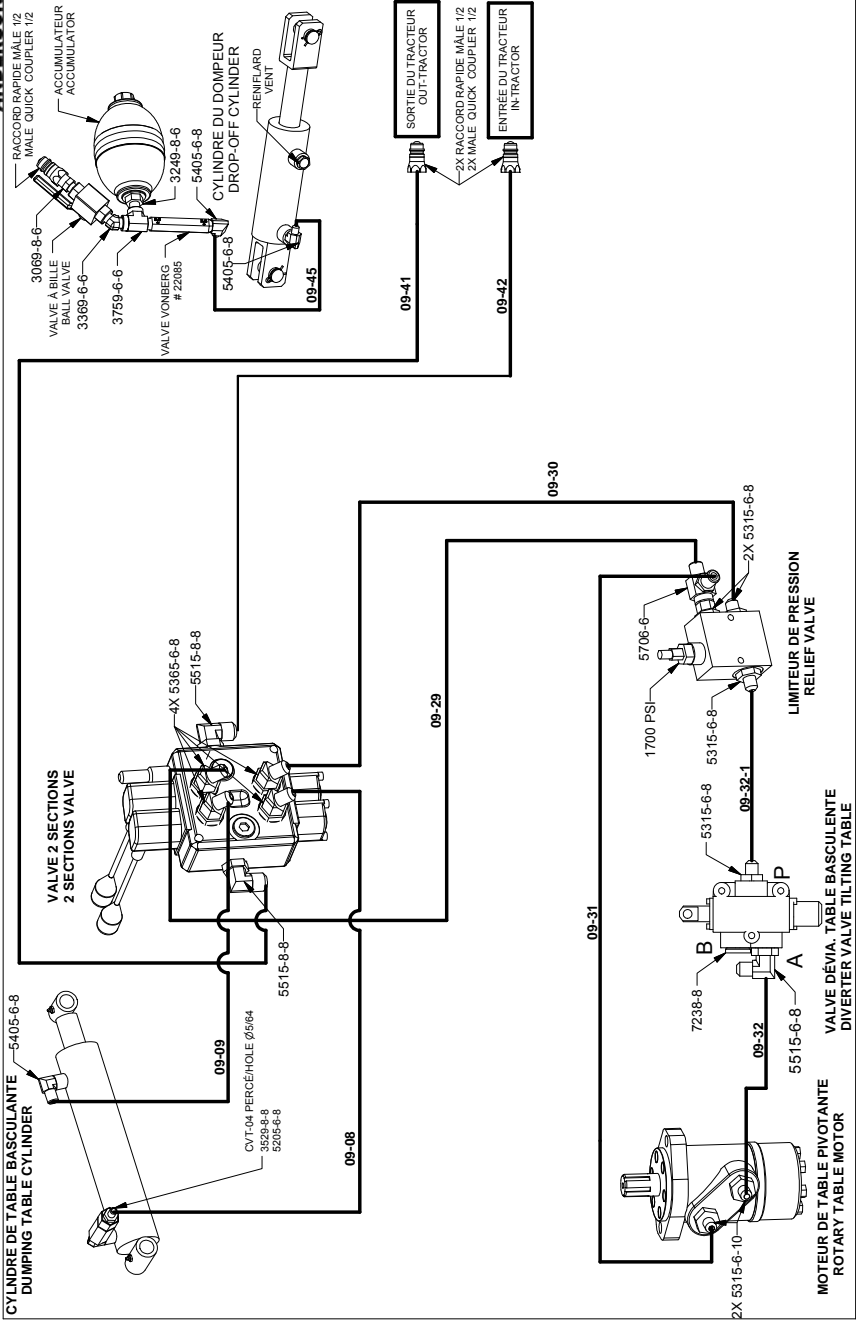



ANDERSON

14 - DIAGRAMME HYDRAULIQUE 580 ML / 580 MLD 580 L / 580 LD HYDRAULIC DIAGRAM

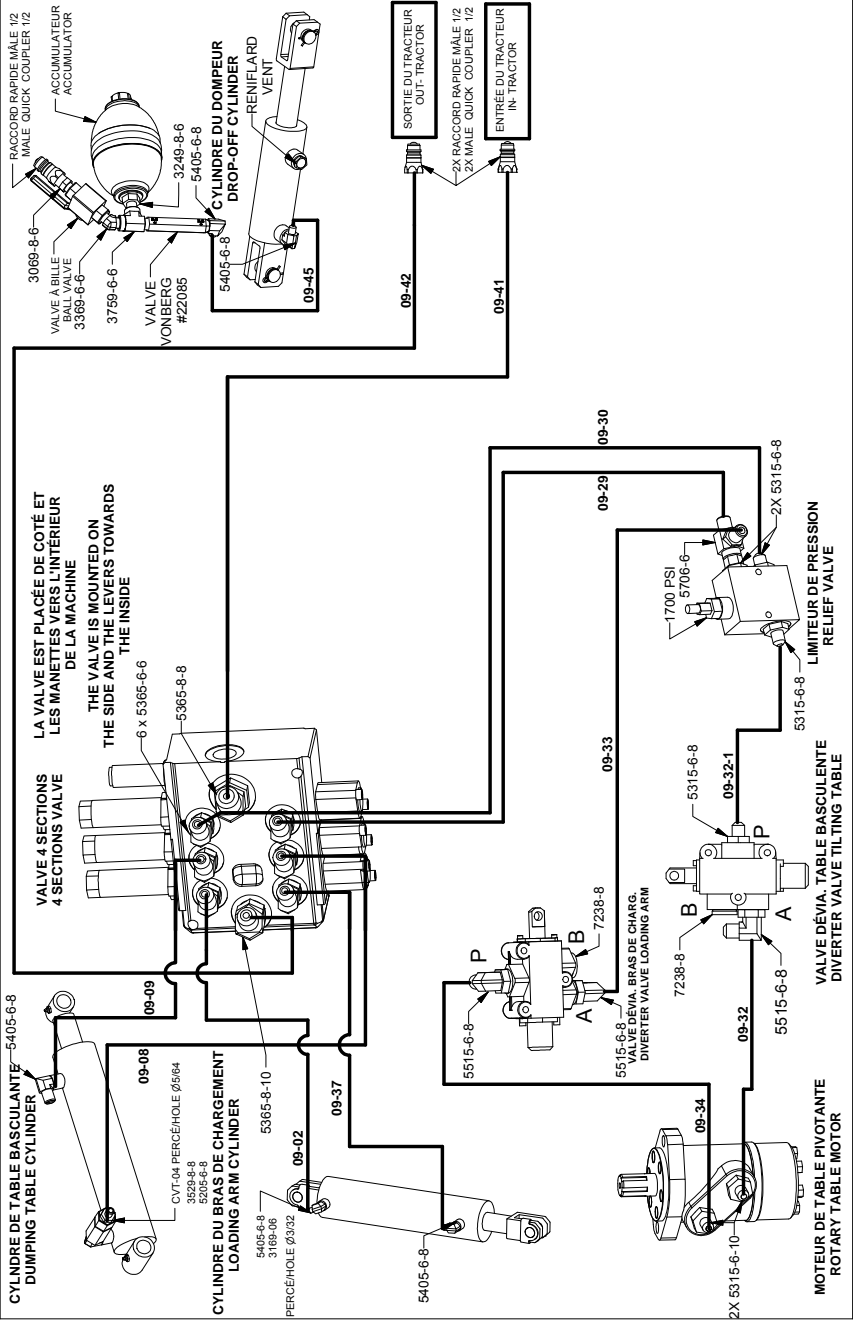



14 - DIAGRAMME HYDRAULIQUE 580M / 580 MD AVEC UNITÉ DE PUISSANCE 580 / 580 D WITH POWER UNIT HYDRAULIC DIAGRAM

ANDERSON

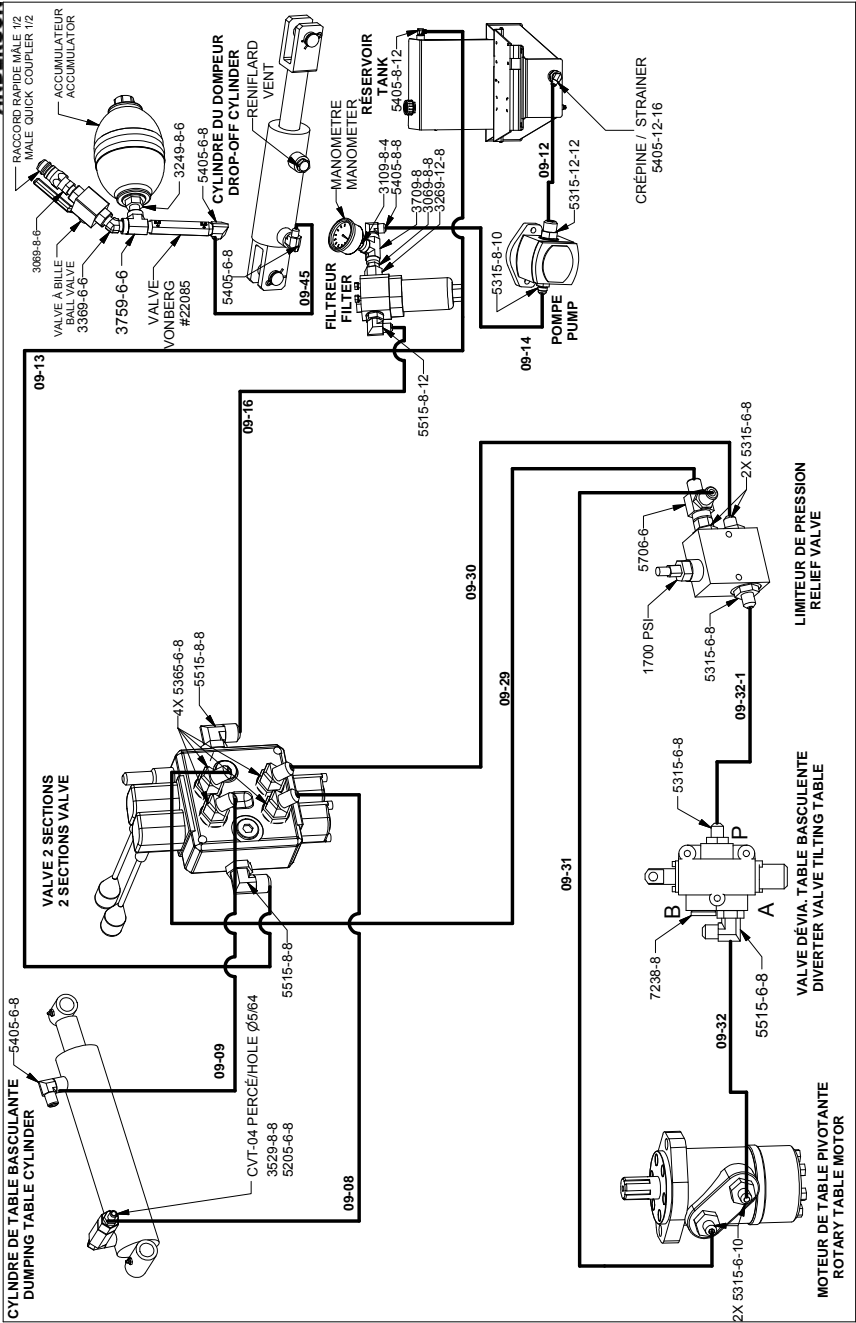



14 - DIAGRAMME HYDRAULIQUE 580 ML / 580 MLD AVEC UNITÉ DE PUISSANCE 580 L / 580 LD WITH POWER UNIT HYDRAULIC DIAGRAM

ANDERSON

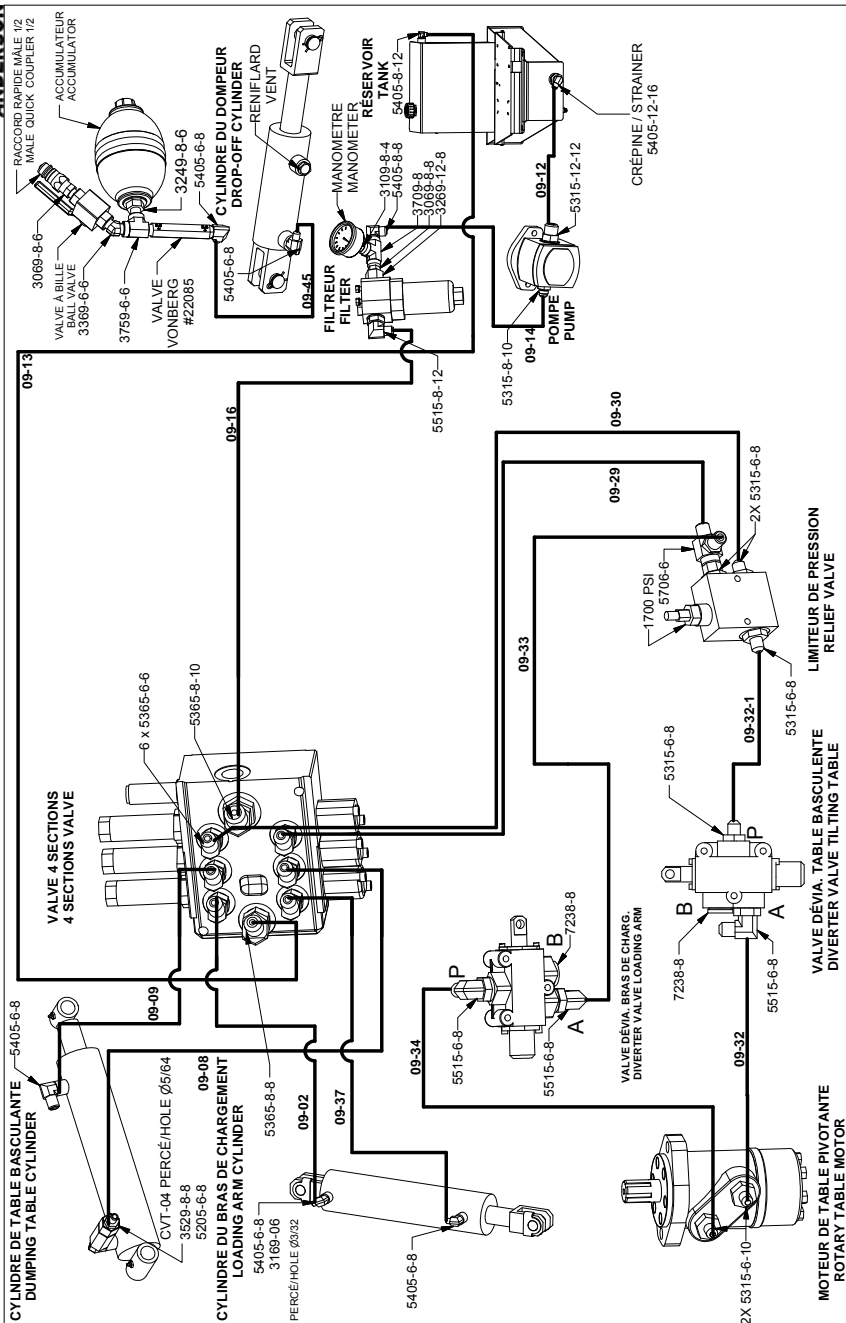



14 - DIAGRAMME HYDRAULIQUE 580 M / 580 MD AVEC PATTES ET UNITÉ DE PUISSANCE 580 / 580 D WITH OUTRIGGERS AND POWER UNIT HYDRAULIC DIAGRAM

ANDERSON

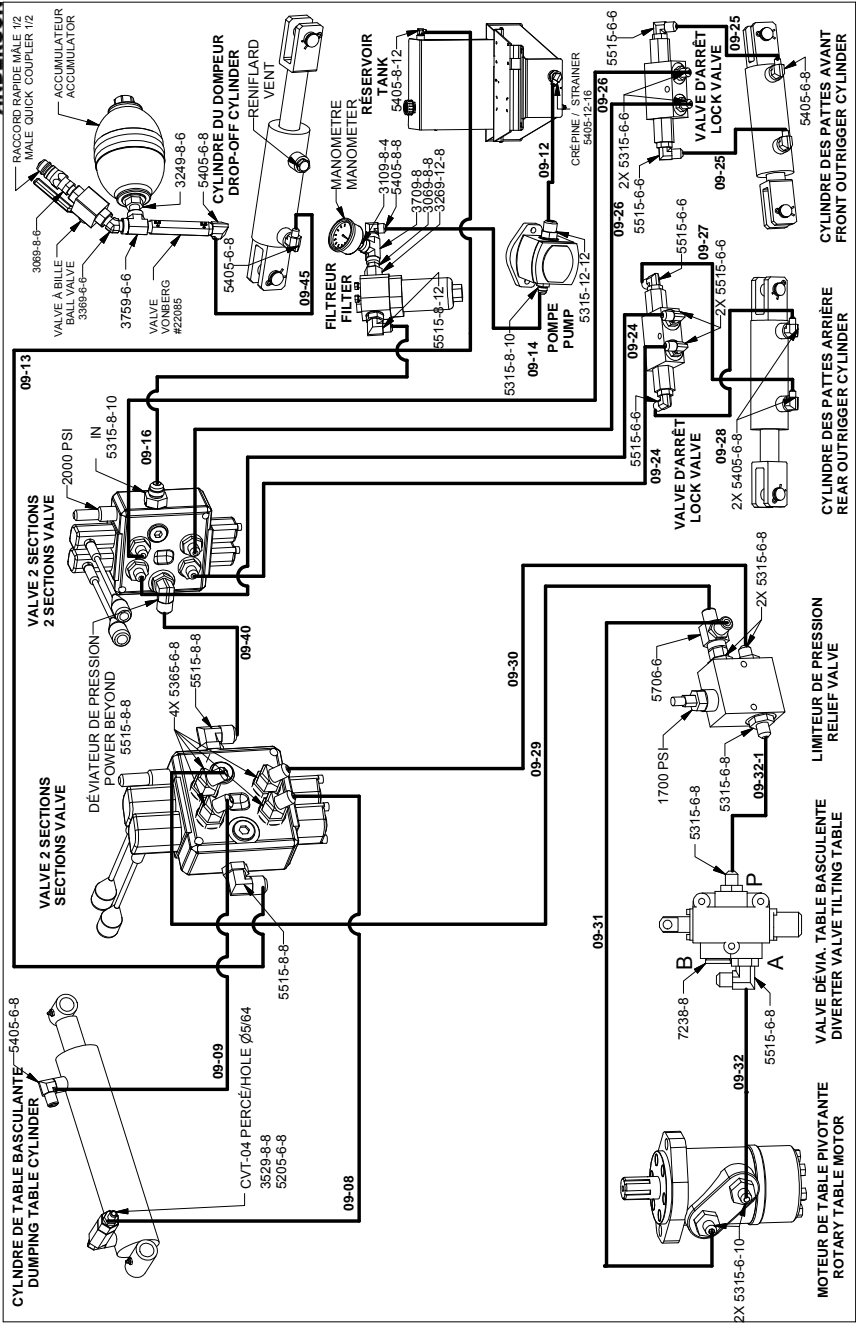

Groupes Anderson / Anderson Group, 5125 de la Plaisance Chesterville (Québec) G0P 1J0

Email : service@anderson-equipment.com



14 - LISTE DE BOYAUX / HOSE LIST

DESCRIPTION	NUMERO / NUMBER
09-02	223102-1
09-08	223108-1
09-09	223109-1
09-12	223158-1
09-13	223113
09-14	223159
09-16	223116
09-24	223124-1
09-25	223125
09-26	223126-1
09-27	223127-1
09-28	223128-1
09-29	223129-1
09-30	223130-1
09-31	223131
09-32	223132
09-32-1	223132-1
09-33	223133
09-34	223134
09-37	223137-1
09-40	223140
09-41	223141-1
09-42	223142-1
09-45	223178-1