

Fusion720 Inline wrapper

Diagnostic procedure A-FUS-012



- Hydraulic component localisation & specifications

A – Valve A (Control the loading section roller extraction)

B – Valve B (Control the bale kicker function in/out)

C – Valve C (Activate the hoop rotation by letting oil going to the flow divider built-in the control panel)

D – Individual wrapping mode “hoop vs rollers timing” flow divider

When running in individual wrapping mode, the hoop shall make 1,5X complete revolution, while the loading motorized roller make 1x revolution. If not time right, adjust the flow diverter valve indicated as “D” in the below picture.

E – Main valve SD5 #1

- Adjust relieve of the body valve @ 2400 PSI maximum pressure
- Xtractor section
- Hydraulic raising system section
- Traction wheels section
- Steering wheels section (Adjust stroke limiter turning LEFT @ 500 PSI and RIGHT @ 600 PSI)

F – Secondary valve SD5 #2

- Pusher section
- Cut & Hold section (Adjust stroke limiter during retraction @ 1200 PSI)
- Hoop rotation section
- Unloading roller sections

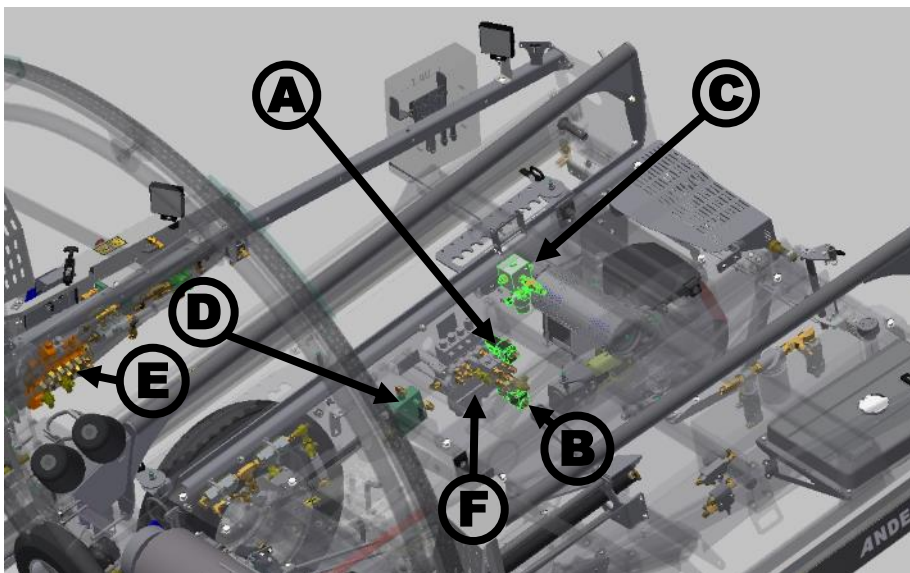

Fusion720 Inline wrapper

Diagnostic procedure A-FUS-012



- Hydraulic component localisation & specifications

HYDRAULIC ACTIONS	ELECTRO-HYDRAULIC COMPONENTS IN USE DURING ACTIONS
PUSHER MOVING FORWARD AND BACKWARD	SECTION #2 OF VALVE SD5 #2 (F)
HOOP ROTATION CLOCKWISE FOR INLINE WRAPPING (OIL FLOW GOING THROUGH THE FLOW DIVIDER WITHIN THE CONTROL PANEL)	VALVE C (C)
HOOP ROTATION CLOCKWISE AND ROLLER SECTION ROTATION DURING INDIVIDUAL BALE WRAPPING MODE	SECTION #1 OF VALVE SD5 #2 (F)
COUNTER CLOCK WISE HOOP ROTATION	SECTION #1 OF VALVE SD5 #2 (F)
LOADING SECTION ROLLER EXTRACTING OUT	SECTION #4 OF VALVE SD5#2 ET LA VALVE A (F) (A)
LOADING SECTION ROLLER RETRACTING WITHIN THE FRAME	SECTION #4 OF VALVE SD5#2 (F)
UNLOADING SECTION ROLLER MOVING UP	SECTION #4 OF VALVE SD5#2 (F)
UNLOADING SECTION ROLLER MOVING DOWN	SECTION #4 OF VALVE SD5#2 (F)
BALE KICKER GOING UP	SECTION #4 OF VALVE SD5#2 ET LA VALVE B (F) (B)
BALE KICKER GOING DOWN	SECTION #4 OF VALVE SD5#2 (F)
TRACTION WHEELS AUTO-REVERSE	SECTION #2 OF VALVE SD5#1 (E)
FILM « CUT & HOLD » IN AND OUT	SECTION #3 OF VALVE SD5 #2 (F)
STEERING WHEEL	SECTION #1 OF VALVE SD5#1 (E)

