

**BELT STOP INSTALLATION**

**Right side**

1- Before starting the installation make sure to have a pan to prevent oil spill. Remove the hose protector on hose 58 and 79C. Disconnect hose 79C from conveyor motor. Remove hose 58 (no longer useful).

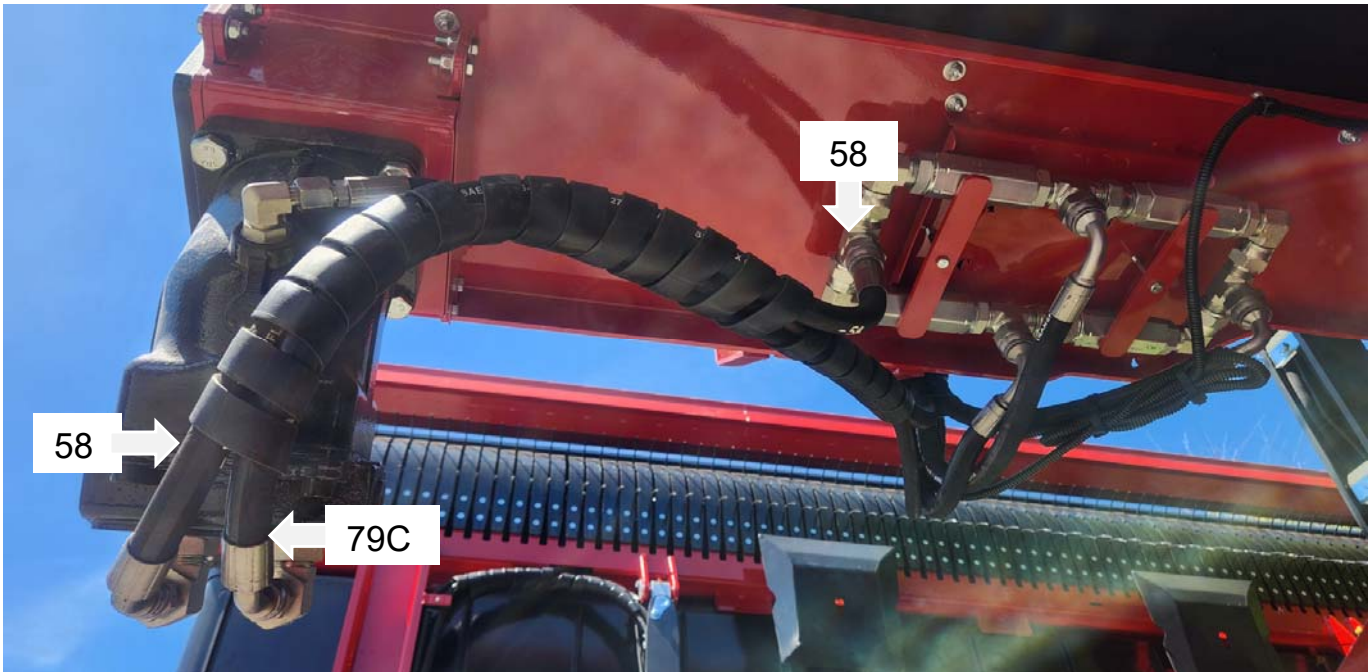

2- Bolt the valve to the conveyor frame near the conveyor motor. Turn the pointed fitting 90deg (see arrow).

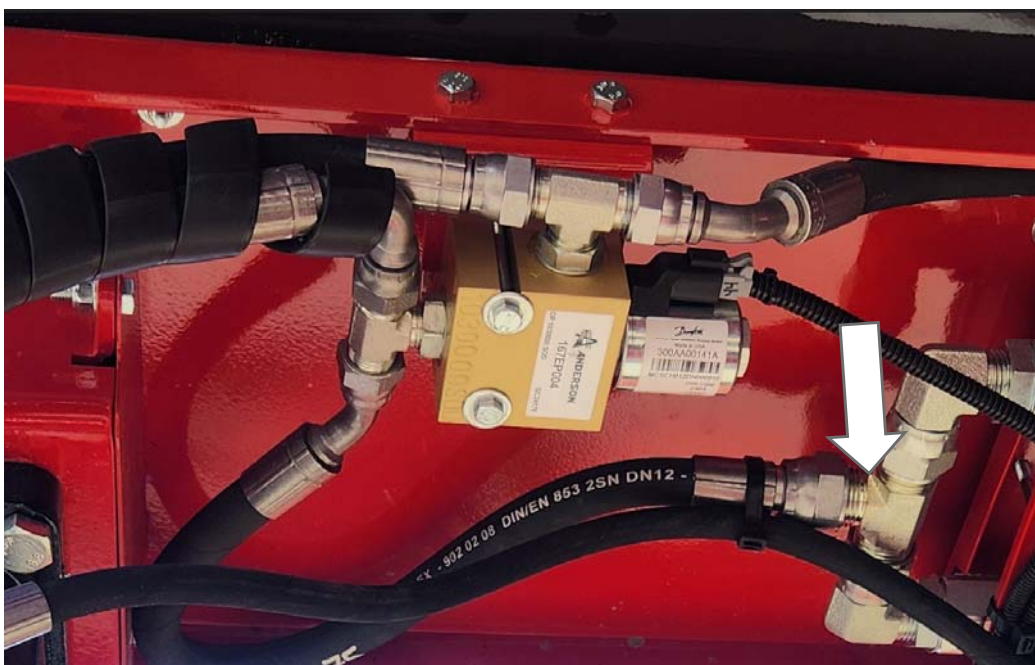

3- Install the hydraulic hose as shown in the following picture then put the hose protector on hoses 73 and 74.

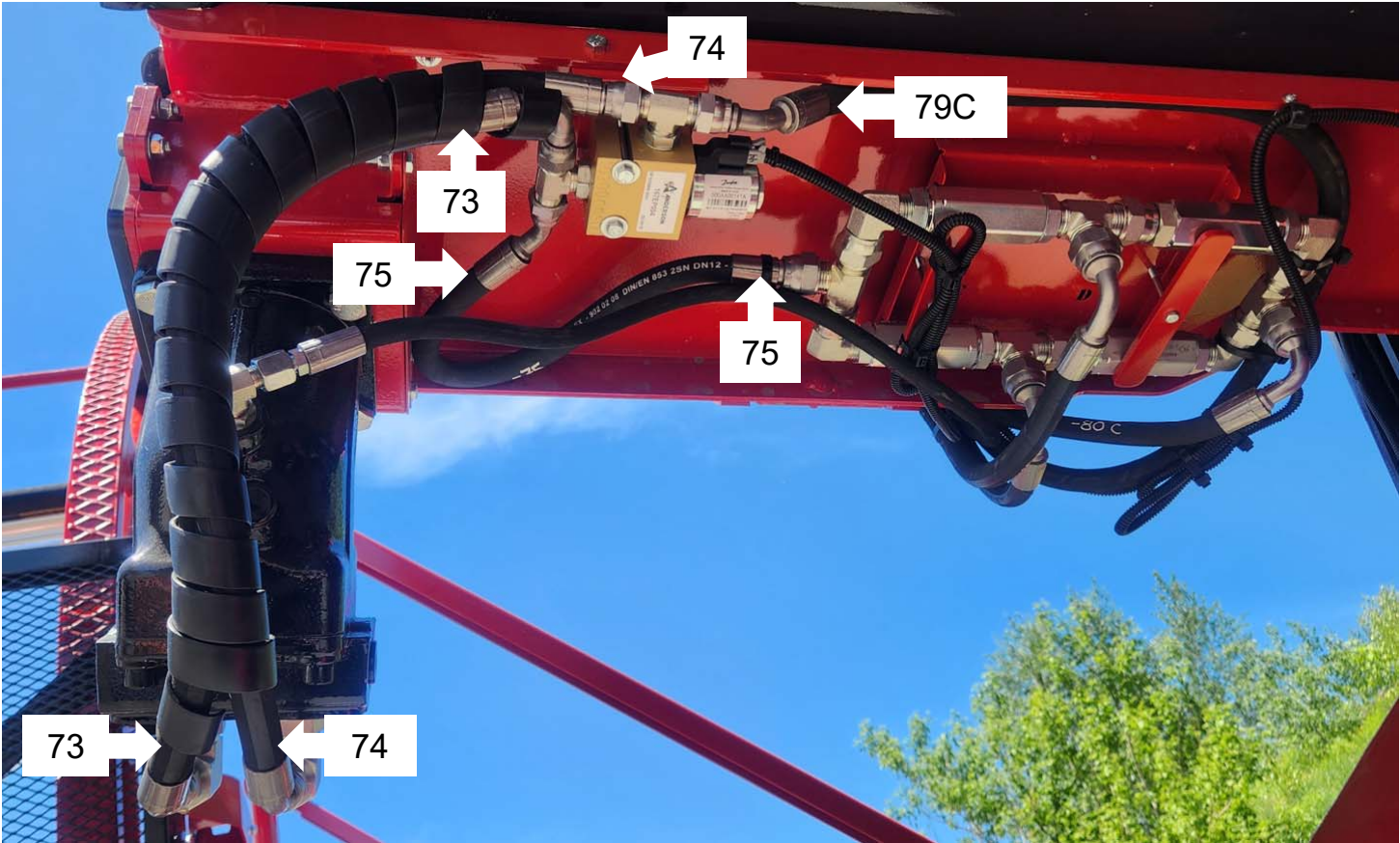



## Left side

1- Remove the hose protector on hose 37 and 81C. Disconnect hose 79C from conveyor motor. Remove hose 37 (no longer useful).



2- Bolt the valve to the conveyor frame near the conveyor motor.



3- Install the hydraulic hose as shown in the following picture then put the hose protector on hoses 73 and 74.

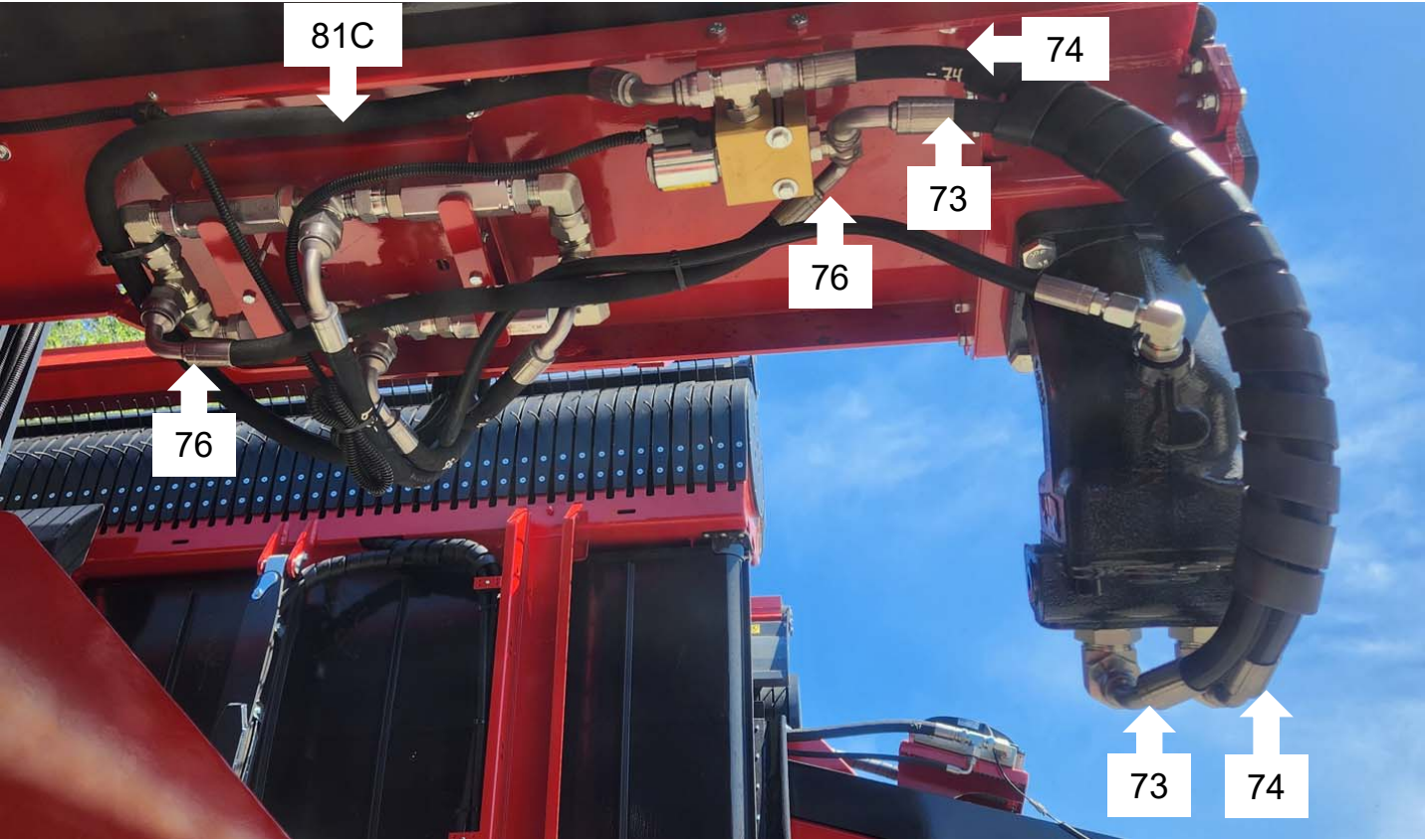



## Electrical wiring

1- Remove the guard located over the main valve.



2- Inside the frame, locate connector 38 to connect wire #315405.

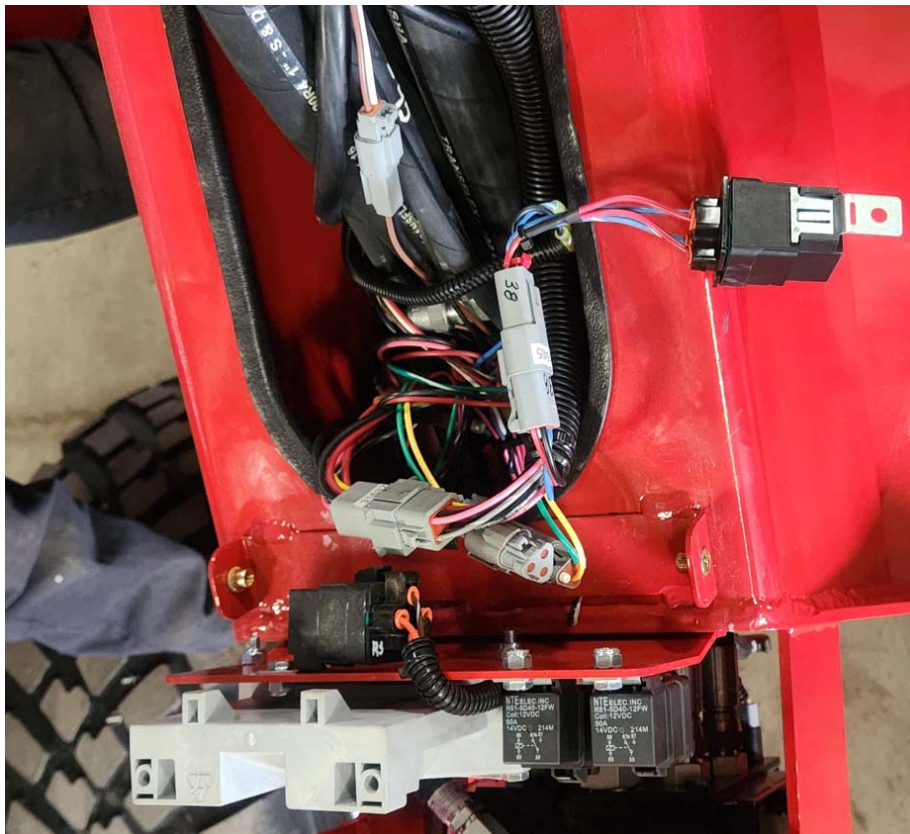

3- Insert wire 315405 inside the main frame using fish tape to follow the wires and hydraulic hoses already there. Make sure that connector 40 is on the left side and 39 is on the right side.

**Left side**

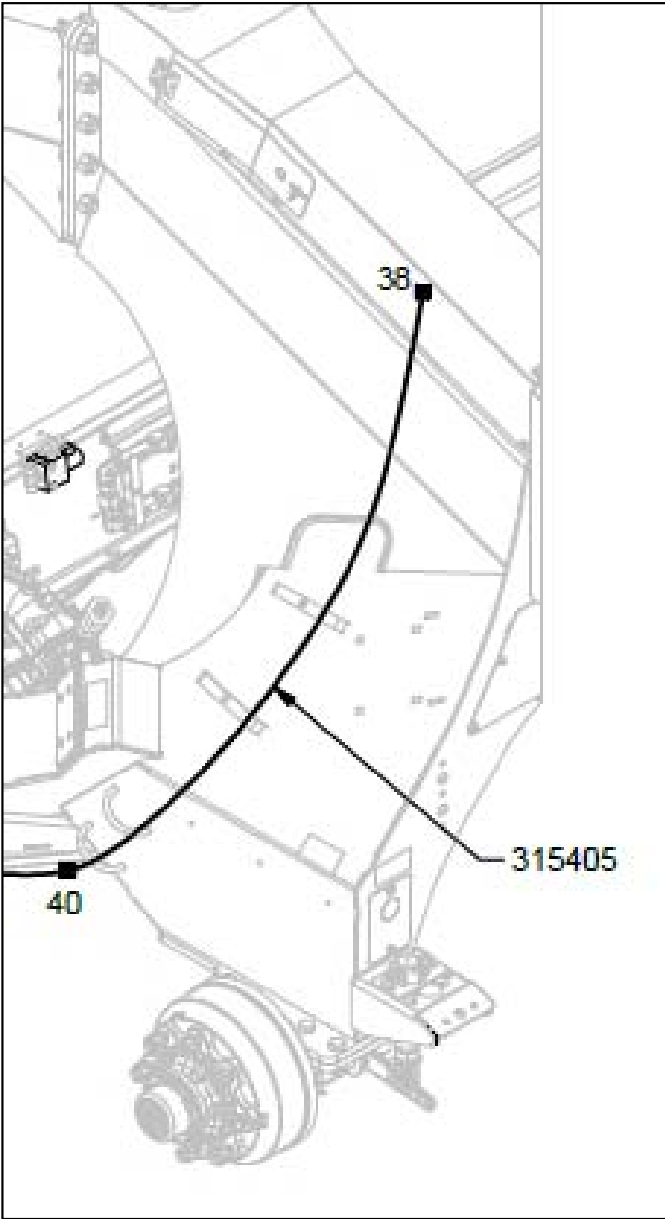

**Right side**

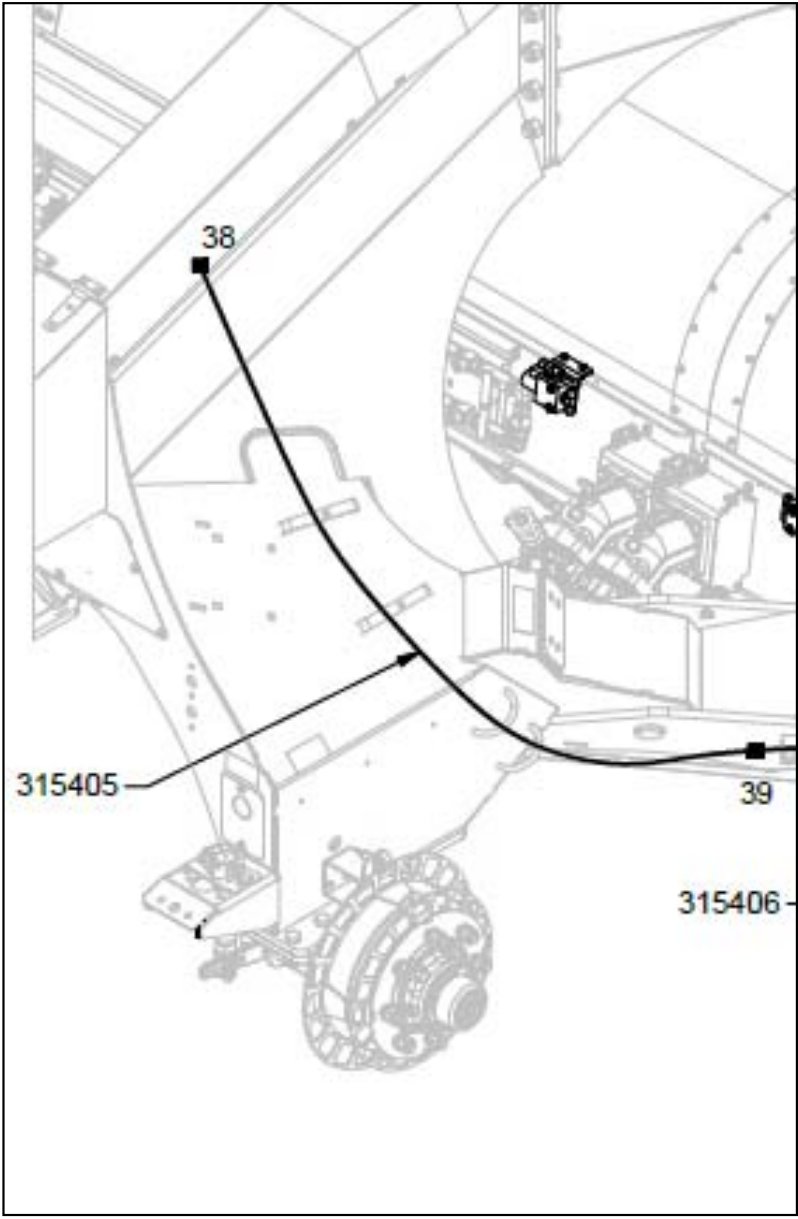

4- Verify the serial number of the machine to navigate the next steps.

5- Insert wire #315406 on right side following the wire of working lights.

**Picture of serial # 0 to 99**

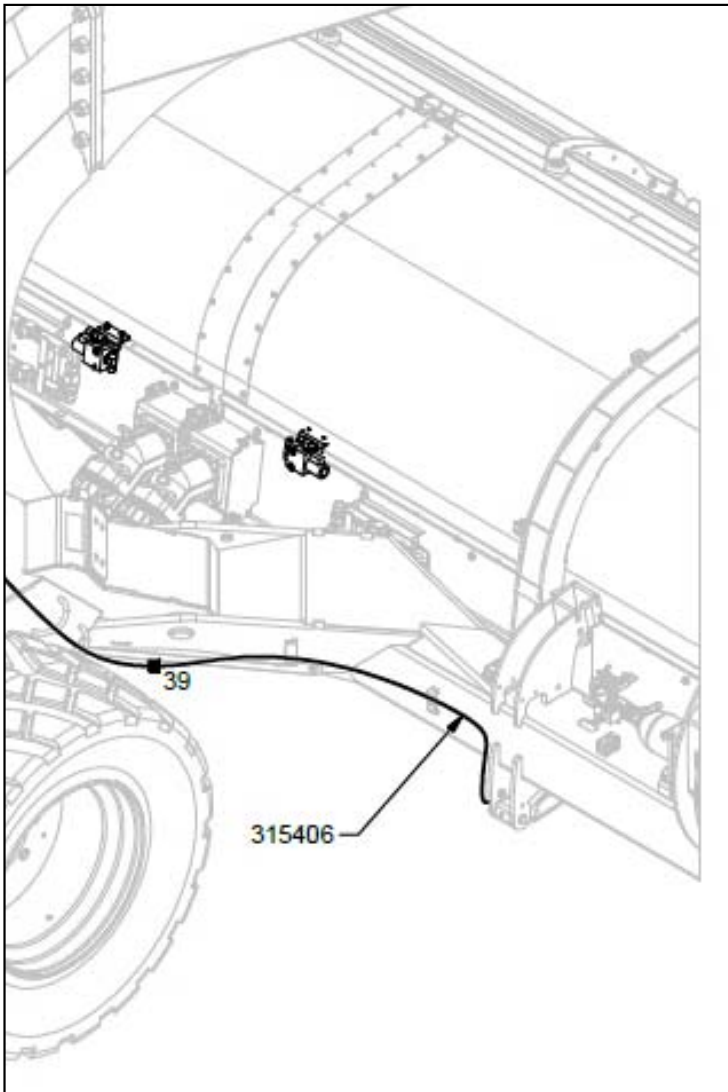

**Picture of serial #100 and more**

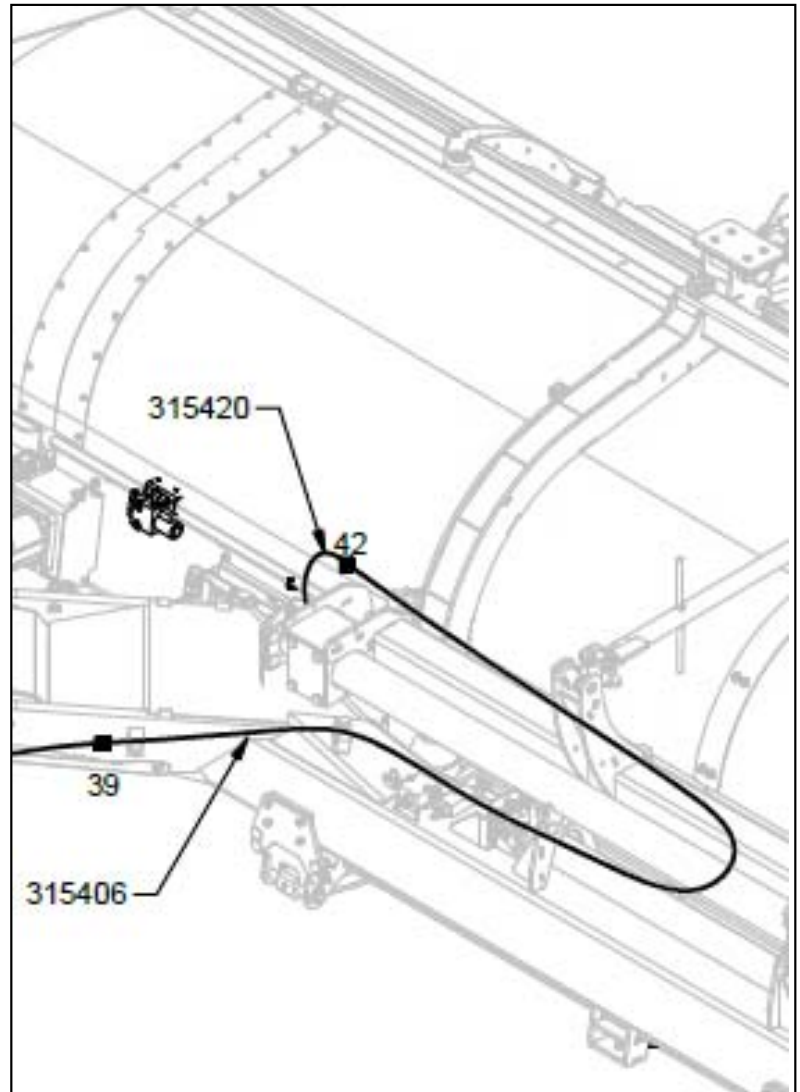

**6.1- This step is only for Mergepro of which serial number is between 0 and 99.**

Still on the right side, continue to follow the light wire and then plug connector 42 directly into the valve that was installed earlier.

Tie wire #315406 with the working light wire to ensure it is secure during machine movement.

**Picture of serial # 0 to 99**

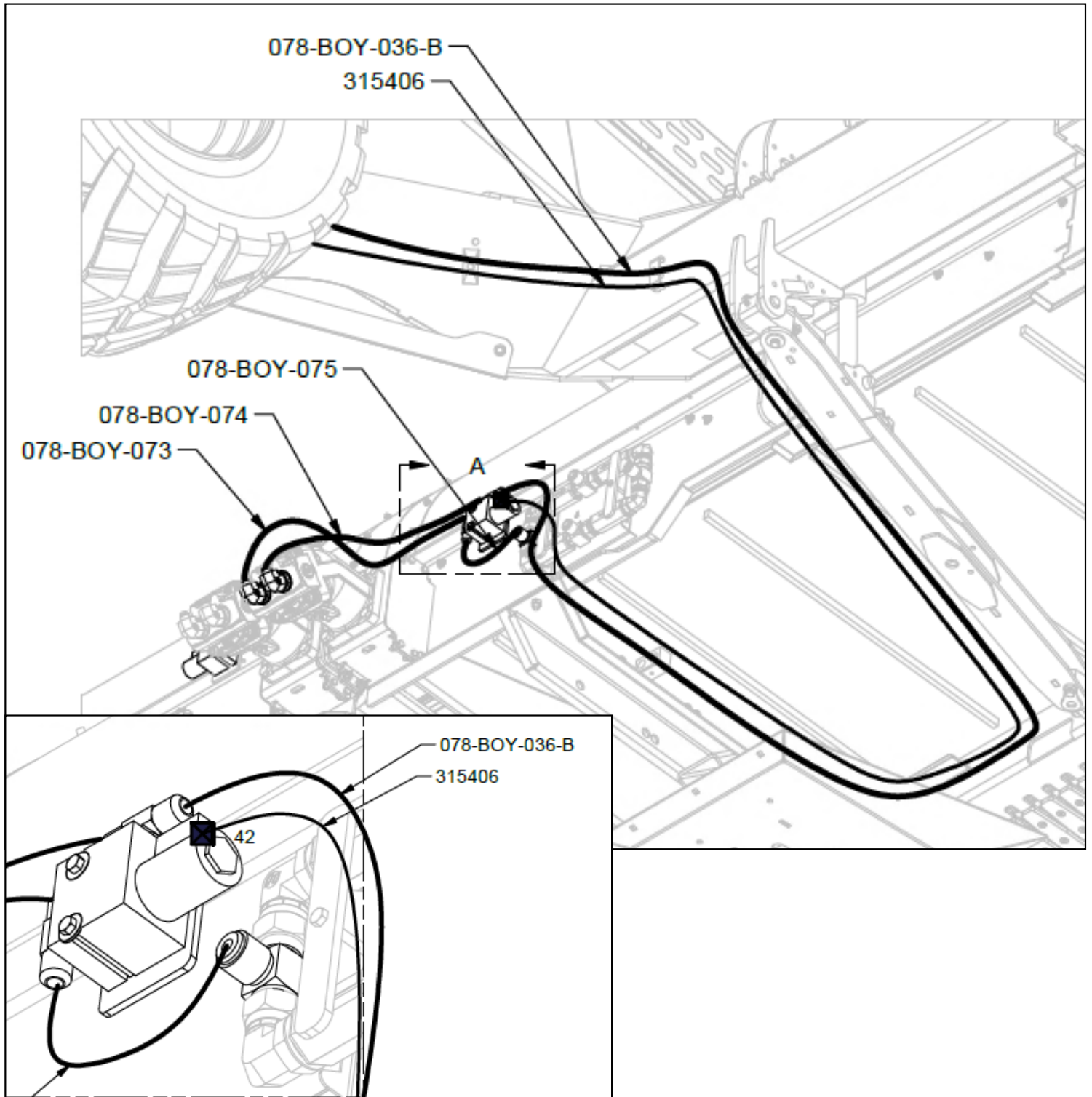



**6.2- This step is only for Mergepro of which serial number is 100 or more.**

Still on the right side, plug connector 42 and install wire 315420 following the light wire and then plug connector 44 directly into the valve that was installed earlier.

Tie wire #315406 and 315420 with the working light wire to ensure it is secure during machine movement.

**Serial #100 and more picture**

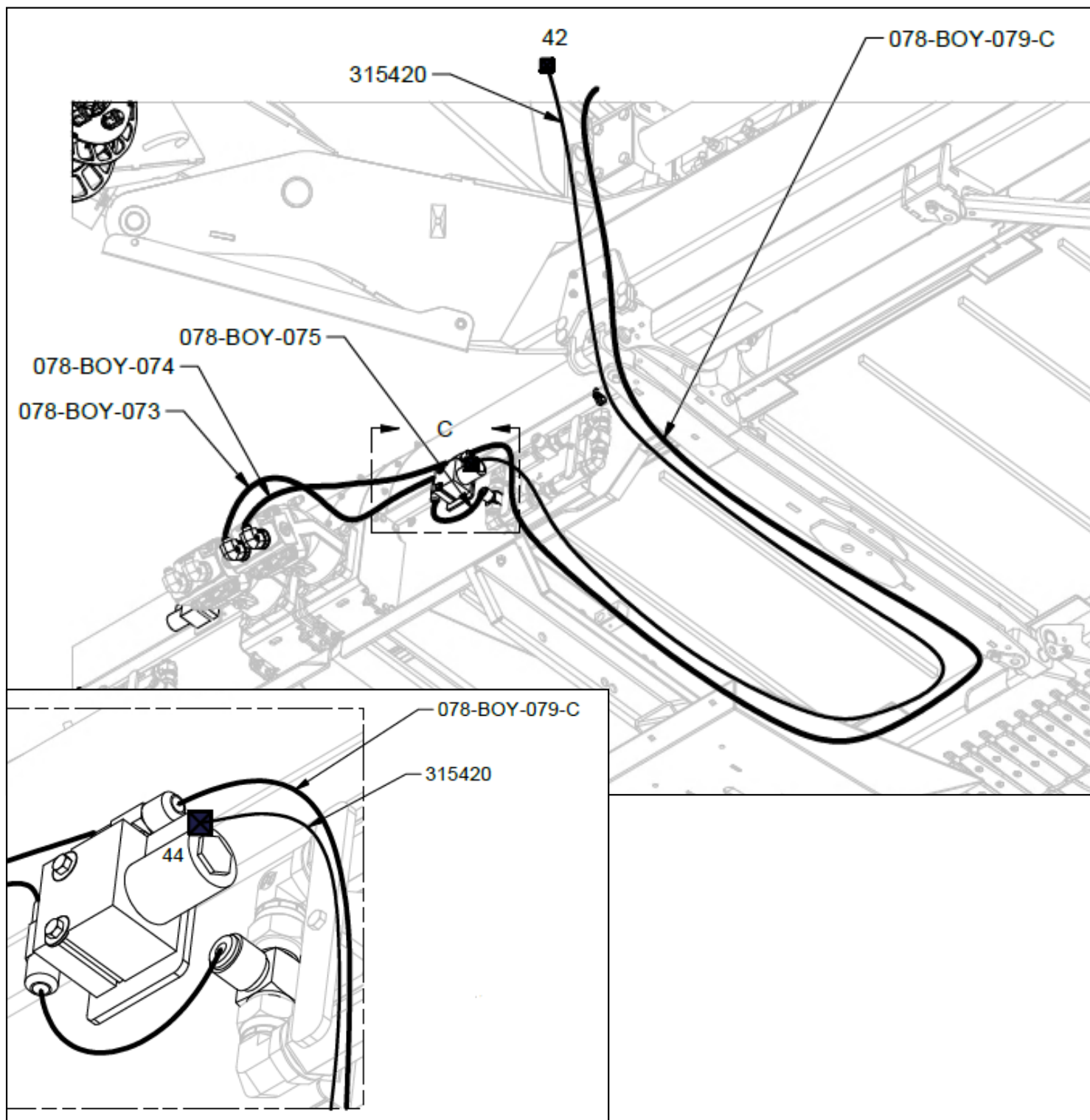

7- Install wire #315407 on left side following the working lights.

**Picture of serial # 0 to 99**

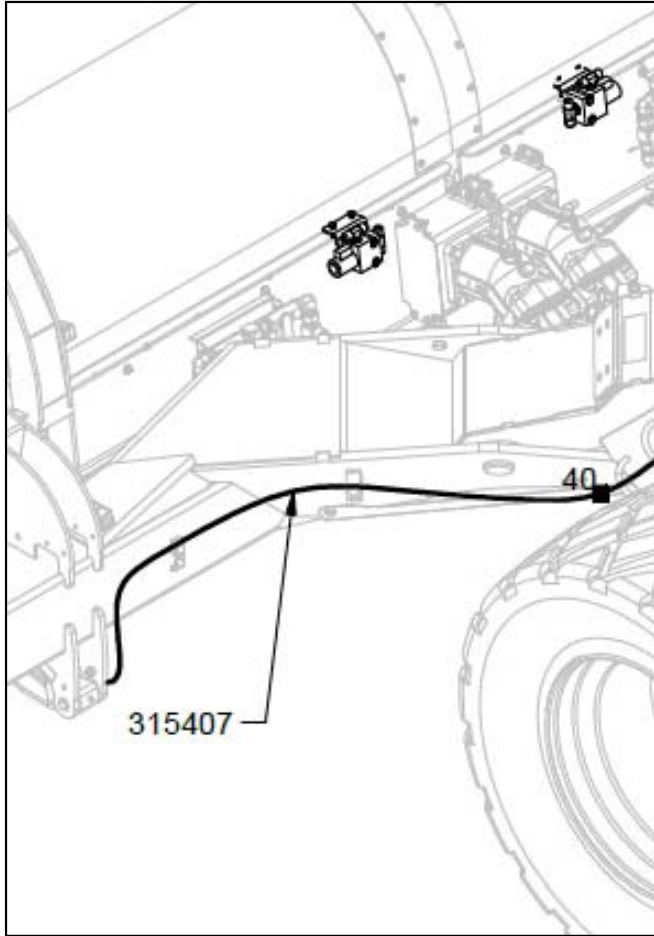

**Picture of serial #100 and more**

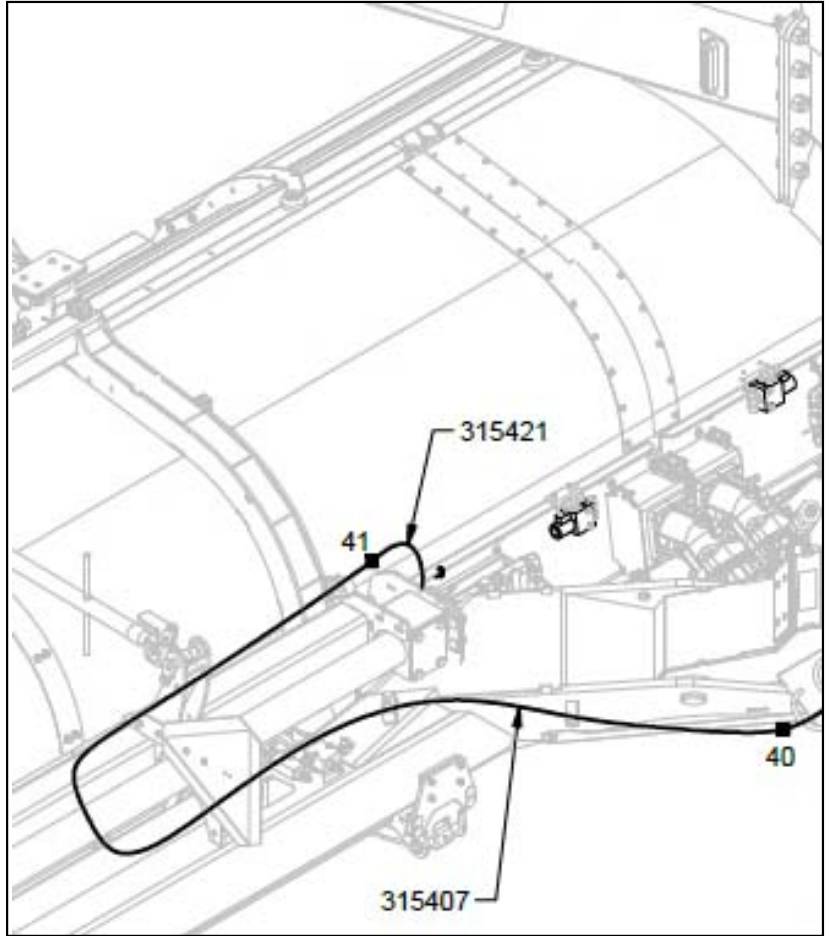

8.1- This step is only for Mergepro of which serial number is between 0 and 99.

Still on the left side, continue to follow the light wire and then plug connector 41 directly into the valve that was installed earlier.

Tie wire #315407 with the working light wire to ensure it is secure during machine movement.

**Picture of serial # 0 to 99**

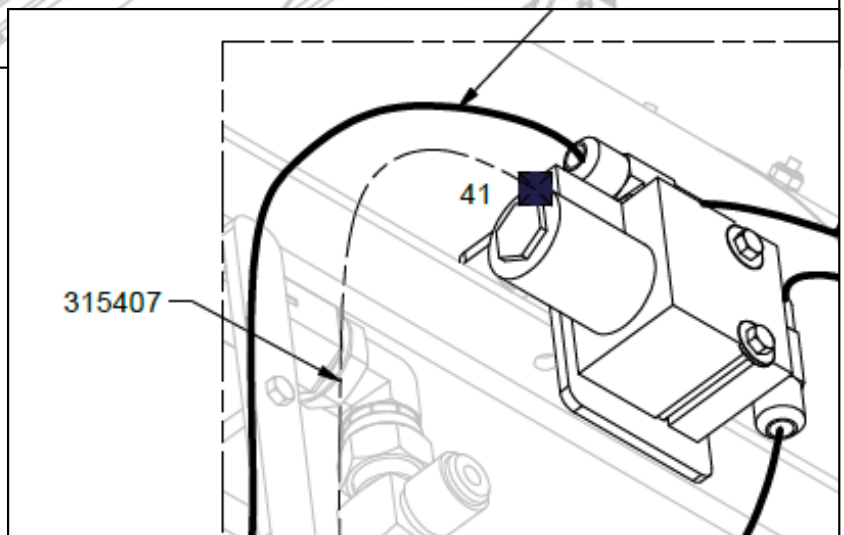
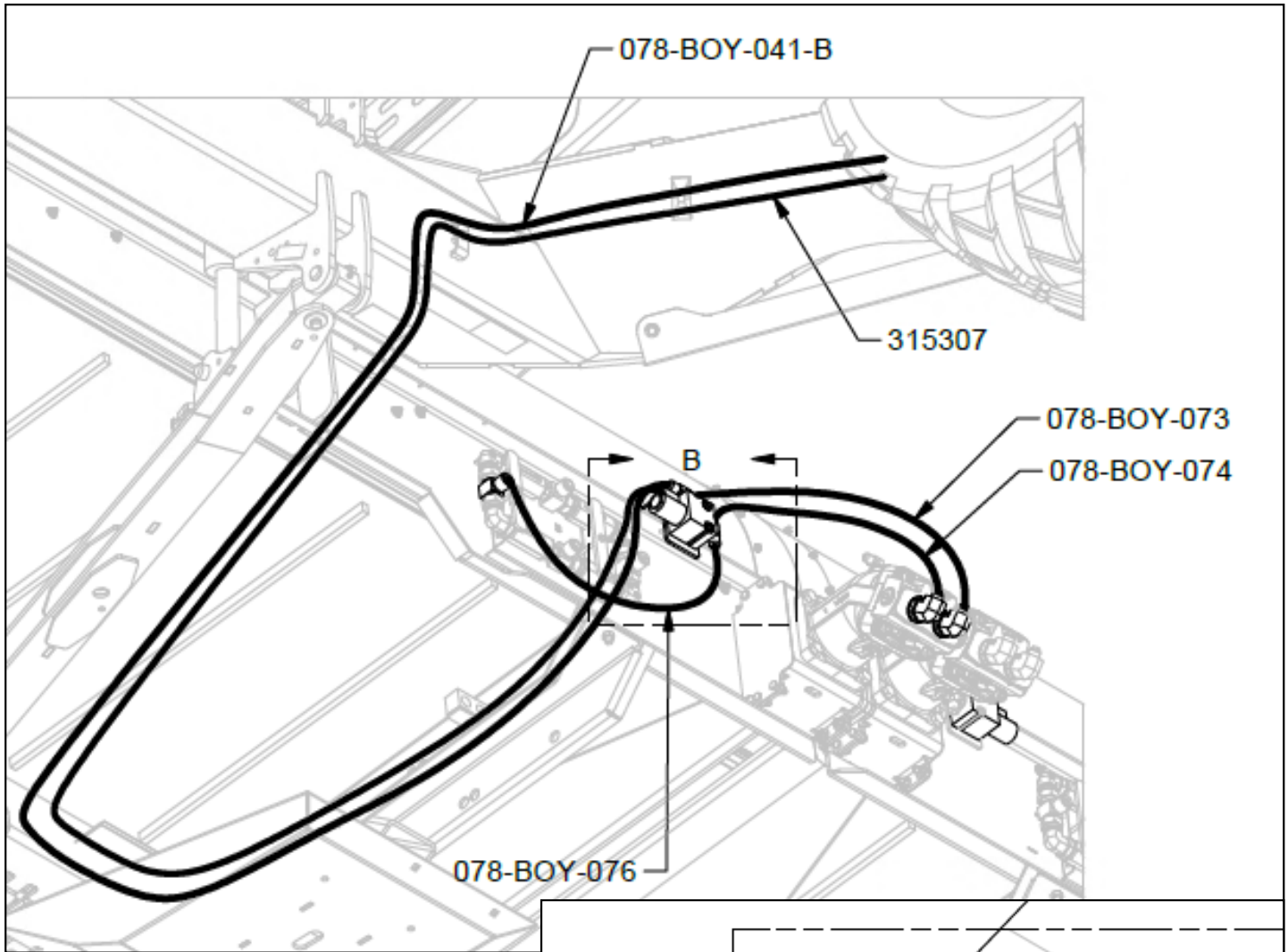



**8.2- This step is only for Mergepro of which serial number is 100 or more.**

Still on the left side, plug connector 41 and install wire 315421 following the light wire and then plug connector 43 directly into the valve that was installed earlier.

Tie wire #315407 and 315421 with the working light wire to ensure it is secure during machine movement.

**Picture of serial #100 and more**

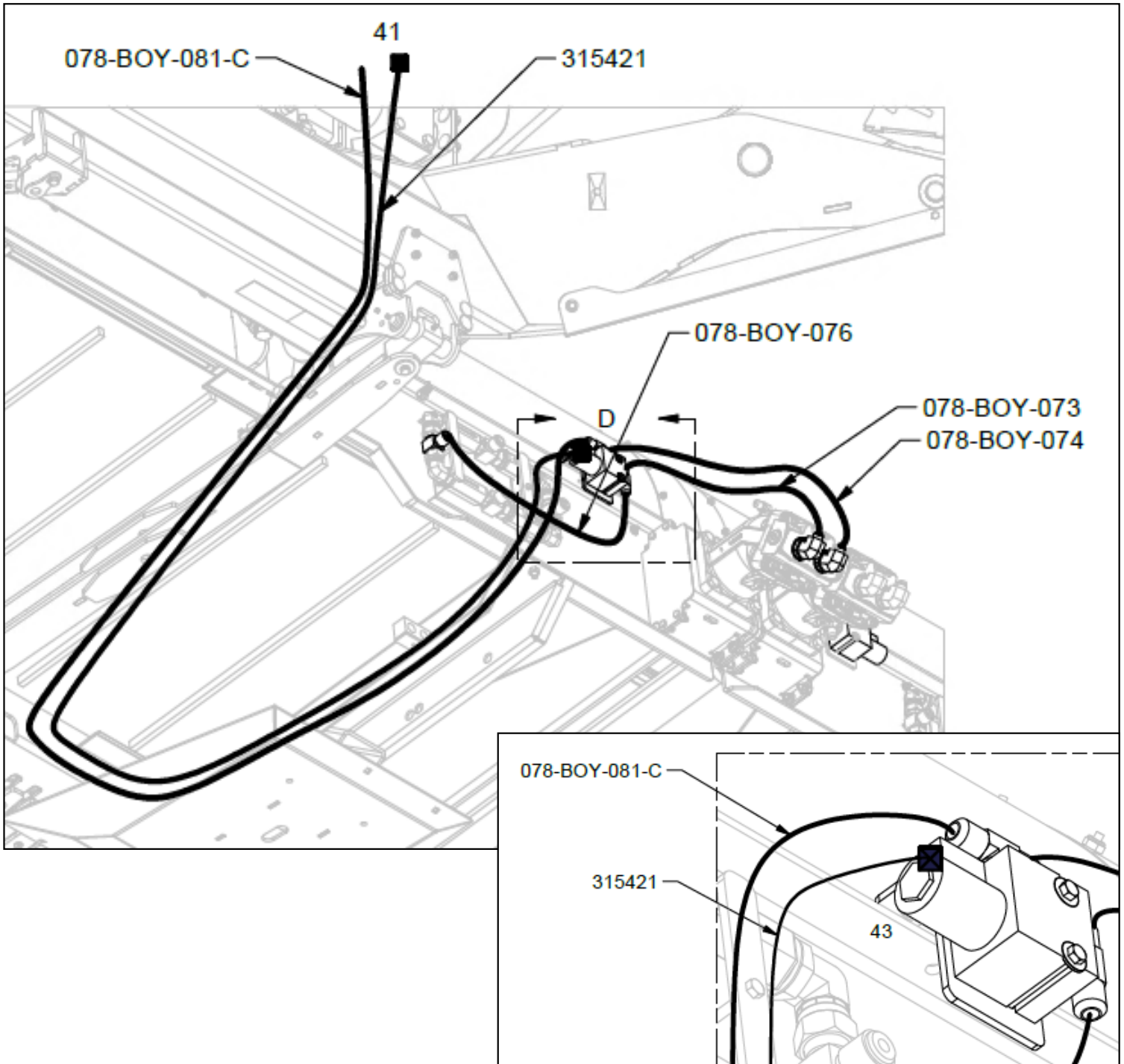

9.1- Use the Mergepro screen, go in menu, machine parameters. Change the state of "Conveyor stop function" to "ENABLED".

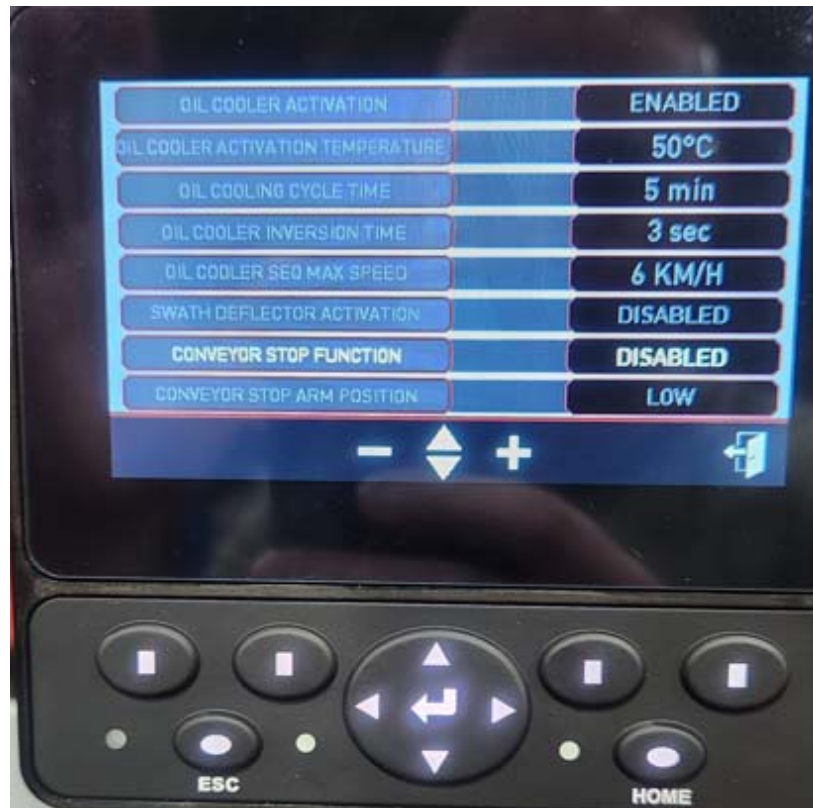

9.2- In the main screen, you now have access to the function by using "ESC" button.



10- Do a test run to ensure that everything works as expected. Then put the guard back on and make sure all wires are secure.