

Anderson MergePro hay merger
Quick startup guide.



ANDERSON

Just using a merger vs. a rake doesn't automatically improve crop quality.

Proper operation and maintenance are vital for producing better feed and trouble free operation. The following document goes over some operational guidelines to help ensure you are getting the most out of your Anderson merger.

We recommend leaving a lot of stubble Not only will this make the merger wear and perform better, but also the hay will dry better up off the ground, it promotes good regrowth, etc. 3" stubble height is recommended.

If possible, try not to drive on the hay It may leave streaks where you pushed the hay into the ground with the tire, and the pickup tine cannot reach it.

Do not run the tines into the ground!

The merger pickup does not need to touch the ground to pick up the crop. A big part of the reason to buy this machine is for the low ash/dirt and rock pickup, not to mention you can damage the heads in time. The primary causes of the merger contacting the ground are:

1. Stubble height
2. Seedbed preparation
3. Machine adjustment

1. Install the skid shoes
 - a. Unbolt bolts A (2 bolts per pair of skid shoes) (Figure 6).
 - b. Unbolt bolts B (2 bolts per pair of skid shoes) (Figure 6).

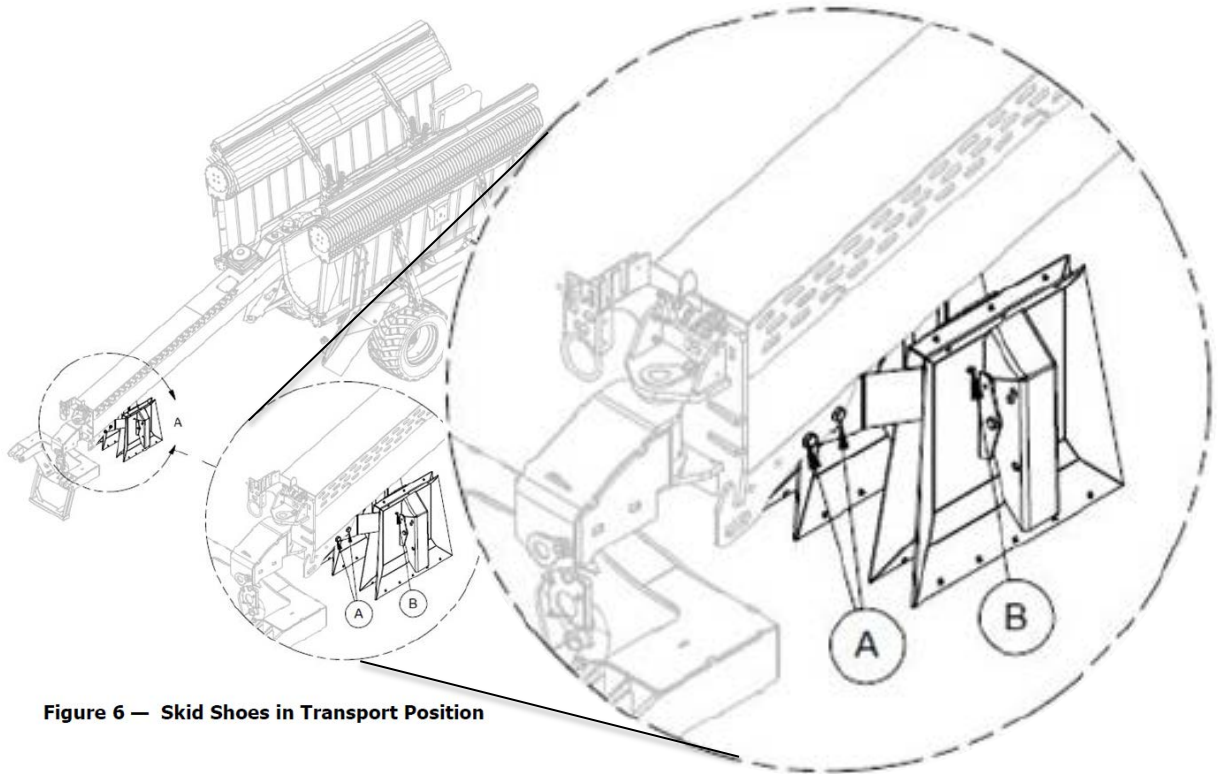
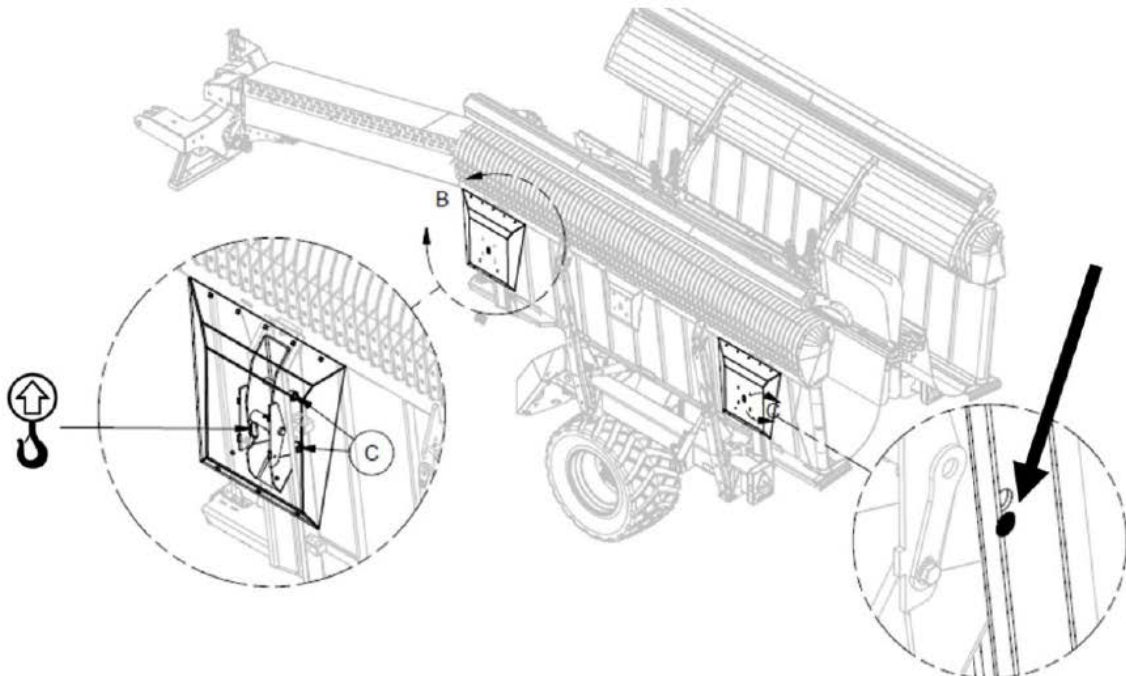

Figure 6 — Skid Shoes in Transport Position

- c. Install the skid shoes under the conveyors (2 skid shoes per conveyor) by securing them with bolts C (2 bolts per skid shoe) installed on the equipment.



2. Install the windguard in the proper positions.
 - a. Lower the conveyors to the ground, then extend them as far as possible from the center
 - b. Remove the straps that hold the windguard in place.
 - c. Remove bolts and nuts B (6 bolts and 6 nuts per conveyor) (Figure 8).
 - d. Remove bolts and nuts A (4 bolts and 4 nuts per conveyor), and remove the steel plates marked "TO BE REMOVED" (2 plates per conveyor) (Figure 8).
 - e. Remove bolts and nuts C (2 bolts and 2 nuts per conveyor) (Figure 8).

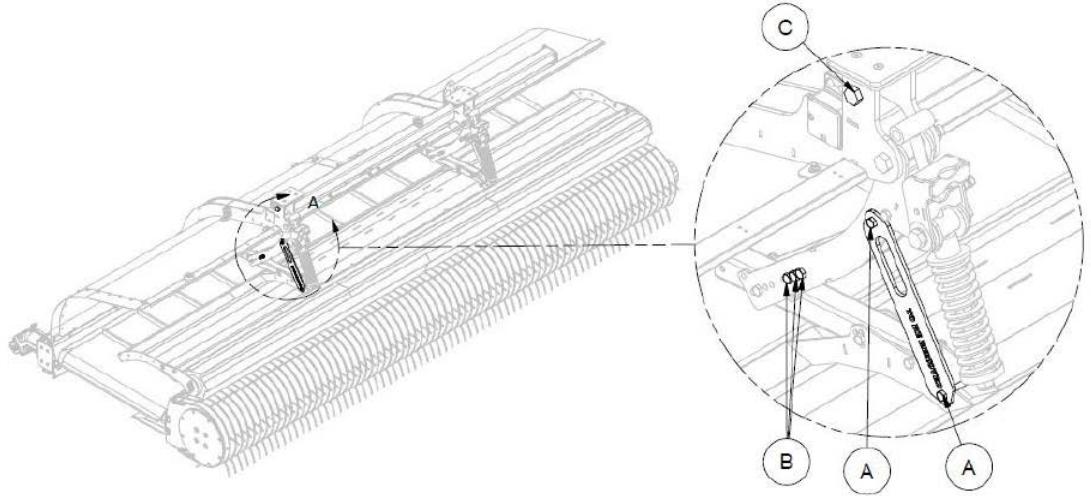
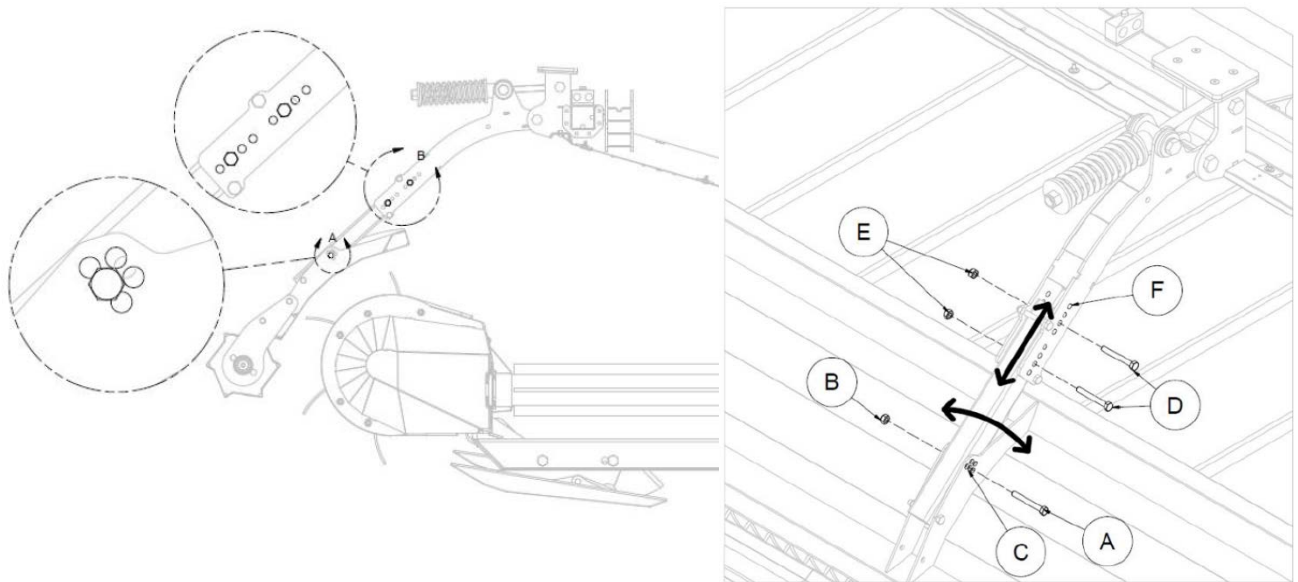

Figure 8 — Position of the "TO BE REMOVED" Plate

- f. Fold the windguard outward.
- g. Reinstall the bolts as shown in pictures below. Make sure to set them as illustrated.



3. Adjusting windguard – REALLY IMPORTANT

- a. Remove nut (A), washer (B), and the spring.
- b. Do the same for the other arm.
- c. Adjust nuts (D) to maintain a distance of 40 mm (1.5 in) between the windguard and the tines of the pickup where indicated on position (E) of the picture below.:
 - i. Loosen the nut to reduce the distance.
 - ii. Tighten the nut to increase the distance.
- d. Reinstall the spring (C), washer (B)
- e. Tighten the nut (A) until you get pass 2 inch (50mm) of the rod threads exposed towards the tractor.
- f. Do the same for the other arm.
- g. Repeat the procedure for the windguard on the other side of the machine.

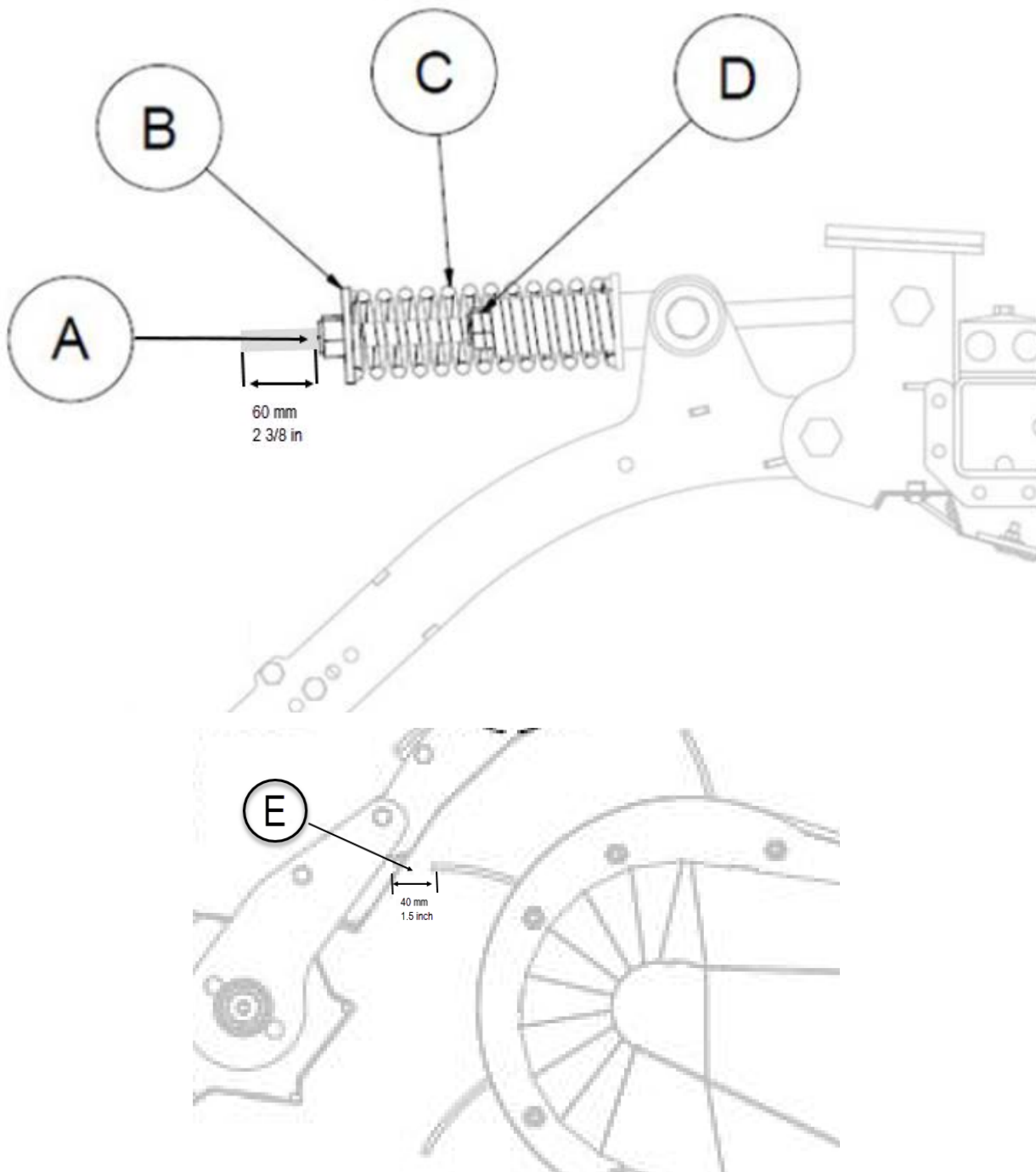

4. Inspect the “main hydraulic” suction hose between the pump and the oil tank and make sure the collar **is really tight**. You don’t want to spill oil on the ground during operation. If it happen, there is a “shut-off valve” on that suction hose to stop the oil from spilling to the ground.
5. Repositioned the MergePro wheels for proper tongue weight and road safety (Only for model 1060)
 - a. In order to be able to ship 2x 1060 model on a trailer, we have to move the wheel forward so they can fit on the trailer.
 - b. Upon reception, you must move them backward.
 - c. Not doing it could be fatal. The tongue weight will not be sufficient, therefore when pulling down the road at high speed you could lose tractor control.
6. Adjusting hitch height
 - a) Adjust the hitch height so the PTO is horizontal in order to reduce to eliminate the angle into the pto knuckle.
 - b) The pin cat 2-3 for the hydraulic lift arm shall be around 32 inch off the ground when PTO is horizontal. Most important, PTO shall be horizontal

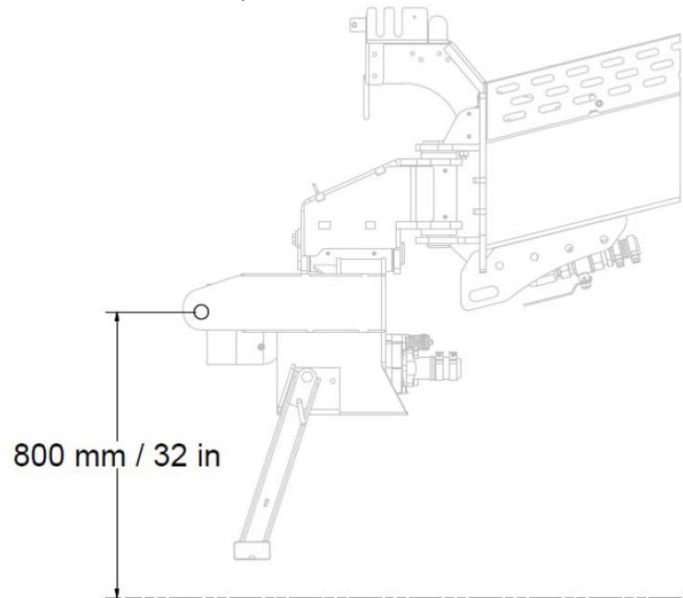

Figure 20 — Adjusting the Hitch

7. Adjusting teeth distance to the ground
 - a) Adjust top link so the teeth ends are no more than 1 inch below the crop stubble.
 1. Extend = will get the teeth close to the ground
 2. Shorter = further away from the ground
8. Adjusting the hydraulic float system
 - a) For each pickup unit, the hydraulic suspension pressure on the hydraulic gage located near the suspension hydraulic accumulator must be set at:
 1. MergePro915: 1000 psi once you have lowered the pickup unit on the ground AND hold the hydraulic for 2 more second (This will allow the pressure to come down to the relief valve pressure setting)

2. MergePro1060: 1275 psi once you have lowered the pickup unit on the ground AND hold the hydraulic for 2 more second (This will allow the pressure to come down to the relief valve pressure setting)
 - b) If the pressure is not correct, you can adjust it to reach the desire pressure. See operator manuals for instructions.
 - c) Float pressure is adjustable to adapt to varying ground conditions.
9. Set your PTO speed
 - a) Adjust it to 800rpm for 1000 pto
 - b) Adjust it at 540rpm for 540 pto
 - c) There is sensor that read your PTO speed, combine with the wheel speed sensor; it will insure that your pickup and belt are moving at proper speed to insure constant swath and effective collection of the crop.
10. Set your working mode
 - a) Manual
 1. Set the screen speed at the desire traveling speed
 - b) Automatic
 1. It will adjust itself accordingly to your ground travelling speed
11. Adjust your driving speed to match your land condition
 - a) Proper seedbed preparation to make the field as smooth as possible reduces the chance of running the merger into the ground.
 - b) This is important to note when running winter forage. Winter forage is often seeded into no till or minimum till situations, causing the field to be rough with high and low spots which increase the chance of running the machine into the ground and picking up foreign material (dirt, rocks).
 - c) In situations were the field conditions are rough, slowing down will reduce ground strikes, helping improve merger operation.

12. Make sure you have proper material projection from the pickup so the crop land on the belt evenly.

- a. Adjust the wind guard deflector above the pickup to allow the crop to fly over the belt and land on exiting traveling crop (IMPORTANT)
 - i. The distance between the tines tips and the inner side of the windguard deflector shall be about 1.5 inch.
- b. Adjust the GAIN on the monitor so the crop fly over the belt properly (IMPORTANT)
 - i. Long forage length – gain around 105-115%
 - ii. Medium forage length – gain around 125-135%
 - iii. Short forage length – gain around 140-150%
- c. Then after doing step A and B above, if the crop land in the “RED” zone, drive faster so the pickup could also turn faster and drop the crop where it should be for trouble-free journey.

