

QUICK START GUIDE

RB400



This Quick start up guide does not replace in any way or form the user manual of this unit. The intension of this document is for use when setting up the machine after delivery to the dealer and before the machine is transferred to the end user. This document should be used as a checklist and memory aid for employees already familiar with the guidelines in the user manual. Failure to operate the product correctly can result in damage to the product, personal property, and cause serious injury. This guide should not be transferred to the owner of the machine.



QUICK START GUIDE

RB400



After receiving your machine you will want to set it up to be ready for any demo opportunity or sale that may come along. Besides that, you want to be sure that the machine is in factory condition, free of damage from transport and defective parts due to the transport from our factory to your dealership. This is a quick guide that will help you to be up and ready in a short time. Before using the machine you must grease and oil all points on the wrapper that require it.

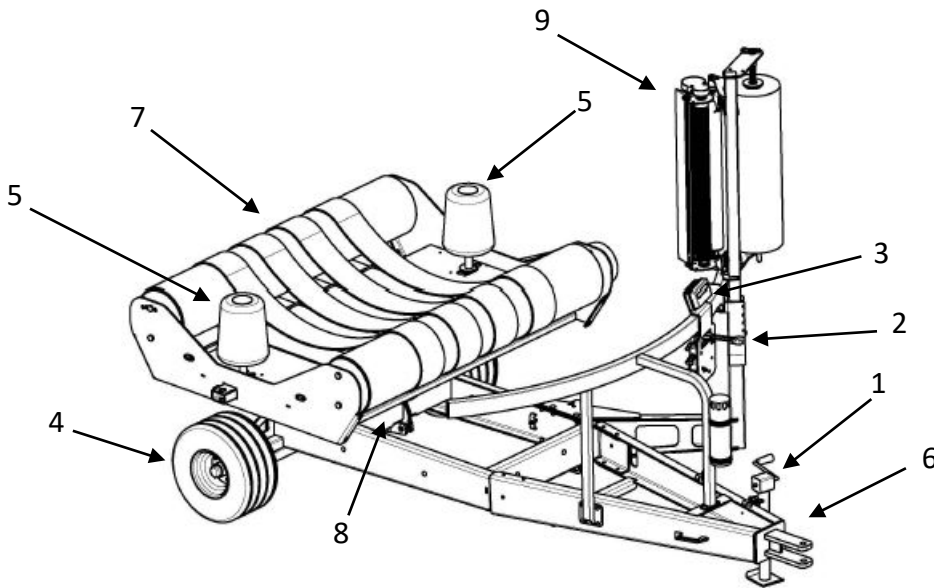

Standard Components	#
Jack with side crank	1
Manual controls	2
Bale and revolution counter	3
18.5 x 8.5 x 8 Tires	4
Support roller	5
Tongue	6
Turntable	7
Tilting table	8
Plastic film stretcher	9

Basics:

Round bale wrapper

- 4 or 5ft bale
- 1 stretcher (30'')
- Bale counter

Note: Before pressure washing the machine be sure to remove the computer (bale counter)

QUICK START GUIDE



RB400

When the machine is to be delivered to the user there are steps you must follow to be sure they are comfortable with wrapping their first bale. These steps are also important if you are doing a live demo. Setup is very important to bale size as this machine is not set to a specific bale at the factory.

- 1) Know your bale size before you start. Asking can help but an actual measurement of the bale is sometimes necessary.
- 2) Be sure that everything is greased (if left for more than 3 months outside without use the machine needs to be fully greased and oiled).
- 3) Your bale counter is charged and tested operational (see user manual on machine for functions).

The stretcher pole has 3 positions. Be sure that the position is not over the height of the bale or under it. (This part is normally removed for shipping so be sure to install it correctly to wrap your bales)

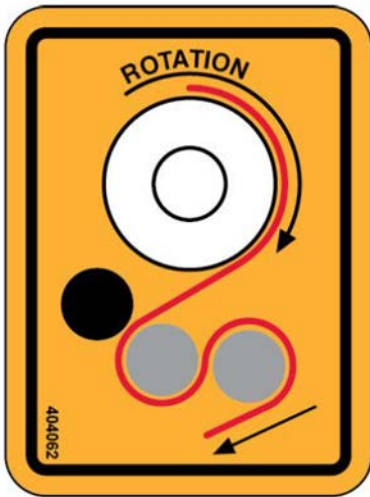

Put plastic in the stretcher. There is only one way to put the plastic through. See the diagram to the left. This is a sticker found on the machine as well.

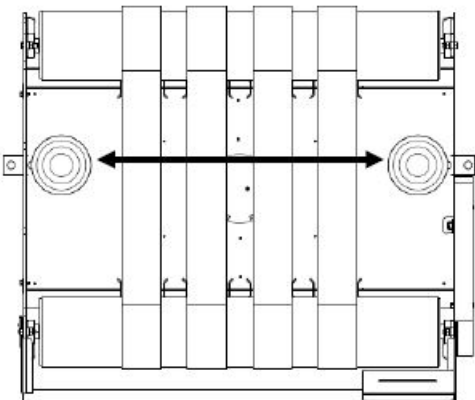

Set the cone rollers for 4 or 5 foot long bale.

QUICK START GUIDE

RB400



Hook the machine up to a tractor to test it.

Attach the machine's hoses to the tractor as shown. Be sure that your tractor is adjusted at a flow rate of 8 GPM at 2000 PSI.



Turn the bale counter ON and set it up.

- 1) Press the ON button
- 2) You will have to set the counter up. To do so you will hold the Adjust Select for 3 seconds. You can then scroll through 4 menus with the same button (adjust select)
- 3) Use the + and – to change the values of the menu.
- 4) When wrapping you will hear a buzzer from the counter on the last turn so that you know when to stop turning the table. The number will automatically reset once the sequence is finished.



Quick reference for correct plastic layers:

The way that we calculate the amount of plastic to apply on a bale is simple. You wrap the bale manually once with only one layer of plastic. You do not want to see any part of the bale when you are finished. You take the number of turns it took the table to do so and multiply it by 2 and then add one extra layer (or turn).

EX: 10 turns to completely cover the bale $\times 2 = 20$. plus one layer = 21. This is the number you want to program in your bale counter with.

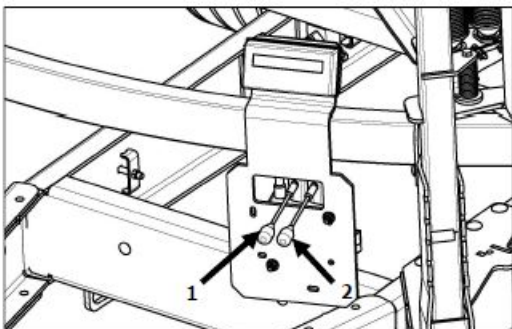

Once the bale counter is set up you can start wrapping with the manual lever.

- 1- Wrapping lever
- 2- Tilt the table